

**TECHNICAL MANUAL
OPERATOR'S, UNIT, DIRECT SUPPORT
AND GENERAL SUPPORT
MAINTENANCE MANUAL
FOR
TACTICAL WATER DISTRIBUTION
SYSTEM
MODEL TWDS20
NSN: 4320-01-361-9232**

HOW TO USE THIS MANUAL	iii
EQUIPMENT DESCRIPTION AND DATA	1-3
OPERATION UNDER USUAL CONDITIONS	2-23
OPERATOR TROUBLESHOOTING PROCEDURES	3-1
UNIT MAINTENANCE PROCEDURES	4-21
DIRECT SUPPORT MAINTENANCE PROCEDURES	5-1
MAINTENANCE ALLOCATION CHART*	B-1
COMPONENTS OF END ITEM AND BASIC ISSUE ITEMS LIST*	C-1
EXPENDABLE/DURABLE SUPPLIES AND MATERIALS LIST*	E-1

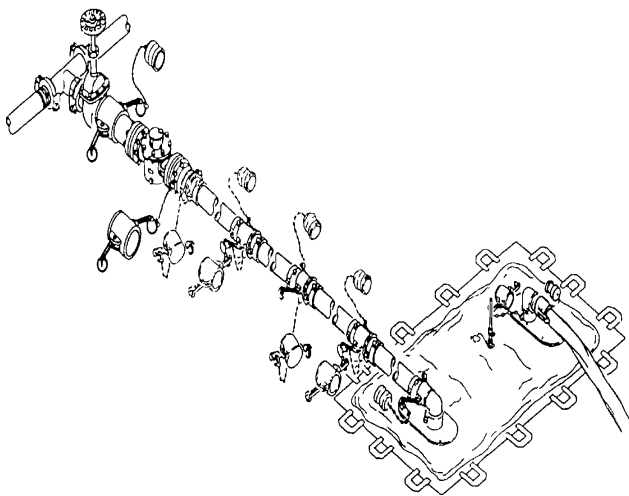
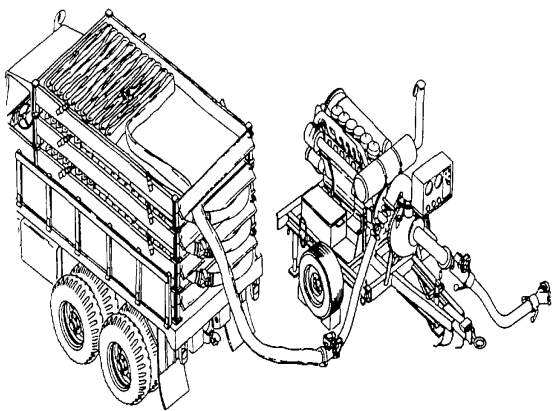

Distribution Statement A: Approved for public release; distribution is unlimited.

WARNINGS

HIGH PRESSURE

Do not open hose couplings when water system is under pressure. Hose end can whip, causing injury to personnel and damage to equipment.

CONTAMINATION HAZARD

To prevent contamination of drinking water, make sure all couplings are capped and plugged when components are not connected or not in use.

Keep dirt, mud, sand and debris from entering open couplings during assembly and disassembly.

Have water tested by medical personnel before dispensing to users.

HEAVY EQUIPMENT HAZARD

Lifting or moving heavy equipment incorrectly can cause serious injury. Do not try to lift or move more than 50 pounds by yourself. Get an assistant. Bend legs while lifting. Don't support heavy weight with your back.

Always use assistants during lifting operations. Use guide ropes to move hanging assemblies.

A lack of attention or being in an improper position during lifting operations can result in serious injury or death. Pay close attention to movements of assemblies being lifted. Do not stand under lifted assembly or in a position where you could be pinned against another object. Watch your footing.

Hoist used to lift water tanks from water tank chests must have minimum lifting capacity of 16,000 pounds.

FIRE HAZARD

To prevent injury to personnel and damage to equipment, do not over-fill fuel tanks on 125 and 600 gpm pumps. Make sure a fire extinguisher is nearby when refueling or operating the water pumps. Refer to the applicable technical manual for correct filling procedures.

FIRST AID

For artificial respiration, refer to FM21-11.

a /(b blank)

TECHNICAL MANUAL

NO: 10-4320-345-13

HEADQUARTERS
DEPARTMENT OF THE ARMY
WASHINGTON, D.C., 14 May 1993

**OPERATOR'S, UNIT, DIRECT SUPPORT
AND
GENERAL SUPPORT MAINTENANCE MANUAL
for
TACTICAL WATER DISTRIBUTION SYSTEM
MODEL TWDS20
NSN: 4320-01-361-9232**

REPORTING ERRORS AND RECOMMENDING IMPROVEMENTS

You can help improve this manual. If you find any mistakes, or if you know of a way to improve the procedures, please let us know. Mail your letter, DA Form 2028 (Recommended Changes to Publications and Blank Forms), or DA Form 2028-2 located in the back of this manual direct to Commander, U S Army Aviation and Troop Command, ATIN: AMSAT-I-MP. 4300 Goodfellow Blvd., St Louis, Mo 63120-1798

In either case, a reply will be furnished directly to you

Distribution Statement A Approved for public release, distribution is unlimited.

TABLE OF CONTENTS

	PAGE
HOW TO USE THIS MANUAL	iii
CHAPTER 1. INTRODUCTION	
Section I General Information.....	1-1
Section II Equipment Description and Data	1-3
Section III Principles of Operation	1-9
CHAPTER 2. OPERATING INSTRUCTIONS	
Section I Description and Use of Operator's Controls and Indicators.....	2-1
Section II Operator's Preventive Maintenance Checks and Services (PMCS).....	2-8
Section III Operation Under Usual Conditions.....	2-23
Section IV Operation Under Unusual Conditions.....	2-94
CHAPTER 3. OPERATOR MAINTENANCE INSTRUCTIONS	
Section I Lubrication Instructions.....	3-1
Section II Operator Troubleshooting	3-1
Section III Operator Maintenance Procedures	3-26
CHAPTER 4. UNIT MAINTENANCE INSTRUCTIONS	
Section I Repair Parts and Special Tools List	4-2
Section II Service Upon Receipt.....	4-2
Section III Unit Troubleshooting Procedures.....	4-4
Section IV Unit Maintenance Procedures.....	4-21
Section V Preparation for Storage or Shipment	4-78

TABLE OF CONTENTS - cont

		PAGE
CHAPTER 5.	DIRECT SUPPORT MAINTENANCE	
	Direct Support Maintenance Procedures	5-1
APPENDICES		
Appendix A	References.....	A-1
Appendix B	Maintenance Allocation Chart	B-1
Appendix C	Components of End Item and Basic Issue Items List	C-1
Appendix D	Additional Authorization List	D-1
Appendix E	Expendable/durable Supplies and Materials List.....	E-1
Appendix F	Lubricating Instructions	F-1
Appendix G	Illustrated List of Manufactured Items	G-1
Appendix H	Torque Limits	H-1
Appendix I	Mandatory Replacement Parts	I-1
Alphabetical Index	Index 1

HOWTO USIE THIS MANUAL

Be sure to read all Warnings before using your equipment

This manual contains operating and maintenance instructions for operation and maintenance of the Tactical Water Distribution System (TWDS)

- Chapter 1 Introduces you to the equipment and gives you information such as weight, height, length, generally used abbreviations and information on how the system works The chapter is preceded by a full page illustration of the equipment
- Chapter 2 Provides information necessary to identify and use the equipment's operating controls Operating instructions in this chapter tell you how to use the equipment in both usual and unusual weather conditions In addition, preventive maintenance instructions provide information needed to inspect and service the Tactical Water Distribution System
- Chapter 3 Provides operator troubleshooting procedures for identifying equipment malfunctions and maintenance instructions for performing operator maintenance tasks
- Chapter 4 Provides unit maintenance personnel with troubleshooting procedures for identifying equipment malfunctions and maintenance instructions for repairing defective equipment
- Chapter 5 Provides direct support maintenance personnel with maintenance instructions for performing repairs on equipment as authorized by the maintenance allocation chart
- Appendix A Provides a list of frequently used forms and publications referenced or used in this manual.
- Appendix B The Maintenance allocation chart identifies repairable components and the maintenance level authorized to perform the repairs.
- Appendix C Lists components that are not mounted on the equipment, but are required to make the unit functional All components in the Components of End Item and Basic Issue Items Lists are illustrated for easy identification.
- Appendix D Lists additional equipment authorized for your unit for use with the water system, but are not supplied as part of system This equipment list may include fire extinguishers, buckets, protective clothing etc.
- Appendix E Provides you with information about expendable supplies such as sealants, lubricants, chemicals etc that are used when operating or maintaining the equipment.
- Appendix F Contains lubrication instructions that are required to keep the equipment in good working condition.

HOWTO USE THIS MANUAL cont.

- Appendix G Provides a list of items and instructions on how to make certain tools and devices required to perform some of the maintenance tasks contained in this manual.
- Appendix II Provides a table of torque values for various sizes of nuts and bolts.
- Appendix I Lists parts that must be replaced when performing maintenance on components of the water system This list includes such things as gaskets, lock washers and seals.

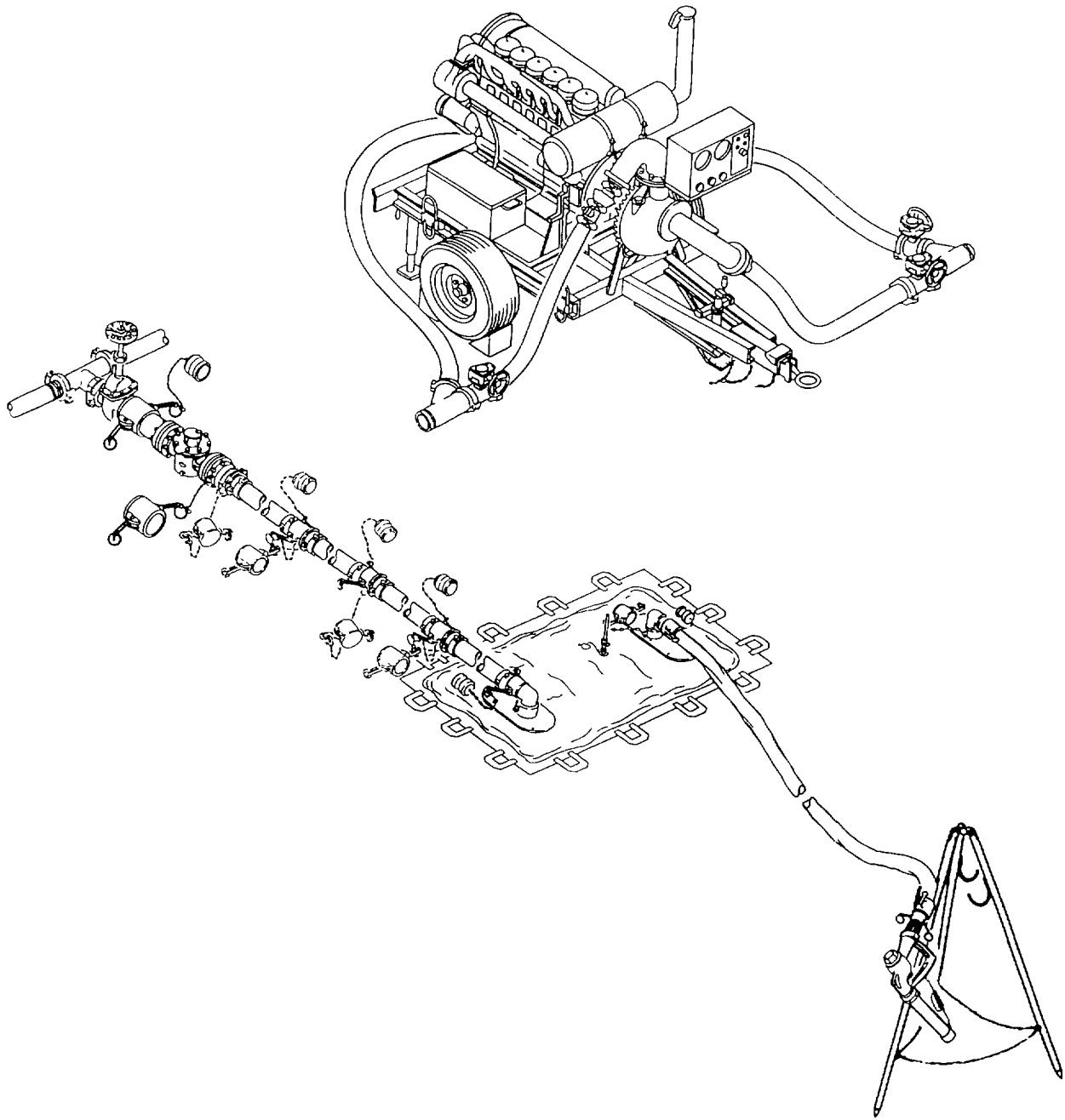

CHAPTER 1

INTRODUCTION

Paragraph	Page
Section 1 General Information	1-1
1-1. Scope	1-1
1-2. Maintenance Forms Records and Reports	1-1
1-3. Corrosion Prevention and Control (CPC)	1-1
1-4. Destruction of Army Materiel to Prevent Enemy USC	1-2
1-5. Reporting of Equipment Improvement RECOMMENDATIONS (EIR)	1-2
1-6. Nomenclature Cross Reference List.....	1-2
1-7. List of Abbreviations	1-2
1-8. Glossary	1-2
Section II. Equipment Description and Data	1-3
1-9. Equipment Characteristics and Features	1-3
1-10. Location and Description of Major Components	1-4
1-11. Equipment Data	1-8
Section III. Principles of Operation	1-9
1-12. System Technical Principles of Operation	1-9

Section I. GENERAL INFORMATION

1-1. SCOPE.

This manual contains Operating instructions and Unit Direct Support and General Support maintenance instructions required to operate and maintain the Tactical Water Distribution System (TWDS) 10-mile Segment Model TWDS20. The TWDS provides distribution of potable water to a 300K and/or 800K water storage and distribution system or another TWDS system. The TWDS is intended for potable water use only and should not be operated using contaminated or brackish water.

1-2. MAINTENANCE FORMS, RECORDS, AND REPORTS.

Department of the Army forms and procedures used for equipment maintenance will be those prescribed by DA Pam 738-750 (The Army Maintenance Management System (TAMMS)).

1-3. CORROSION PREVENTION AND CONTROL.

- a. Corrosion Prevention and Control (CPC) of Army Materiel is a continuing concern. It is important that any corrosion problems with this item be reported so that the problem can be corrected and improvements can be made to prevent the problem in future items.

1-3. CORROSION PREVENTION AND CONTROL - cont.

- b. While corrosion is typically associated with rusting of metals, it can also include deterioration of other materials, such as rubber and plastic. Unusual cracking, softening, swelling or breaking of the materials may be a corrosion problem.
- c. If a corrosion problem is identified, it can be reported using Standard Form 368, Product Quality Deficiency Report Using key words such as "rust", "deterioration", or "cracking" will insure that the information is identified as a CPC problem. The form should be submitted to the address specified in DA Pam 738-750.

1-4. DESTRUCTION OF ARMY MATERIEL TO PREVENT ENEMY USE.

Methods and procedures for destruction of Army materiel to prevent enemy use are covered in TM 750-244-3.

1-5. REPORTING EQUIPMENT IMPROVEMENT RECOMMENDATIONS (EIRs).

If your TWDS needs improvement, let us know. Send us an EIR. You, the user, are the only one who can tell us what you don't like about your equipment. Let us know why you don't like the design or performance. Put it on an SF 368 (Quality Deficiency Report) Mail it to us at Commander, U S Army Aviation and Troop Command, ATTN AMSAT-I-MD/O, 4300 Goodfellow Boulevard, St Louis, MO 63120-1798. We'll send you a reply.

1-6. NOMENCLATURE CROSS REFERENCE LIST.

Common Name	Official Nomenclature
Water Tank	20,000 Gallon Collapsible Fabric Tank

1-7. LIST OF ABBREVIATIONS. |

Abbreviation	Nomenclature
K	Kilo (Thousand)
°F	Degrees Fahrenheit
TWDS	Tactical Water Distribution System
Gpm	Gallons Per Minute
300K WSDS	300,000 Gallon Water Storage and Distribution System
800K WSDS	800,000 Gallon Water Storage and Distribution System
TRICON	Triple Container

1-8. GLOSSARY.

Term	Description
Hypochlorination	Purification of water by combining water with a solution made from calcium hypochlorite powder

Section II. EQUIPMENT DESCRIPTION AND DATA**1-9. EQUIPMENT CHARACTERISTICS, CAPABILITIES FEATURES.**a Characteristics

- (1) Self contained.
- (2) Easily transportable Sixty-four flaking boxes store over ten miles of collapsible 6-inch discharge hose
- (3) Reusable triple containers provide storage for loose components
- (4) Quick disconnect couplings on distribution system hoses allow rapid setup and take down
- (5) Boltless couplings reduce hoseline assembly time
- (6) Adaptable to meet varying mission and site requirements
- (7) No external electrical power source required

b Capabilities and Features

- (1) Two storage and distribution points provide a storage capacity of 40,000 gallons Water may be tapped from the main line, stored, treated and dispensed through hand operated distribution nozzles.
- (2) Capable of transporting water at 600 gpm across level terrain
- (3) Can transport approximately 700,000 gallons of water in a 20-hour period
- (4) Can be setup and ready for operation in about 48 hours

1-10. LOCATION AND DESCRIPTION OF MAJOR COMPONENTS

- a Flaking Box Assembly Refer to figure 1-1 Sixty-four flaking boxes are supplied with the TWDS Flaking boxes aid setup and recovery of the TWDS hose line
 - (1) Flaking Box Used to store and lay discharge hoses. Hoses are flaked into the box for storage and pulled from the box during hose line setup. Removable panels aid repacking. Boxes can be stacked to reduce storage space.
 - (2) Discharge Hose The TWDS hose line is made up of 128 6-inch discharge hoses that carry water throughout the system. Each hose is 500 feet long and has a single grooved coupling installed on both ends. Hoses are joined using coupling clamps.
- b Swivel Swivels are installed in the hose line at 1000 foot intervals to prevent damage to the hoses caused by twisting and expansion.
- c Coupling Clamps Boltless coupling clamps are used to join all grooved 6-inch hoses and components. Clamps are hinged and are supplied with a tool required for installation.
- d Sling Assembly The lifting sling is supplied for lifting and movement of the flaking boxes. A stack of four flaking boxes may be lifted at one time.
- e Road Crossing Guards Installed over hose line passing under roadways. Prevents damage to hose caused by passing vehicles and equipment. Guards are installed where required.
- f Suspension Kit Used to suspend hose line across streams, gullies or rough terrain.
- g Displacement and Evacuation Kit. Used to remove water and air from hoses before repacking.
- h Pressure Regulating Valve The skid mounted valve reduces system pressure to protect hoses and components. Valve is installed in the hose line where pressures are expected to exceed 225 psi. Three manually operated isolation valves allow maintenance of the pressure regulating valve while installed in the hose line.
- i Pumping Stations Each pumping station contains a 600 gpm pump and the required hoses, valves and tees to connect the pump to the water system. Six pump stations are supplied with the TWDS. Five stations are used during normal operation, while a sixth pump station is kept off line as a spare. The sixth station may be used to increase system capacity when operating in hilly terrain. Pump stations are installed in the hose line at two mile intervals.
 - (1) 600 Gpm Pumps The 600 gpm pumps are the primary source of water delivery. The pumps are self contained, engine driven, trailer mounted and fitted with suction and discharge elbows for connecting the hose line. Each pump draws water and feeds it to the next downline pump or distribution point. Refer to the applicable TM for location and description of major components on the 600 gpm pump.
 - (2) Check Valve In-line check valve prevents back flow of water through the 600 gpm pumps when the pumps are shutdown.

1-10. LOCATION AND DESCRIPTION OF MAJOR COMPONENTS - cont

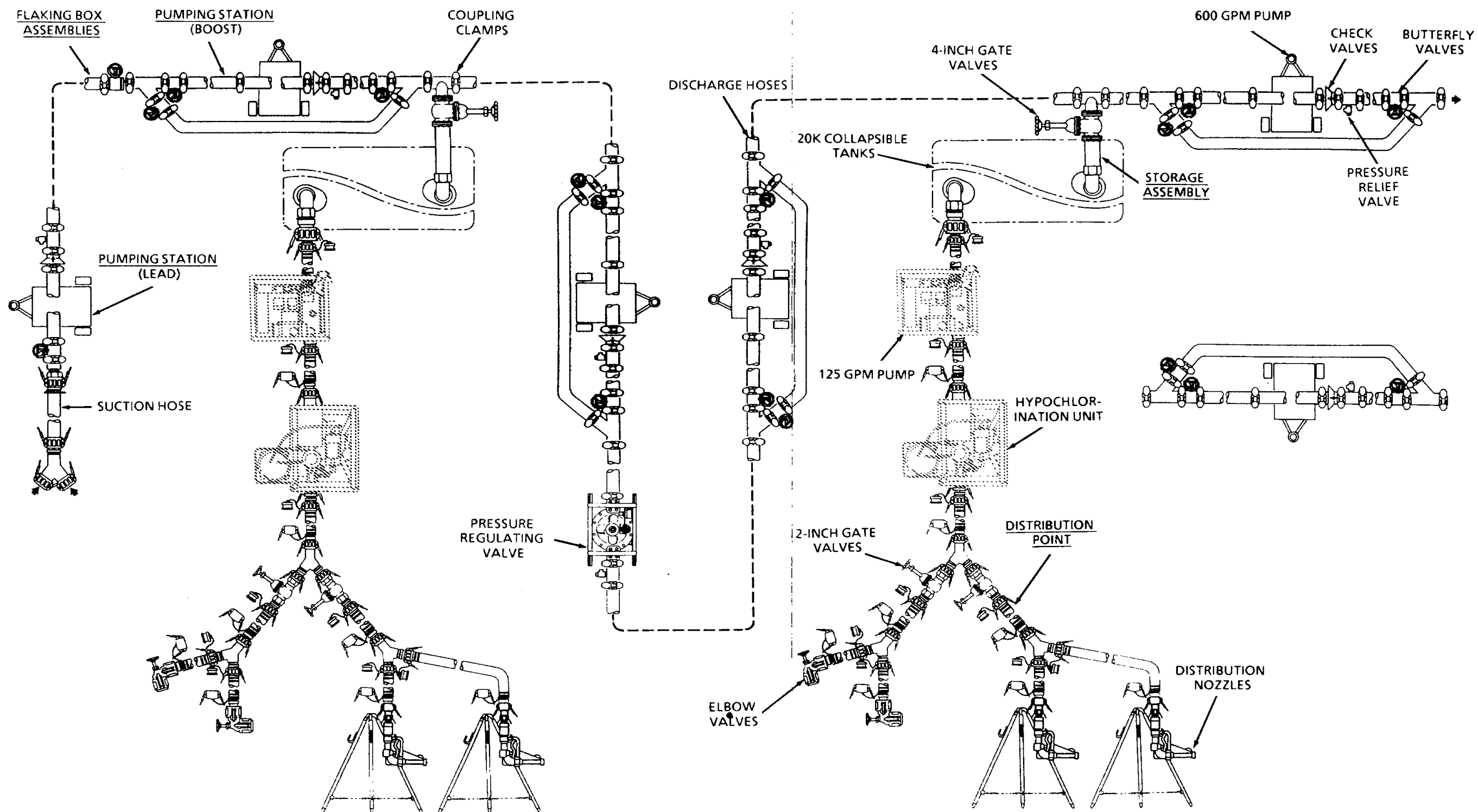

Figure 1-1. Tactical Water Distribution system

1-10. LOCATION AND DESCRIPTION OF MAJOR COMPONENTS - cont.

- (3) Pressure Relief. Valve Relieves excessive water pressure from pumping station. Pressure relief valve opens when water pressure exceeds 200 psi.
 - (4) Discharge Hose. 6-inch collapsible hose distributes water through pumping station.
 - (5) Butterfly Valves. Hand operated valves control water flow through pump station. Valves can be used to isolate pump from hose line during pump maintenance or replacement.
- j Suction Hose. 6-inch noncollapsible hose supplies water to the pumping stations. Suction hoses are installed on the suction side of each pump to prevent collapse of the hose under high suction pressures.
- j Storage Assemblies. Two storage assemblies are supplied with the TWDS. Each assembly consists of hoses, gate valves, tees and a 20K collapsible fabric tank. The storage assemblies are used to store water for use by the distribution points. Major components of the storage assemblies include.
- (1) 4-inch Gate Valves. Hand operated gate valves control water flow from the main hose line to the 20K collapsible fabric tanks.
 - (2) 20K Collapsible Fabric tanks. The tank can store up to 20,000 gallons of potable water. The tanks expand and become pillow shape when filled. Handles on the sides of the tank aid movement and positioning of tank during setup and take down. Each tank is supplied with a ground cloth, couplings, vent tubes, elbows, drain valve and repair kit. Refer to the applicable TM for location and description of major components on the water tanks.
- k Distribution Point. Two distribution points are used to treat and dispense water from the storage assemblies. Nozzle stands are provided to prevent dirt, sand and contamination from entering the nozzles and elbow valves. Each distribution point consists of the following components.
- (1) 125 gpm pump The 125 gpm, engine driven, centrifugal water pump is skid mounted with handles at both ends to aid lifting and positioning. Refer to the applicable TM for location and description of major components on the pump.
 - (2) Hypochlorination Unit. Self contained, skid mounted unit operated by system water flow. Automatically chlorinates water being dispensed. Refer to applicable TM for additional information on the Hypochlorination unit.
 - (3) Elbow valve Handwheel operated valve installed at the end of the distribution point discharge hose. Quick disconnect couplings on valve permit coupling to tanker trucks or other water transport vehicles.
 - (4) Distribution nozzle Hand operated nozzle dispenses water to small containers.

1-11. EQUIPMENT DATA (Refer to Table 1-1).

Table 1-1. Equipment Data

NOTE

The following equipment data is provided for reference only and may not be accurate for the equipment supplied with your system. Refer to the applicable equipment TM for specific equipment data.

HYPOCHLORINATION UNIT

Weight (dry).....	241 pounds
Length.....	33 inches
Width.....	26 inches
Height.....	28 inches
Chemical Tank Capacity	6 gallons
Flow rate.....	0-350 gallons per minute

600 GPM PUMP

Length (towbar extended).....	139 inches
Width.....	70 inches
Weight (dry).....	3052 pounds
Tire pressure.....	40 pounds per square inch
Output.....	600 gallons per minute at 350 foot head

125 GPM PUMP

Length.....	22 inches
Width.....	18 inches
Weight (dry).....	146 pounds
Fuel	Gasoline/Diesel
Output.....	125 gallons per minute at 50 foot head

20K COLLAPSIBLE WATER TANK

Length (full).....	26 5 feet
Width (full)	22.5 feet
Height (full)	5.5 feet
Weight (empty)	400 pounds
Capacity.....	20,000 gallons

TRIPLE CONTAINER (TRICON)

Length.....	96 inches
Width.....	77 5 inches
Height.....	96 Inches
Gross Weight.....	15,700 pounds
Tare	2,500 pounds
Volume	360 cubic feet

1-11. EQUIPMENT DATA (Refer to table 1-1)- cont.

Table 1-1. Equipment Data - cont

FLAKING BOX

Length.....	91 inches
Width.....	82 inches
Height.....	20 inches
Capacity.....	1,000 feet, 6-inch collapsible hose
Weight (full)	1600 pounds

Section III. PRINCIPLES OF OPERATION

1-12. SYSTEM TECHNICAL PRINCIPLES OF OPERATION.

- a. General. The Tactical Water Distribution System (T'WI)S described in this manual is configured for maximum storage and distribution capacity. Your mission requirements will determine how many of the system components must be connected and in what configuration. Additional components are supplied with the system to adapt the TWDS to varying site and operational needs.
- b. Triple Container (TRICON). Four tricons are supplied with the TWDS for storage of water system components. Each container is equipped with standard ISO corner fittings to allow lifting by overhead sling, and also permit coupling of three containers to form a 20- foot modular assembly. Stacking of loaded containers is limited to a height of five containers. For additional information on the triple container, refer to the applicable TM.
- c. Pumping Stations.

Five pumping stations are connected in series by 6-inch discharge hoses to form the water transfer portion of the TWDS. Pumping station No 1 acts as the lead pump and is located at the water source. Water is pumped from the source to pumping station No 2 located about two miles downline. Pumping station No 2 boosts system pressure and feeds the water to pumping station No 3. This process is repeated through the fifth pumping station. Pumping stations No 2 through 5 act as boost pumps to overcome pressure drops caused by hose line friction and rises in field elevation.

Water flow through the pumping stations is controlled by opening or closing the butterfly valves in the suction and discharge hoses. If a pumping station fails, water can be routed around the failed pump through the bypass hose to keep the down line pumps primed.

Each pumping station includes a trailer mounted 600 gpm pump, check valve, butterfly valves and 6-inch hose assemblies. Pump operation is controlled through a panel mounted on the unit. For additional information on principles of operation for the 600 gpm pump, refer to the applicable TM.

1-12. SYSTEM TECHNICAL RINCIPLS OF OPERATION - cont.

- d. Storage Assemblies. Each storage assembly contains a 20K collapsible fabric tank, 4-inch gate valve, tee and discharge hoses Water for filling the fabric tank is tapped off the main hose line by opening the inlet gate valve. When the tank is full, the gate valve is closed. A second 4-inch gate valve, supplied with the water tank, controls water flow from the water tank to the distribution point.
- e. Distribution Point. Each distribution point contains a 125 gpm pump, hypochlorination unit, 2-inch gate valves, discharge hoses, 1 1/2inch distribution nozzles and elbow valves. Water for operating the distribution point is received from the storage assembly.

The engine driven, self contained, 125 gpm centrifugal pump supplies water to the distribution nozzles and valves through the 2-inch discharge hoses. For additional information on principles of operation for the 125 gpm pump, refer to the applicable TM.

The Hypochlorination unit treats water being discharged from the distribution point with a hypochlorite solution. The solution is automatically injected into the water supply based on the water flow rate. The water supply must be tested and the hypochlorination unit adjusted to provide the correct ratio of hypochlorite solution as determined by medical personnel. For additional information on principles of operation for the hypochlorination unit, refer to the applicable TM.

Two 2-inch gate valves control water flow to each leg of the distribution point. Dispensing of water to consumers is controlled by hand operated distribution nozzles and elbow valves. Nozzle stands support dispensing equipment to prevent contamination.

1-12. SYSTEM TECHNICAL PRINCIPLES OF OPERATION - cont.

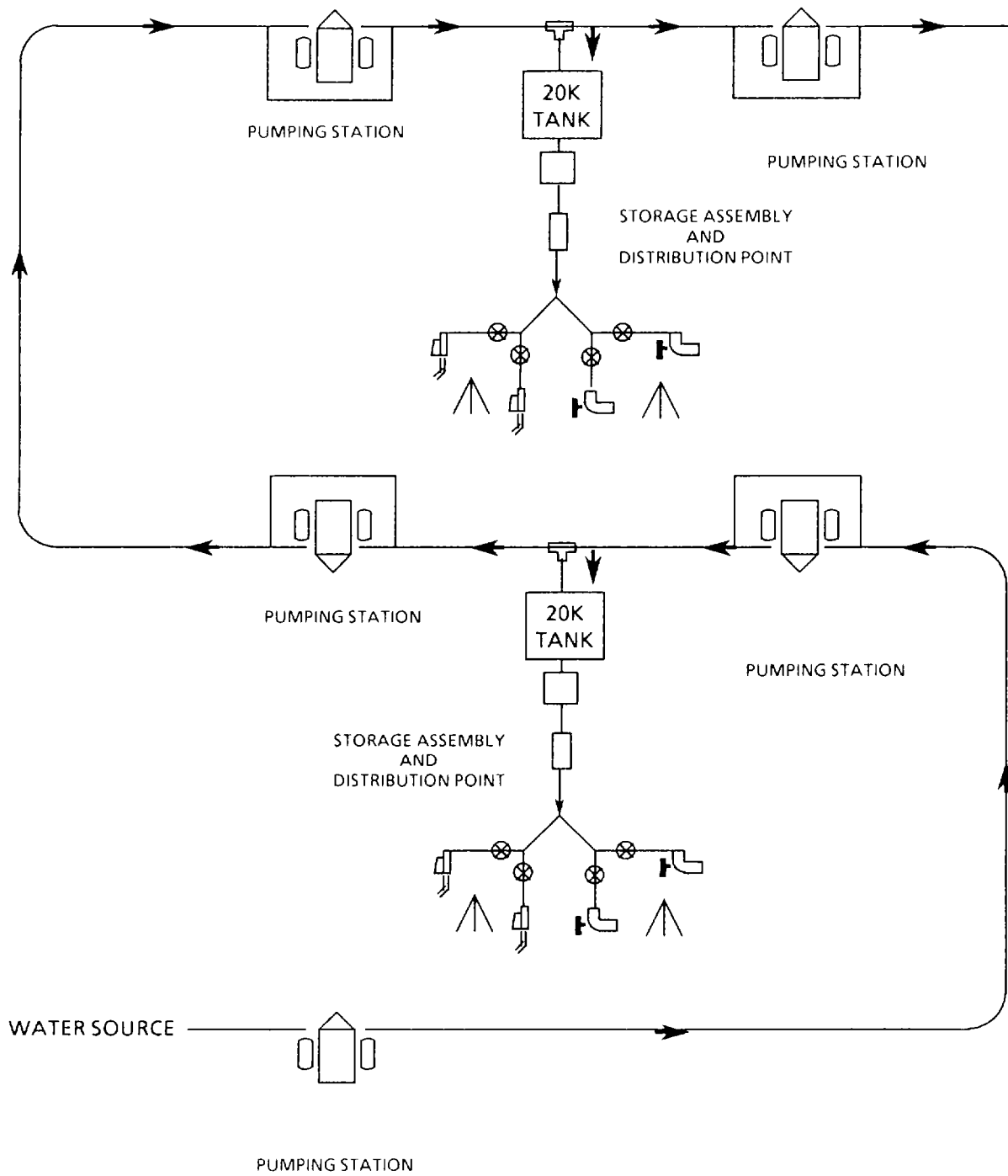

Figure 1-2. Flow Diagram.

1-11/(1-12 Blank)

CHAPTER 2

OPERATING INSTRUCTIONS

Section I. Description and Use of Operator's Controls and Indicators	2-1
2-1. Gate Valves.....	2-2
2-2. Distribution Nozzles	2-3
2-3. Butterfly Valves	2-4
2-4. Elbow Valves.....	2-5
2-5. Water Meter	2-6
2-6. Pressure Regulating Valve	2-7
Section II. Operator's Preventive Maintenance Checks and Services (PMCS)	2-8
2-7. General	2-8
2-8. PMCS Procedures.....	2-8
2-9. Leakage Definitions for Operator PMCS.....	2-9
2-10. Operator Preventive Maintenance Checks and Services.....	2-11
Section III. Operation Under Usual Conditions	2-23
2-11. Assembly and Preparation for Use.....	2-23
2-12. Initial Adjustment	2-62
2-13. Operating Procedures.....	2-63
2-14. Decals and Instruction Plates.....	2-68
2-15. Operating Auxiliary Equipment	2-68
2-16. Preparation for Movement	2-69
Section IV. Operation Under Unusual Conditions	2-94
2-17. Operation in Extreme Cold (Below 0°F).....	2-94
2-18. Operation in Extreme Heat	2-96
2-19. Operation in Dusty or Sandy Areas.....	2-96
2-20. Operation in Salt Water Areas.....	2-97
2-21. Emergency Produces.....	2-97
2-22. Decontamination Procedures.....	2-99

**Section I. DESCRIPTION AND USE OF OPERATORS
CONTROLS AND INDICATORS**

This section provides the operator with information needed to locate, identify, and use the controls and indicators on the Tactical Water Distribution System (TWDS). The components and controls identified in this section are applicable to the entire system.

Various models of 600 gpm pumps, 125 gpm pumps, hypochlorination units and 20K collapsible fabric tanks can be supplied with your water system. Refer to the applicable technical manuals for specific information on this equipment.

Refer to TM55-8145-200-13&P for description and use of operator's controls and indicators on the Tricon.

2-1. GATE VALVES.

Handwheel (2-inch Gate Valve)

Handwheels on the 2-inch gate valves are used to open or close the valve. Turning the handwheel all the way to the right closes the valve, to left opens the valve. The 2-inch gate valves are used in the distribution points to control and direct the flow of water to the distribution nozzles and elbow valves.

Handwheel (4-inch Gate Valve)

Handwheels on the 4-inch gate valves are used to open or close the valve. Turning the handwheel all the way to the right closes the valve, to left opens the valve. The 4-inch gate valves are used in the storage assemblies to control the flow of water to the 20K tanks.

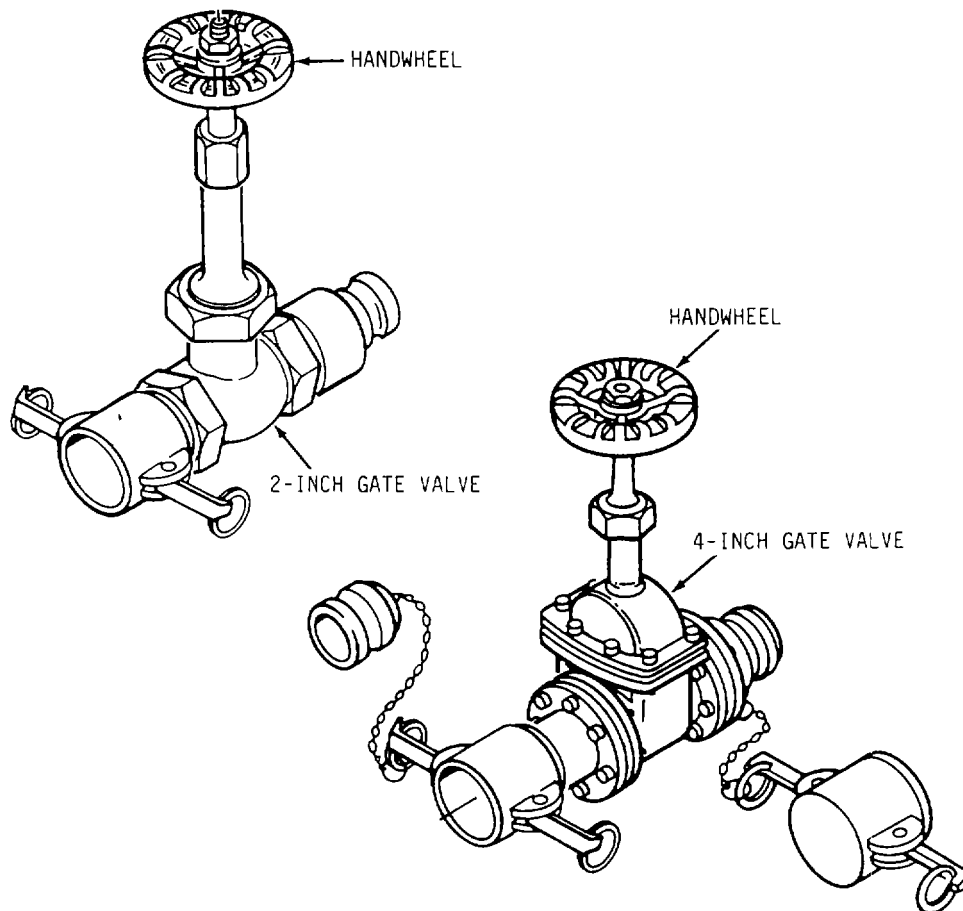

Figure 2-1. Gate Valves.

2-2. DISTRIBUTION NOZZLES.**Distribution Nozzle Handle (1-1/2 inch)**

The 1-1/2-inch distribution nozzles are operated by gripping the nozzle body and pulling up (squeezing) on the spring loaded control handle. Squeezing the handle opens an internal poppet valve and allows water flow through the nozzle. Releasing the handle stops water flow. The 1 1/2 inch distribution nozzles are used in the distribution points to dispense water to user containers.

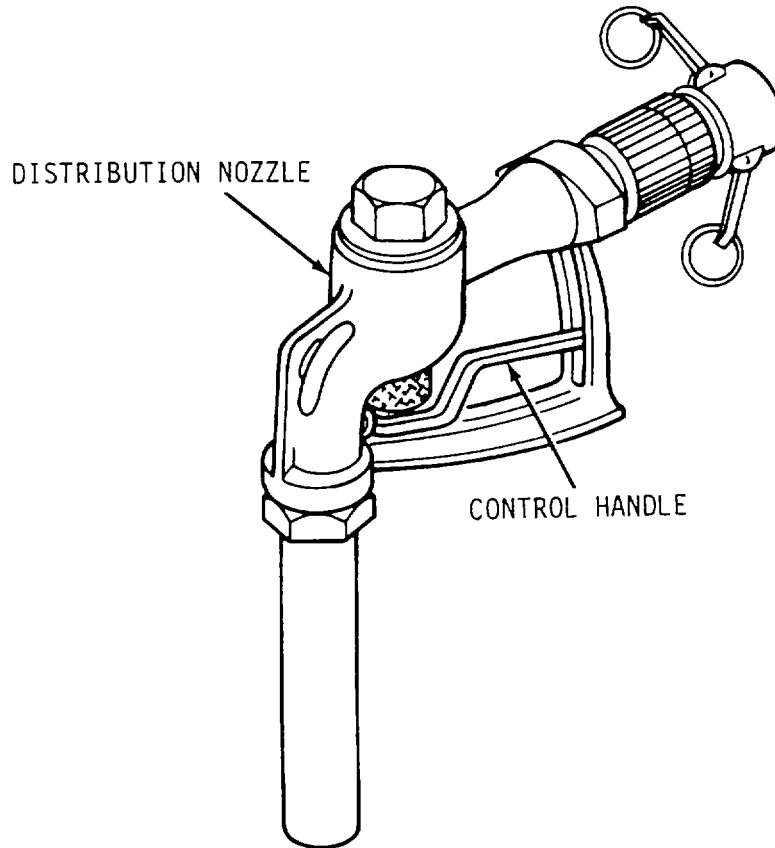

Figure 2-2. Distribution Nozzle

2-3. BUTTERFLY VALVES.

Handwheel

The butterfly valves control water flow through the 6-inch hoseline. A handwheel on the butterfly valve is used to open or close the valve. Turning the handwheel all the way to the right closes the valve, to left opens the valve.

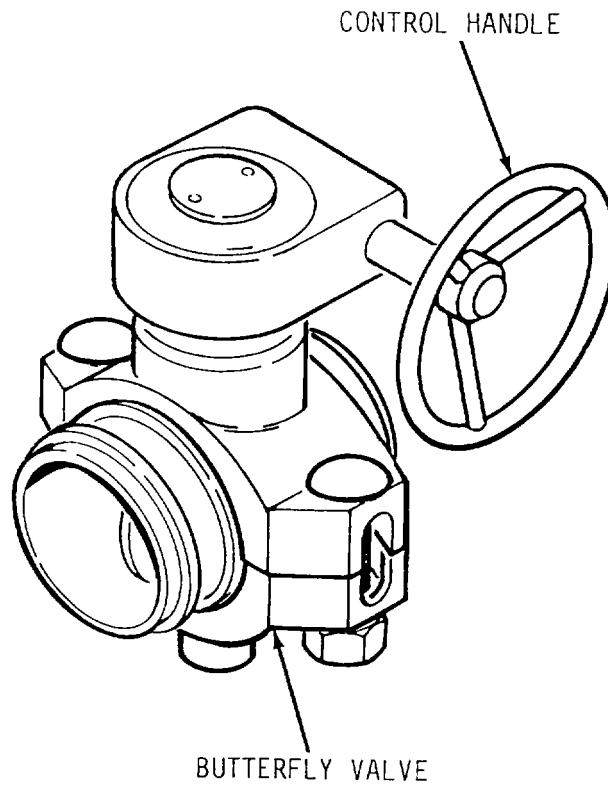

Figure 2-3. Butterfly Valves.

2-4. ELBOW VALVES.

Handwheel (2-inch Elbow Valve)

The elbow valves are operated by a handwheel extending from the valve body. Turning the handwheel all the way to the right closes the valve, to left opens the valve. The elbow valves are used in the distribution point to connect the water system to various pieces of water transport equipment. The 90° angle of the valve body aids in connecting the valve to the water transport equipment.

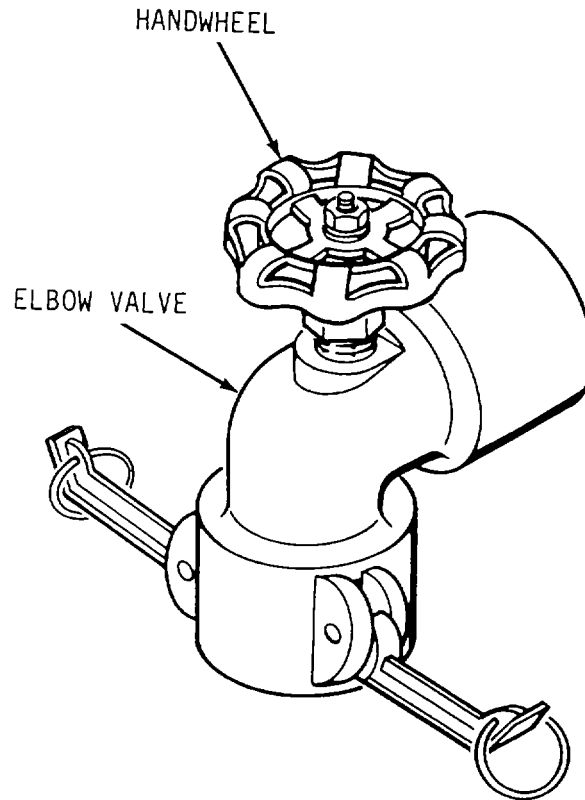

Figure 2-4. Elbow Valves

2-5. WATER METER.

Water Meter Indicator (4-inch)

The water meter indicator is located on top of the water meter and is protected by a cover. Lifting the cover reveals the face of the water meter indicator. The indicator shows the total number of gallons of water that have gone through the meter. The indicator cannot be reset. Two water meters are supplied with each TWDS.

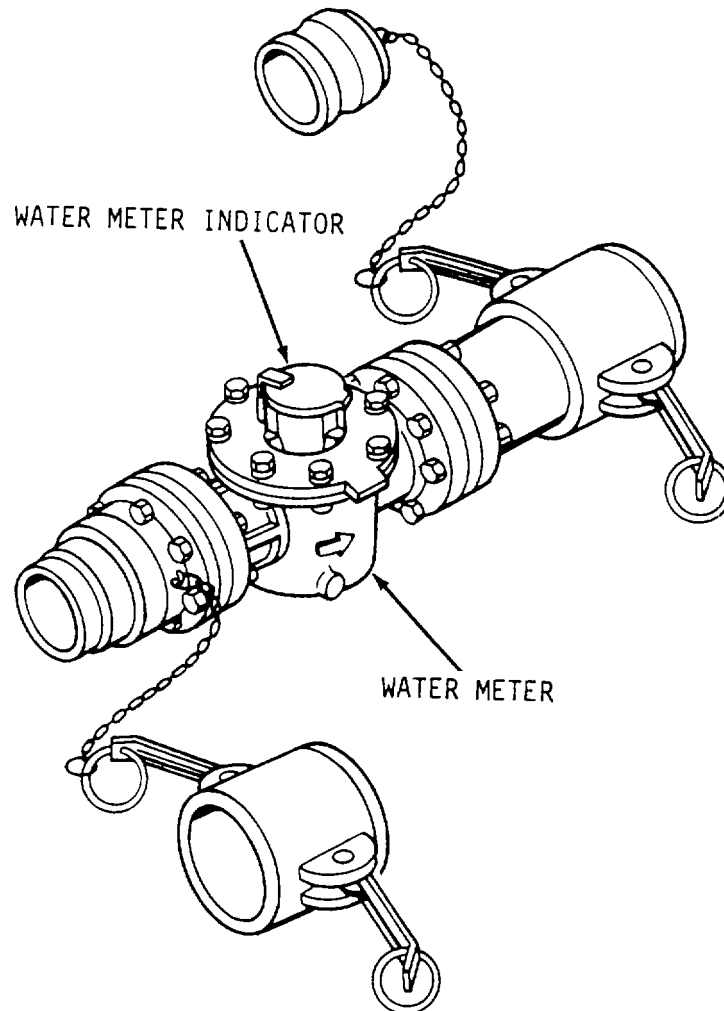

Figure 2-5. Water Meter.

2-6. PRESSURE REGULATING VALVE.

Isolation Valves (1, 2, and 3)

The skid mounted pressure regulating valve is installed where pressure is expected to exceed 225 psig in the 6-inch hoseline. The valve is preset to release outlet pressure at a rate of 75 psig. Three hand operated isolation valves control operation of the pressure regulating valve. All valves must be open during normal operation. Closing the isolation valves shuts off the pressure regulator when a reduction in hoseline pressure is not required.

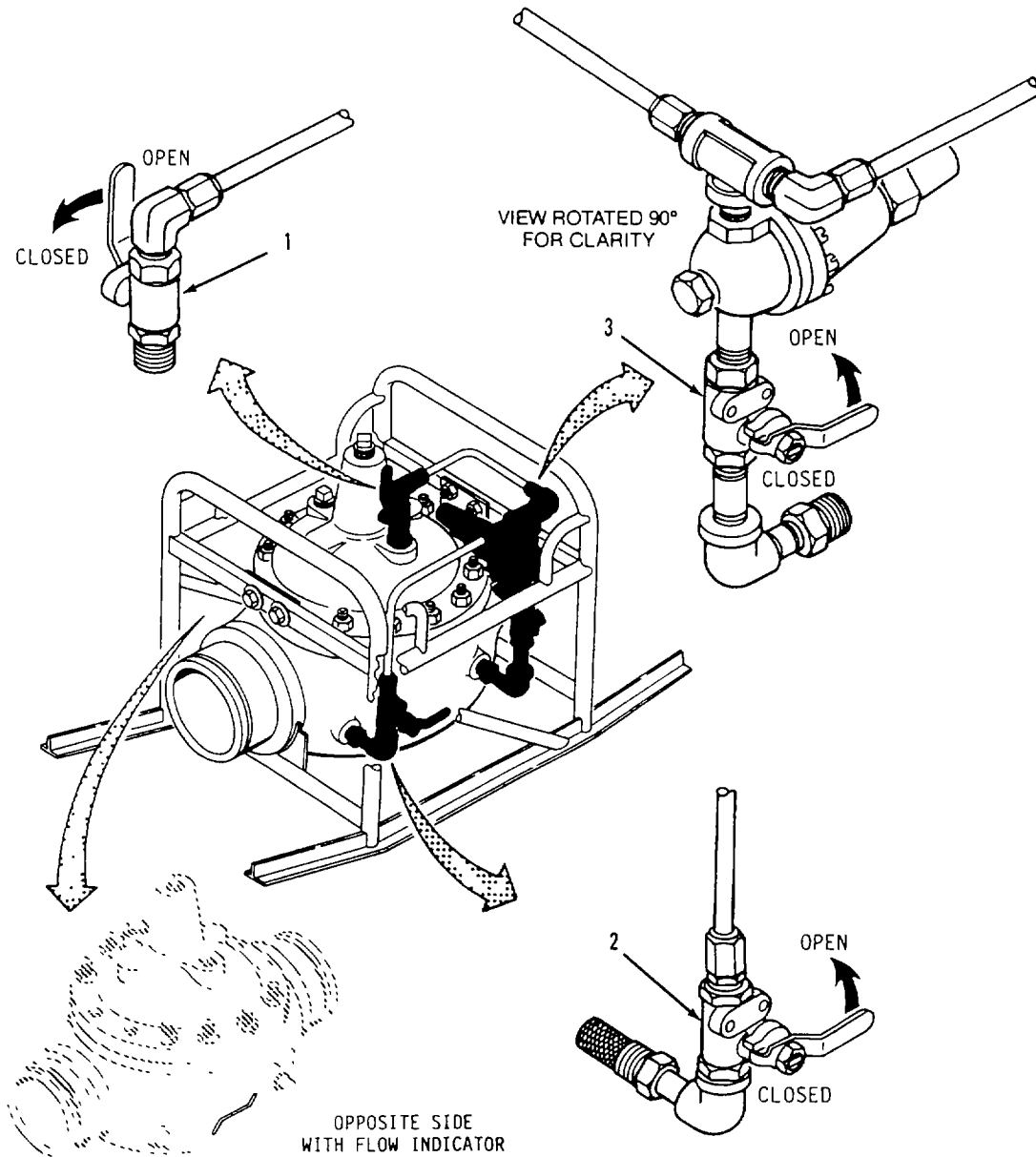

Figure 2-6. Pressure Regulating Valve.

Section II. OPERATOR PREVENTIVE MAINTENANCE CHECKS AND SERVICES (PMCS)

2-7. GENERAL.

Preventive Maintenance Checks and Services (PMICS) means systematic caring, inspecting and servicing of equipment to keep it in good condition and to prevent breakdowns. As the operator of the TWDS, your mission is to:

- a. Be sure to perform your PMCS each time you operate the TWDS. Always do you PMCS in the same order, so it gets be a habit. Once you've had some practice, you'll quickly spot anything wrong.
- b. Do your BEFORE (B) PMCS just before you operate the equipment. Pay attention to WARNINGS, CAUTIONs and NOTES.
- c. Do your DURING (D) PMCS while you operate the equipment. During operation means to monitor the equipment and its related components while it is actually being operated. Pay attention to WARNINGS, CAUTIONs and NOTES.
- d. Do your AFTER (A) PMCS right after operating the equipment Pay attention to WARNINGS, CAUTIONs and NOTES.
- e. Use DA Form 2404 (Equipment Inspection and Maintenance Worksheet) to record any faults that you discover before, during, or after operation, unless you can fix them. You DO NOT need to record faults that you fix.
- f. Be prepared to assist unit maintenance when required.
- g. When a check and service procedure is required for both WEEKLY and BEFORE intervals, it is not necessary to do the procedure twice if the equipment is operated during the weekly period.

2-8. PMCS PROCEDURES (Refer to figure 2-7).

- a. Your Preventive Maintenance Checks and Services, Table 2-1, lists inspections and care required to keep your equipment in good operating condition. It is setup so you can make BEFORE (B) OPERATION checks as you walk around the equipment.
- b. The "INTERVAL" column of Table 2-1 tells you when to do a certain check or service.
- c. The "LOCATION, ITEM TO CHECK/SERVICE" column of Table 2-1 tells you the name of the item to be checked or serviced and where the item is located.
- d. The "PROCEDURE" column of Table 2-1 tells you how to do required checks and services. Carefully follow these instructions. If you do not have tools, or if the procedure requires it, notify your supervisor.

2-8. PMCS PROCEDURES- cont.**NOTE**

Term "ready/available" and "mission capable" refer to the same status. Equipment is on hand and ready to perform its combat missions. (See DA Pam 738-750).

- e. The "EQUIPMENT IS NOT READY/AVAILABLE IF:" column in Table 2-1 tells you when your equipment is not mission capable and why the system cannot be used.
- f. If the equipment does not perform as required, refer to Chapter 3, Section II, Troubleshooting.
- g. If anything looks wrong and you can't fix it, write it on your DA Form 2404. IMMEDIATELY, report it to your supervisor.
- h. The following are checks that are common to the entire water system.
 - (1) Keep the equipment clean. Remove dirt, sand and debris from quick disconnect couplings, hose ends, gate valves and distribution nozzles to prevent excessive wear and contamination of the water system Use soap and water to remove dirt. Do not contaminate system with any type of cleaning solvent.
 - (2) Bolts, nuts and screws Check them for obvious looseness, missing, bent or broken condition on gate valves. If you find a bolt, nut or screw you think is loose, tighten it or report it to your supervisor.
 - (3) Hoses Look for wear, damage and leaks Make sure coupling clamps and quick disconnect couplings are tight Wet spots show leaks, but a stain around a fitting or connector can also mean a leak. If leak comes from a loose fitting or coupling, tighten it. If something is broken or worn out, report it to your supervisor.
- i. When you check for "operating condition", look at the component to see if it's serviceable.

2-9. LEAKAGE DEFINITIONS FOR OPERATOR PMCS.

It is necessary for you to know how fluid leakage affects the status of the equipment. Following are types are types/classes of leakage an operator needs to know to be able to determine the status of the water system Learn these leakage definitions and remember - when in doubt, notify your supervisor.

CAUTION

- * Equipment operation is allowable with minor leakages (Class I or II). Of course, consideration must be given to fluid capacity in the system. When in doubt, notify your supervisor.
 - * When operating with Class I or II leaks, continue to check fluid levels as required in your PMCS.
 - * Class III leaks should be reported immediately to your supervisor.
- a. Class I - Seepage of fluid (as indicated by wetness or discoloration) not great enough to form drops.

2-9. LEAKAGE DEFINITIONS FOR OPERATOR PMCS - cont.

- b. CLASS II - Leakage of fluid great enough to form drops but not enough to cause drops to drip from item being checked/inspected.
- c. CLASS III - Leakage of fluid great enough to form drops that fall from item being checked/inspected.

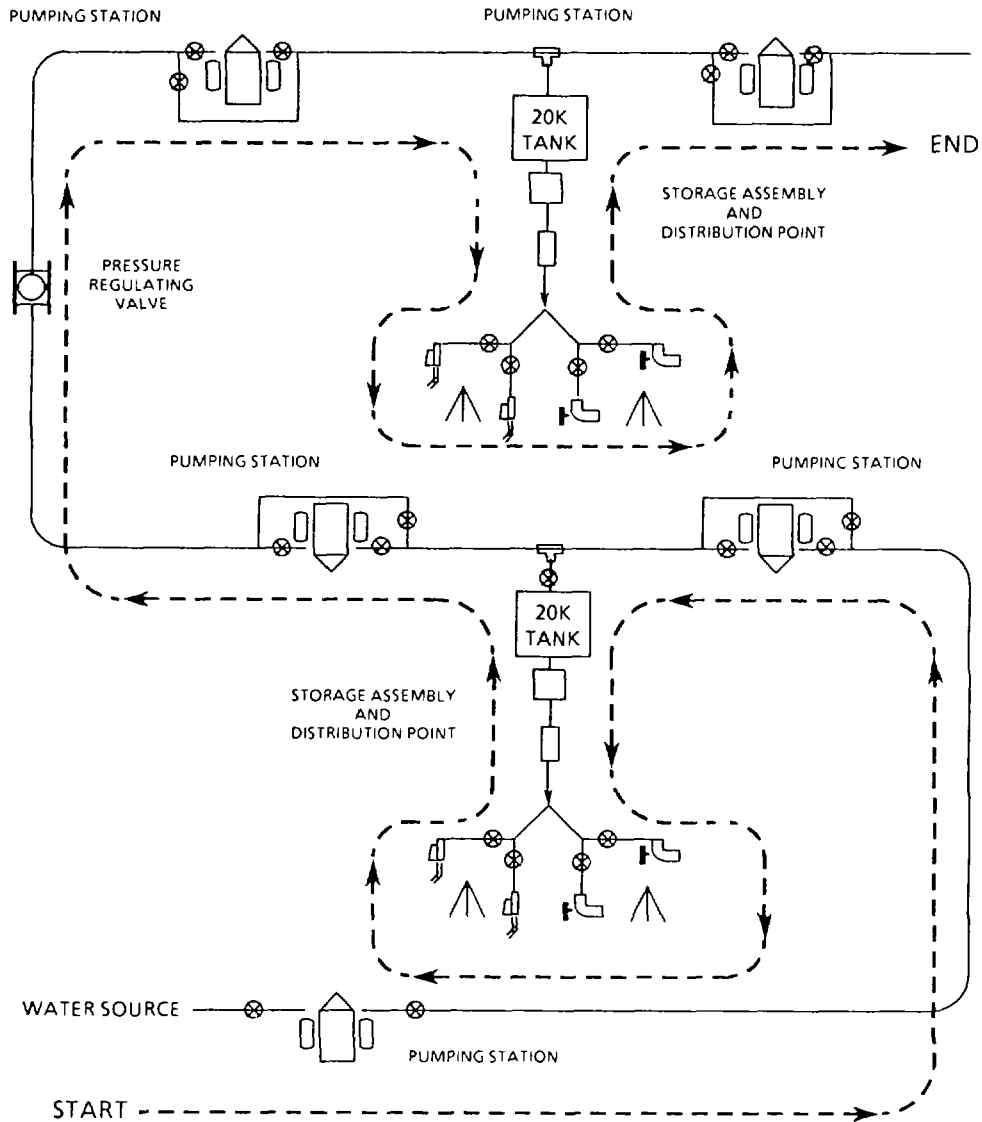

Figure 2-7. PMCS Routing Diagram.

2-10. OPERATOR PREVENTIVE MAINTENANCE CHECKS AND SERVICES (Refer To Table 2-1).

Table 2-1. Operator Preventive Maintenance Checks and Services for Model TWDS20.

NOTE

If the equipment must be kept in continuous operation, do only the procedures that can be done without disturbing operation. Make complete checks and services when the equipment is shut down.

ITEM NO.	INTERVAL	LOCATION ITEM TO CHECK/ SERVICE	PROCEDURE	NOT FULLY MISSION CAPABLE IF:
1	Before	<p style="text-align: center;"><u>PUMPING STATIONS</u></p> <p>Pipe Fitting (wye)</p>	<p>a. Inspect fitting for cracks, splits and broken welds.</p> <p>b. Inspect for missing, loose or damaged couplings.</p>	<p>Fitting cracked or split Clamps missing or damaged.</p>
2	Before	Butterfly Valves	<p>a. Inspect valve body for cracks</p> <p>b. Inspect for missing, loose or damaged handwheel.</p> <p>c. Check operation of valve. Valve handwheel should turn freely without sticking.</p> <p>d. Inspect for missing, loose or damaged coupling clamps.</p>	<p>Valve stuck, cracked or broken Clamps missing or damaged.</p>
3	Before	Suction Hoses	<p>a. Inspect hose for cuts, tears and deep abrasions.</p> <p>b. Inspect for open, cracked, or broken coupling clamps.</p> <p>c. Inspect for crimped, collapsed or flattened hose.</p>	<p>Hose cut or torn.</p> <p>Coupling clamps cracked or broken.</p>
4	Before	600 Gpm Pump	<p>Perform "BEFORE" PMCS in accordance with the applicable TM.</p>	

Table 2-1. Operator Preventive Maintenance Checks and Services for Model TWDS20 - cont.

ITEM NO.	INTERVAL	LOCATION ITEM TO CHECK/ SERVICE	PROCEDURE	NOT FULLY MISSION CAPABLE IF:
5	Before	Check Valves	a. Make sure valves are Installed properly. Arrow on valve body must be pointing away from pump (downline). b. Inspect for cracked valve body. c. Inspect for open, cracked or broken coupling clamps	Valve not installed properly or valve body cracked. Coupling clamp Damaged.
6	Before	Pressure Relief Valves	a. Inspect for cracked valve body b. Inspect for missing, loose or damaged coupling clamps	Valve body cracked. Clamps missing or damaged
7	Before	Discharge Hoses a	a. Inspect hoses for cuts, tears and deep abrasions. b. Inspect for open, cracked, or broken coupling clamps. c. Check for and straighten kinked hoses.	Hoses cut or torn. Coupling clamps cracked or broken

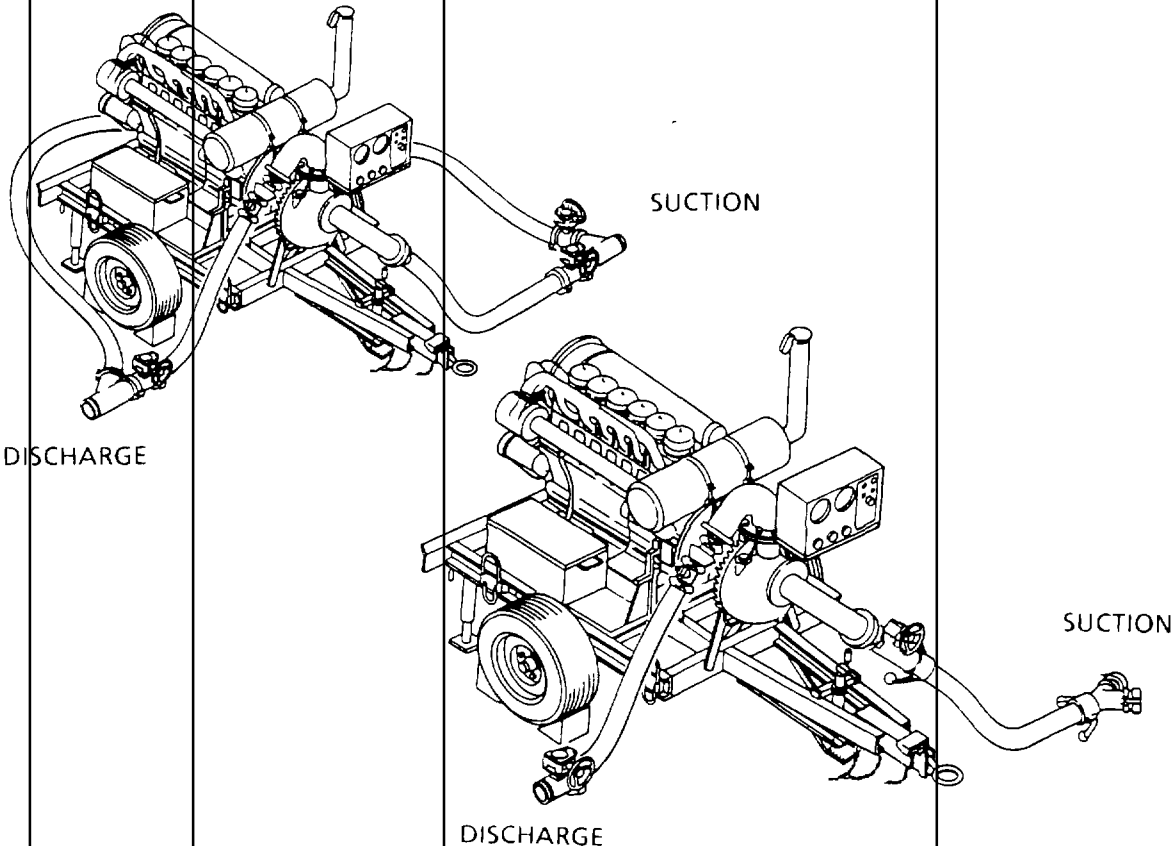

Table 2-1. Operator Preventive Maintenance Checks and Services for Model TWDS20 - cont.

ITEM NO.	INTERVAL	<u>LOCATION</u> ITEM TO CHECK/ SERVICE	PROCEDURE	NOT FULLY MISSION CAPABLE IF:
8	Before	<p><u>FLAKING BOX</u> <u>(HOSE LINE)</u></p> <p>Discharge Hoses</p>	<p>a. Inspect hose for cuts, tears and deep abrasions.</p> <p>b. Inspect for open, cracked, or broken coupling clamps.</p> <p>c. Check for and straighten kinked hoses.</p>	<p>Hoses cut or torn.</p> <p>Coupling clamps cracked, broken or missing.</p>
9	Before	Swivels	<p>a. Check location of swivels in hose line. Swivels must be installed at 1,000 foot intervals (two hose lengths).</p> <p>b. Inspect swivel bodies for cracks</p> <p>c. Inspect for open, cracked or broken coupling clamps.</p> <p>d. Check that swivel moves freely.</p>	<p>Swivels not installed properly, cracked or damaged.</p> <p>Coupling clamps missing, cracked or broken. Swivel stuck or jammed.</p>
				

Table 2-1. Operator Preventive Maintenance Checks and Services for Model TWDS20 - cont.

ITEM NO.	INTERVAL	LOCATION ITEM TO CHECK/ SERVICE	PROCEDURE	NOT FULLY MISSION CAPABLE IF:
10	Before	<u>ROADWAY CROSSING GUARDS</u>	Inspect for collapsed, crushed or damaged roadway crossing guards.	Crossing guard crushed, smashed or bent onto hose.
11	Before	<u>SUSPENSION KITS</u>	a. Check security of hose saddles, support cables and tie downs b. Inspect suspended hoseline for cuts, tears and abrasions at hose saddles. Saddles should be spaced five feet apart for correct hose line support.	Support cables or tie downs loose, broken or damaged. Hoses cut or torn.
12	Before	<u>PRESSURE REGULATING VALVE</u>	a. Inspect valve body for cracks and loose or missing attaching hardware. b. Inspect for cracked welds and bent or twisted components on skid c. Inspect for missing, loose or damaged coupling clamps d. Check that bypass valves open/close freely.	Valve body cracked or damaged. Coupling clamps missing, cracked or broken. Bypass valves stuck or jammed.
13	Before	<u>PRESSURE RELIEF VALVE</u>	a. Inspect body of pressure relief valve for cracks. b. Check for open, cracked or broken coupling clamps.	Valve cracked or broken.

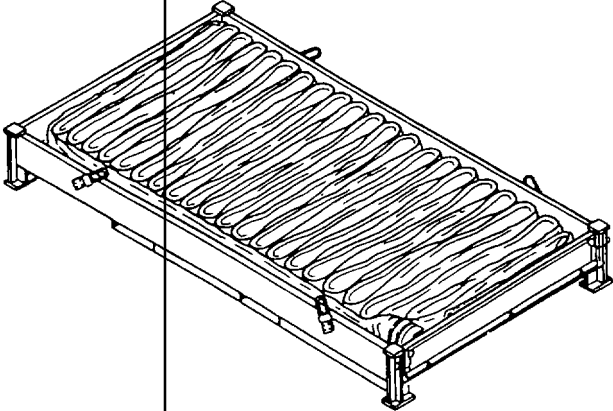
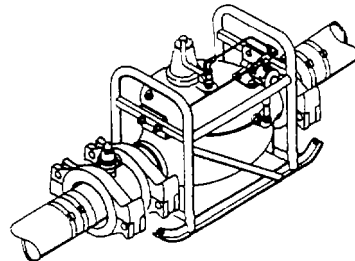

Table 2-1. Operator Preventive Maintenance Checks and Services for Model TWDS20 - cont.

ITEM NO.	INTERVAL	<u>LOCATION</u> ITEM TO CHECK/ SERVICE	PROCEDURE	NOT FULLY MISSION CAPABLE IF:
		<u>STORAGE ASSEMBLY</u>		
14	Before	Tee	Inspect tee bodies for cracks and corrosion.	Tee cracked or damaged.
15	Before	Gate Valve (4-inch)	<ul style="list-style-type: none"> a. Inspect for loose, broken, or missing hand wheel. Rotate hand wheel. Valve should turn freely b. Inspect valve body for cracks and external damage. c. Inspect for cracked, bent or broken quick disconnect couplings. d. Check for loose or missing attaching hardware. 	Hand wheel broken or missing. Valve will not turn. Valve body cracked or damaged. Coupling cracked or broken. Attaching hardware Missing.
16	Before	Discharge Hoses	<ul style="list-style-type: none"> a. Inspect hoses for cuts, tears and deep abrasions. b. Inspect for cracked and bent or broken couplings. c. Check for and straighten kinked hoses. 	Hoses cut or torn. Couplings cracked or broken.
17	Before	Water Meter	<ul style="list-style-type: none"> a. Inspect for cracked or broken cover or indicator. b. Inspect meter body of cracks and external damage. 	Meter body cracked or Damaged. Meter indicator broken.
				

Table 2-1. Operator Preventive Maintenance Checks and Services for Model TWDS20 - cont.

ITEM NO.	INTERVAL	<u>LOCATION</u> ITEM TO CHECK/ SERVICE	PROCEDURE	NOT FULLY MISSION CAPABLE IF:
18	Before	20K Collapsible Fabric Tank	Perform "BEFORE" PMCS in accordance with the applicable TM.	
19	Before	<u>DISTRIBUTION POINT</u> Suction Hoses	a. Inspect hoses for cuts, tears and deep abrasions. b. Inspect for cracked and bent or broken couplings. c. Check for and straighten kinked hoses. d. Inspect for crimped, collapsed or flattened hose.	Hoses cut, torn crimped or crushed. Couplings cracked or broken.
20	Before	125 Gpm Pump	Perform "BEFORE" PMCS in accordance with the applicable TM.	
21	Before	Discharge Hoses	a. Inspect hoses for cuts, tears and deep abrasions. b. Inspect for cracked and bent or broken couplings. c. Check for and straighten kinked hoses.	Hoses cut or torn. Couplings cracked or broken.
22	Before	Hypochlorination Unit	Perform "BEFORE" PMCS in accordance with the applicable TM	
23	Before	Gate Valves (2-inch)	a. Inspect for loose, broken, or missing hand wheel. Rotate hand wheel. Valve should turn freely. b. Inspect valve body for cracks and external damage. c. Inspect for cracked and bent or broken couplings.	Valve cracked, broken or stuck.
24	Before	Distribution Nozzles (1-1/2 inch)	a. Inspect for bent or damaged nozzle body and tube. b. Inspect for bent, broken, or stuck control handle.	Distribution nozzle damaged or defective.

Table 2-1. Operator Preventive Maintenance Checks and Services for Model TWDS20 - cont.

ITEM NO.	INTERVAL	<u>LOCATION</u> ITEM TO CHECK/ SERVICE	PROCEDURE	NOT FULLY MISSION CAPABLE IF:
25	Before	Elbow Valves	a. Inspect for loose, broken, or missing hand wheel Rotate hand wheel. Valve should turn freely. b. Inspect valve body for cracks and external damage. c. Inspect for cracked and bent or broken couplings.	Valve cracked, broken or stuck.
26	Before	Nozzle Stands	Inspect for broken chains, missing hardware, and bent or cracked legs.	
27	During	SUCTION HOSES (6-inch x 10-feet)	a. Inspect hoses and coupling clamps for leaks. b. Inspect for crimped, collapsed or flattened hose.	Class III leak.
28	During	<u>PUMPING STATIONS</u> Pipe Fitting (wye)	Inspect fitting and coupling clamps for leaks.	Class III leak.
29	During	Butterfly Valves	Inspect for leaks at valve stem and coupling clamps.	Class III leak.
30	During	Suction Hoses	a. Inspect hoses and coupling clamps for leaks. b. Inspect for crimped, collapsed or flattened hose.	Class III leak.
31	During	600 Gpm Pump	Perform "DURING" PMCS contained in the applicable TM.	
32	During	Check Valve	Inspect valve body for leaks.	Class III leak.
33	During	Pressure Relief Valves	Inspect valve body and coupling clamps for leaks.	Class III leak.
34	During	Discharge Hoses	a. Inspect hoses and coupling clamps for leaks. b. Check hoses for kinks Straighten hoses.	Class III leak.

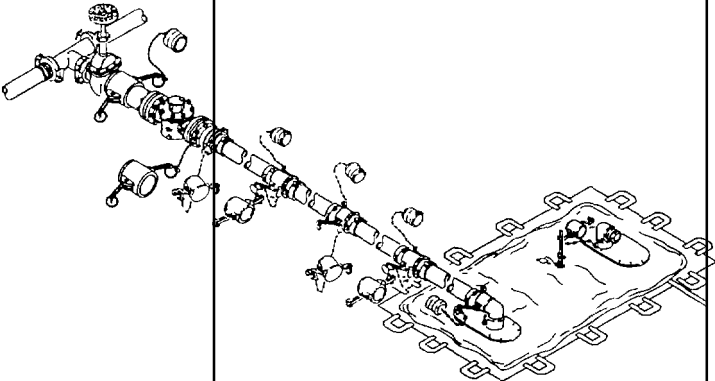
Table 2-1. Operator Preventive Maintenance Checks and Services for Model TWDS20 - cont.

ITEM NO.	INTERVAL	<u>LOCATION</u> ITEM TO CHECK/ SERVICE	PROCEDURE	NOT FULLY MISSION CAPABLE IF:
35	During	<u>FLAKING BOX</u> Discharge Hoses	a. Inspect hoses and coupling clamps for leaks b. Check hoses for kinks Straighten hoses. c. Check that hose is not twisted.	Class III leak.
36	During	Swivels	Inspect for leaks at coupling clamps and swivel body.	Class III leak.
37	During	ROADWAY CROSSING GUARDS	a. Inspect crossing guard for evidence of crushing caused by heavy vehicles. b. Check for hoseline damage at crossing guard.	Hoseline damaged.
38	During	SUSPENSION KITS	a. Inspect suspended hoses for leaks. b. Check security of suspension components.	Class III leak.
39	During	<u>PRESSURE REGULATING VALVE</u>	Inspect valve body and coupling' clamps for leaks.	Valve will not reduce system pressure. Class III leak.
40	During	<u>PRESSURE RELIEF VALVE</u>	Inspect valve body and coupling clamps for leaks.	Class III leak.
41	During	<u>STORAGE ASSEMBLY</u> Tee	Inspect tee and coupling clamps for Leaks.	Class III leak.
42	During	Gate Valves (4-inch)	Inspect for leaks at valve stem, flange gaskets and couplings.	Class III leak.
43	During	Discharge Hoses a	Inspect hoses for leaks and loose or unlocked couplings. b. Check hoses for kinks Unkink hoses.	Class III leak.
44	During	Water Meter	a. Inspect for proper operation of meter indicator. b. Inspect for leaks at flange gaskets and couplings.	

Table 2-1. Operator Preventive Maintenance Checks and Services for Model TWDS20 - cont.

Item No.	Internal	Location	Procedure	Not Fully Mission Capable If:
		Item to Check/Service		
45	During	20K Collapsible Fabric Tanks	Perform "DURING" PMCS contained in the applicable TM	
		<u>DISTRIBUTION POINT</u>		
46	During	Suction hoses	a. Inspect hoses for leaks and loose or unlocked couplings b. Inspect for crimped, collapsed or flattened hose	Class III leak
47	During	125 GPM Pump	Perform "DURING" PMCS contained in the applicable TM	
48	During	Discharge Hoses	Inspect hoses for leaks and loose or unlocked couplings b. Check hoses for kinks. Unkink hoses	Class III leak.
49	During	Hypochlorination Unit	Perform "DURING" PMCS contained in the applicable TM	
50	During	Gate Valves (2-inch)	Inspect for leaks at valve stem and coupling	Class III leak
51	During	Distribution Nozzles (1-1/2 inch)	Inspect for leaks at control handle and couplings	Class III leak
52	During	Elbow Valves	Inspect for leaks at valve stem and coupling	Class III leak
53	After	<u>SUCTION HOSES</u> (6-inch X 10-feet)	a. Inspect couplings for damage and missing gaskets b. Inspect for torn, punctured or damaged hoses c. Inspect for crimped, collapsed or flattened hose.	Couplings damaged, gasket damaged or missing, hose punctured or torn
		<u>PUMPING STATIONS</u>		
54	After	Pipe Fitting (wye)	Inspect fitting for cracks and external damage.	Fitting cracked or damaged

Table 2-1. Operator Preventive Maintenance Checks and Services for Model TWDS20 - cont.

Item No.	Internal	Location <u>Item to Check/Service</u>	Procedure	Not Fully Mission Capable If:
55	After	Butterfly Valves	Inspect for loose, broken or missing control handle.	Control handle missing
56	After	Suction Hoses	a Inspect couplings for damage and missing gasket. b Inspect for crimped, collapsed or flattened hose	Couplings damaged, gasket damaged or missing, hose punctured or torn.
57	After	600 Gpm Pumps	Perform "AFTER" PMCS in accordance with the applicable TM	
58	After	Check Valves	Inspect valve for cracks and corrosion.	Valve cracked or damaged
59	After	Pressure Relief Valve	Inspect valve for cracks and corrosion.	Valve cracked or damaged
60	After	Discharge Hoses	a Inspect couplings for damage and missing gasket. b Inspect for torn, punctured or damaged hoses.	Couplings damaged gasket damaged or missing, hose punctured or torn.
61	After	<u>FLAKING BOX (HOSELINE)</u> Discharge Hoses	a Inspect couplings for damage and missing gasket. b Inspect for missing attaching bolts, nuts and hardware. c Inspect for torn, punctured or damaged hoses.	Couplings damaged, gasket damaged or missing, hose punctured or torn.
62	After	Swivels	a. Inspect couplings for damage and missing gasket. b Inspect for missing attaching bolts, nuts and hardware.	Coupling damaged, gasket damaged or missing, hardware missing.
63	After	<u>ROADWAY CROSSING GUARDS</u>	Check for crushed crossing guards.	Crossing guard not serviceable.
64	After	<u>SUSPENSION KITS</u>	a Check for excessive sag in suspension cable. b Inspect for damaged suspension cable and loose stakes or turnbuckles.	

Table 2-1. Operator Preventive Maintenance Checks and Services for Model TWDS20 - cont.

Item No.	Internal	Location <u>Item to Check/Service</u>	Procedure	Not Fully Mission Capable If:
65	After	<u>PRESSURE REGULATING VALVE</u>	a Inspect valve body for damage and corrosion. b Inspect for missing attaching bolts, nuts and hardware.	Valve body cracked or Damaged.
66	After	<u>PRESSURE RELIEF VALVE</u>	a Inspect valve body for external damage and corrosion b Inspect for loose or missing attaching bolts, nuts and hardware.	Valve body cracked or damaged.
67	After	<u>STORAGE ASSEMBLY</u> Tee	Inspect tee for external damage and corrosion	Tee cracked, damaged or severely corroded
68	After	Gate Valves (4-Inch)	a Inspect couplings for damage and missing gasket b Inspect for missing attaching bolts, nuts and hardware. c Inspect for bent or damaged valve stems	Coupling damaged, gasket damaged or missing, hardware missing.
69	After	Discharge Hoses	a. Inspect couplings for damage and missing gasket b. Inspect for missing attaching bolts, nuts and hardware c Inspect for torn, punctured or damaged hoses	Couplings damaged, gasket damaged or missing, hose punctured or torn.
70	After	Water Meter	a. Inspect quick disconnect couplings for damage and missing gasket, caps, or plugs b Inspect for missing attaching bolts, nuts and hardware c Inspect for cracked or damaged meter indicator	Water meter cracked or damaged.
71	Before	20K Collapsible Fabric Tank	Perform "AFTER" PMCS in accordance with the applicable TM	

Table 2-1. Operator Preventive Maintenance Checks and Services for Model TWDS20 - cont.

Item No.	Internal	Location <u>Item to Check/Service</u>	Procedure	Not Fully Mission Capable If:
72	After	<u>DISTRIBUTION POINT</u> Suction Hoses	a Inspect couplings for damage and missing gasket b Inspect for crimped, collapsed or flattened hose	Couplings damaged, gasket damaged or missing, hose punctured, kinked or crushed
73	After	125 Gpm Pump	Perform "AFTER" PMCS in accordance with the applicable TM.	
74	After	Discharge Hoses	a Inspect couplings for damage and missing gasket b Inspect for missing attaching bolts, nuts and hardware c Inspect for torn, punctured or damaged hoses	Couplings damaged, gasket damaged or missing, hose punctured or torn
75	After	Hypochlorination Unit	Perform "AFTER" PMCS in accordance with the applicable TM.	
76	After	Gate Valves (2-inch)	a Inspect couplings for damage and missing gasket b Inspect for missing attaching bolts, nuts and hardware.	Coupling damaged, gasket damaged or missing, hardware missing
77	After	Distribution Nozzles (1-1/2 Inch)	a Inspect couplings for damage and missing gasket, caps, or plugs b Check for missing nozzle tube caps.	Coupling damaged, gasket damaged or missing, hardware missing
78	After	Elbow Valves	a Inspect quick disconnect couplings for damage and missing gasket, caps, or plugs b Check for missing plugs.	Valve body cracked or damaged
79	After	Nozzle Stands	Inspect for bent or broken legs and broken chains	

Section III. OPERATION UNDER USUAL CONDITIONS**2-11. ASSEMBLY AND PREPARATION FOR USE.**a Site Selection.

- (1) Prior to installing TWDS equipment, a thorough study of the terrain is required. A general route for hoseline and general locations for the pumping stations, storage assemblies and distribution points can be determined from examination and comparison of maps, photographs and charts. A map and ground reconnaissance is essential. Some elements to be considered in selecting a route and installation sites for TWDS are:
 - (a) Whether TWDS will operate independently or as part of a large system.
 - (b) The assigned mission for TWDS (i.e., dispensing, storing or transferring water).
 - (c) Expected length of time TWDS will be required to operate.
 - (d) Elevation differences and distances TWDS will encounter along its route.
- (2) Organize a ground reconnaissance prior to installation of TWDS to determine exact locations for pumping stations, storage assemblies, and distribution points. If possible, site locations should be near or parallel to existing roads to ease transportation, assembly, inspection, maintenance and disassembly of the system. Avoid routes along the banks of streams, marshes, ponds, gulleys, ravines or other areas subject to flooding. Whenever possible, the hoseline should be laid out on firm, dry, level ground that allows easy access and is not subject to flooding.
- (3) Minimum requirements for selecting the route are as follows:
 - (a) A sketch of the proposed route.
 - (b) Odometer distances.
 - (c) Enough topographic information (surveying altimeter elevations) to establish relative altitude at various points along the hoseline route.
- (4) The following guidelines should be utilized to gain maximum effectiveness for installation and operation of the system:
 - (a) The route should be direct and present a minimum number of obstacles and obstructions.
 - (b) A route parallel to a secondary all-weather road is preferable to one along a heavily traveled road.
 - (c) If roadways do not exist or cannot be utilized, select a route that is accessible to vehicles required for laying the hoseline.
 - (d) Plan to locate junction of two hoseline lengths at installation sites for each boost pumping station and storage assembly.

2-11. ASSEMBLY AND PREPARATION FOR USE - cont.

- (e) Keep security precautions in mind. Utilize natural camouflage wherever possible and avoid routing hoseline through populated areas.
- (5) In selecting pumping station installation sites, the location of the lead or first pumping station will be determined by location of the water source. Boost pumping stations are intended to be spaced at approximately two mile intervals, assuming that the route is reasonably direct and terrain is level. However, a substantial rise or fall in elevation along the hoseline route may require adjustment of standard spacing intervals.
- (a) If the next downline pumping stations is substantially higher in elevation than the upline pumping station, the distance between them must be shortened.
 - (b) If the next downline pumping station is substantially lower in elevation than the upline pumping station, the distance between them must be lengthened.
- (6) Adjustments to spacing between pumping stations (due to elevation change) assure that water pressure will be maintained within optimum operational range. Under normal conditions, TWDS will deliver water to the suction port of each boost pumping station at a pressure of 20 psig. Whenever suction pressure falls below 20 psig, boost pumping stations are designed to begin reducing speed, when operated in the electric mode. Therefore, if an upline pumping station is substantially lower than the next downline station, and the elevation difference has not been offset by spacing adjustment, suction pressure at the downline pumping station may fall below 20 psig and cause that pump to slow down. This in turn will cause remaining downline boost pumping stations to slow down, seriously degrading overall performance of TWDS.
- (7) A ground profile (drawn on graph paper) and a pump spacing triangle can be utilized to determine the location of each boost pumping station. To construct a ground profile, first obtain a topographical map or other source material which provides accurate information concerning terrain along projected hoseline route. Then, using this information, draw a ground profile of the hoseline route on graph paper as follows (refer to figure 2-8).
- (a) Divide the horizontal base of the graph into spaces that represent uniform distances, such as 1000 ft intervals. However, any suitable scale can be used. The base of the graph represents the horizontal distance that the hoseline will cross.
 - (b) Divide the vertical, left-hand edge of the graph into spaces that represent uniform changes in elevation.
 - (c) At the left-hand edge of the graph, mark a point that represents the elevation of the lead pumping station.
 - (d) Continuing across the graph, mark points where significant changes in elevation occur along the hoseline route.
 - (e) To complete the ground profile, join the points marked on the graph with a straight line.

2-11. ASSEMBLY AND PREPARATION FOR USE - cont.

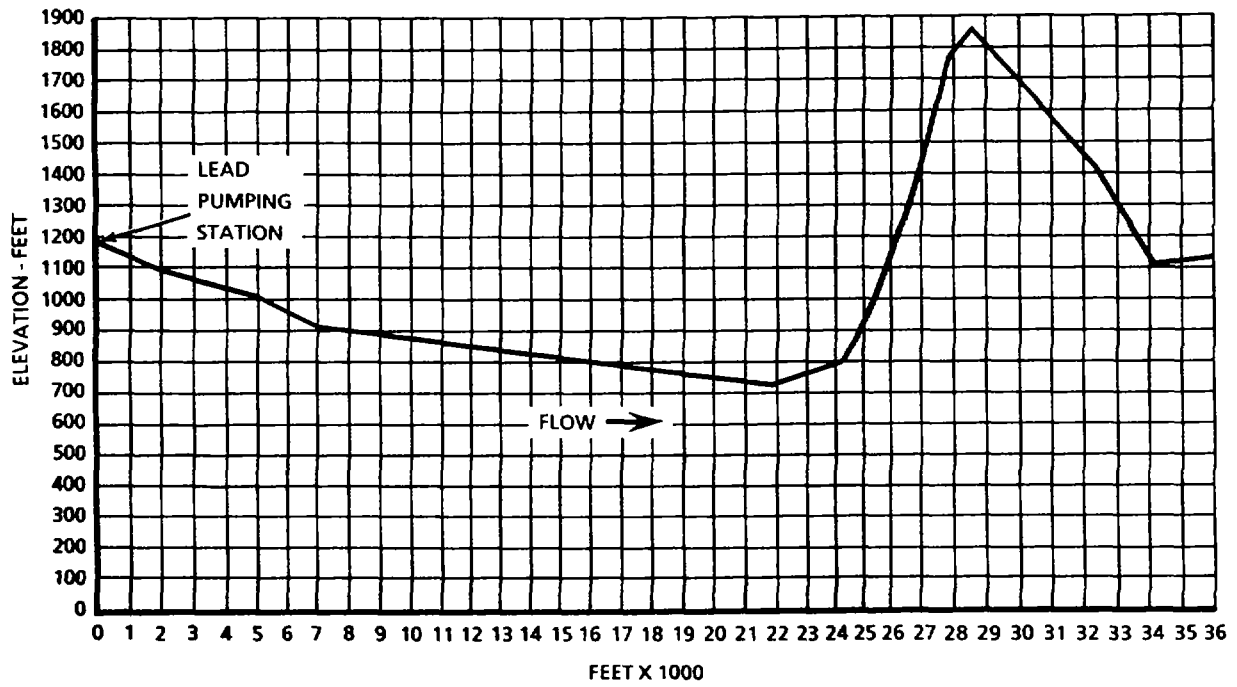

Figure 2-8. Ground Profile Chart.

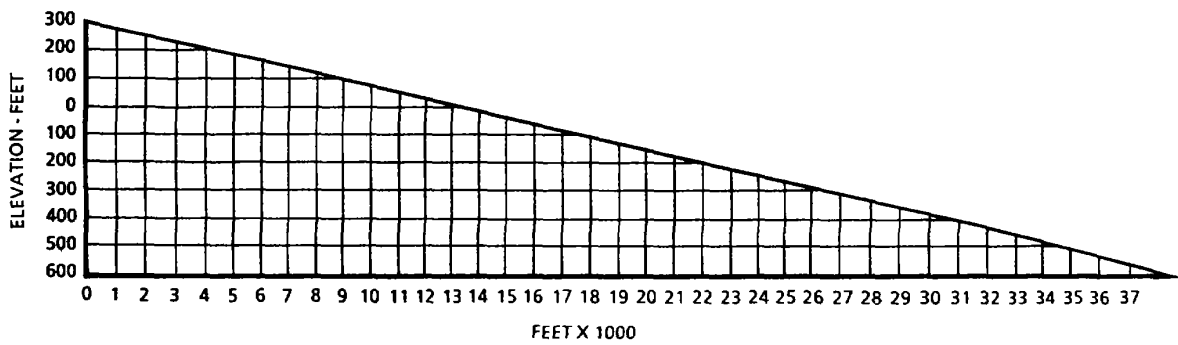

Figure 2-9. Spacing Triangle.

2-11. ASSEMBLY AND PREPARATION FOR USE - cont.

- (8) To construct a spacing triangle, obtain a piece of paper, transparent sheet, or cardboard thick enough to be used as a straightedge. Then proceed as follows (refer to figure 2-9).
 - (a) Divide the horizontal base of the triangle into spaces on the same uniform scale used to divide the base of the ground profile graph. Mark off spaces along the triangle base to at least 39,000 ft.
 - (b) Divide the vertical, left-hand edge of the triangle into spaces on the same uniform scale used to represent elevation changes on the ground profile. Mark off spaces along the vertical side of the triangle as follows:
 - (1) Zero represent the elevation of the pumping station
 - (2) The upper left-hand corner represents 300 ft above the pumping station.
 - (3) The lower left-hand corner represents 600 ft below the pumping station.
 - (c) Draw a straight, diagonal line from the 300 ft mark on the vertical scale to the 39,000 ft mark on the horizontal scale. This line will form the hypotenuse or long side of the triangle.
 - (d) Make sure all lines have a straight edge, cut the triangle along the three sides drawn (horizontal, vertical, and diagonal).
- (9) Using the ground profile and pump spacing triangle, determine the location of the first boost pumping station as follows (refer to figure 2-10).
 - (a) Place the pump spacing triangle on the ground profile.
 - (b) Aline the vertical side of the pump spacing triangle with the vertical (elevation) side of the ground profile, so that the zero mark of the spacing triangle is on the lead pumping station mark of the ground profile.
 - (c) Make sure the horizontal side of the spacing triangle is exactly parallel with the horizontal base of the ground profile. Horizontal spacing marks on both the pump spacing triangle and ground profile should be exactly alined.
 - (d) Mark the point at which the hypotenuse (or long side of the spacing triangle) crosses the ground profile. This will be the location of the first boost pumping station.

2-11. ASSEMBLY AND PREPARATION FOR USE - cont.

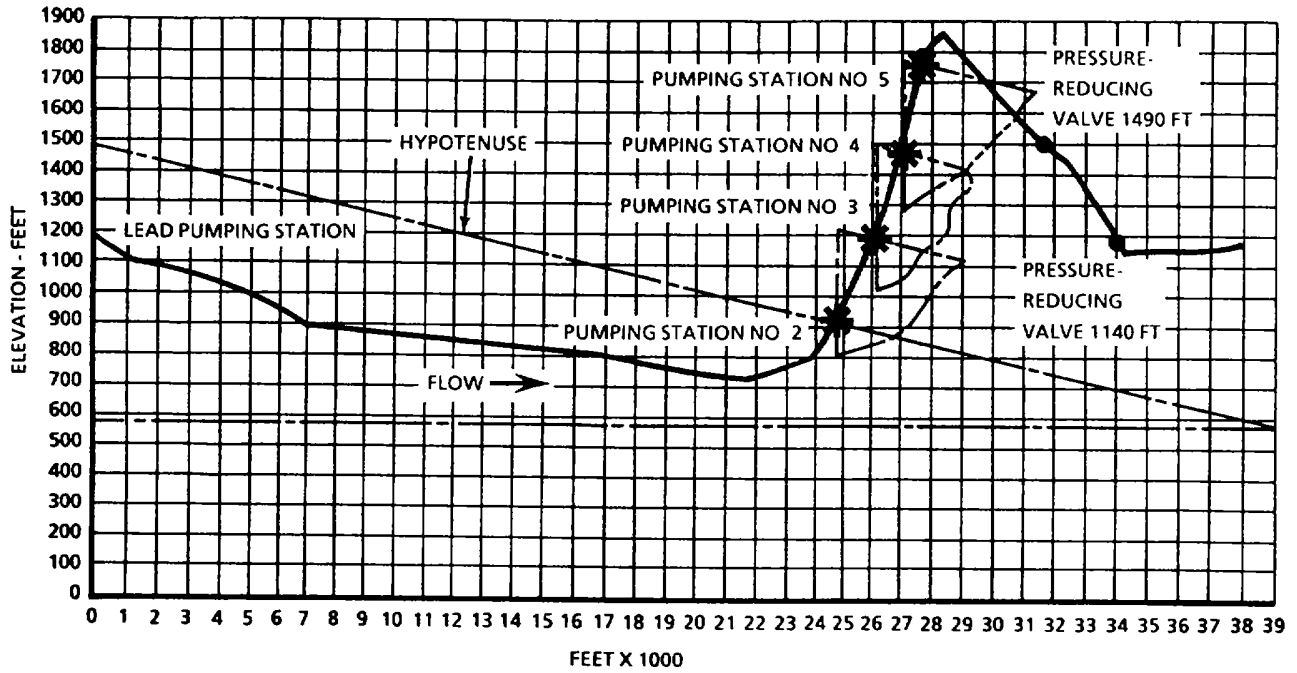

Figure 2-10. Locating Pumping Stations.

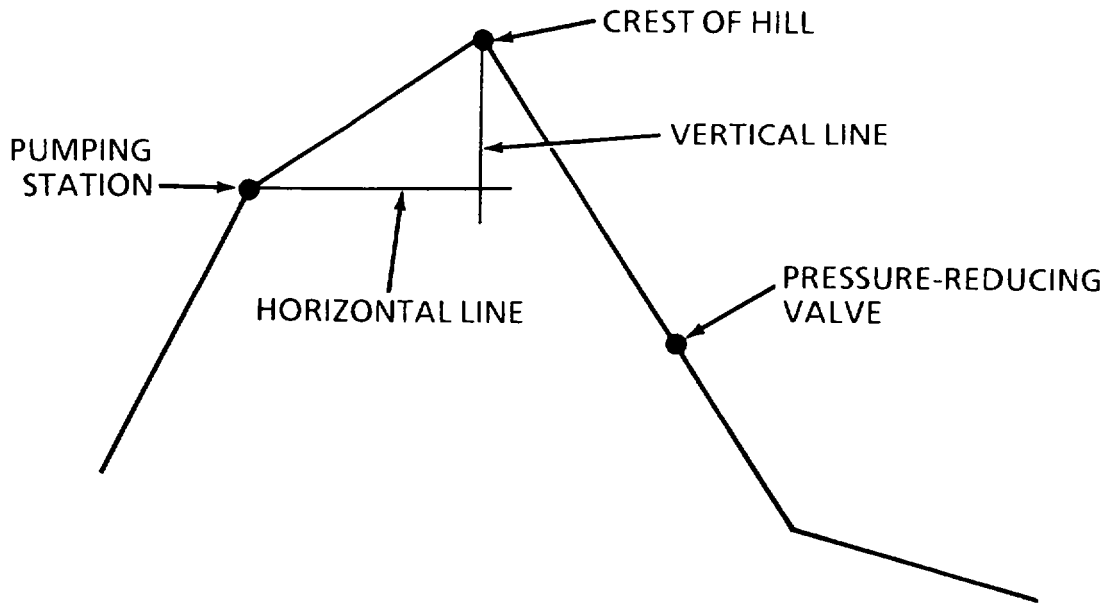

Figure 2-11. Locating Pressure Reducing Valve.

2-11. ASSEMBLY AND PREPARATION FOR USE - cont.

NOTE

If the level of ground profile is below base of pump spacing triangle, extend the line of the spacing triangle hypotenuse until it crosses the ground profile

- (10) To determine the location of the second boost pumping station, place the zero mark of the spacing triangle on the first boost pumping station mark of the ground profile. Mark the point at which the spacing triangle hypotenuse crosses the ground profile. Mark the point at which the spacing triangle hypotenuse crosses the ground profile. This will be the location of the second boost pumping station. Locations of successive boost pumping stations are determined in the same way.
- (11) After locations of pumping stations have been plotted, check ground profile for any sharp declines in elevation along hoseline route. An excessive drop in elevation will significantly increase the pressure of water as it flows downhill. If pressure builds to 225 psig, hoseline can rupture and equipment failure will result therefore, when the ground profile indicates a sharp elevation drop along the route, a pressure reducing valve must be installed in the hoseline.
- (12) To determine the location of the pressure reducing valve, refer to the ground profile and proceed as follows, (refer to figure 2-11).

- (a) Mark crest of hill on ground profile.
- (b) Draw a vertical line downward from the hill crest.
- (c) Determine location of pumping station closest to the crest (on uphill side).
- (d) Draw a horizontal line outward from pumping station until it intersects the vertical line.
- (e) Measure footage of horizontal line outward from pumping station until it intersects the vertical line.
- (f) Using formula provided below, determine total hoseline footage between pumping station and hill crest.

$$\text{Total hoseline footage} = \sqrt{a^2 + b^2}$$

(a = horizontal line footage)
(b = vertical line footage)

- (g) Using formula provided below, determine friction loss of total hoseline footage in terms of vertical feet:

$$\text{Total hoseline footage} \times 0.024 = \text{Vertical feet of friction loss in hoseline.}$$

(0.024 = friction loss conversion factor)

2-11. ASSEMBLY AND PREPARATION FOR USE - cont.

- (h) Using formula provided below, determine total feet of friction loss:

Vertical feet of friction loss in hoseline + Feet of elevation between pumping station and hill crest = Total feet of friction loss

- (i) Using formula provided below, convert total feet of friction loss into psi:

$$\frac{\text{Total feet of friction loss}}{2.31} = \text{friction loss in psi}$$
 (2.31 = psi conversion factor)

- (j) Using formula provided below, determine existing psi at hill crest

150 psi - psi of friction loss = psi at hill crest
 (150 psi = pumping station discharge pressure)

- (k) Using formula provided below, determine allowed additional psi before safety limit is reached:

225 psi - psi at hill crest = Allowed additional psi before reaching safety limit
 (225 psi = safety limit of pressure)

- (l) Using formula provided below, convert allowed additional psi into vertical feet:

Allowed additional psi x 2.31 = Allowed additional vertical footage before reaching safety limit.
 (2.31 = vertical footage conversion factor)

- (m) Using formula provided below, determine point at which pressure reducing valve must be installed in hoseline:

Altitude at hill crest - Allowed additional vertical footage = Pressure reducing valve installation point

- (13) If elevation continues to drop excessively beyond first pressure reducing valve installation point, a second pressure reducing valve must be installed in hoseline. Using formula provided below, determine point at which second pressure reducing valve must be installed in hoseline:

Altitude at first pressure reducing valve installation point - 346.5 = Second pressure reducing valve installation point
 (346.5 = allowed additional vertical footage before reaching safety limit)

2-11. ASSEMBLY AND PREPARATION FOR USE - cont.

- b Movement to Assembly Area. After location of source pumps and storage and distribution points have been determined, select an assembly area to unload all components of the TWDS system. Components are unpacked according to like items, inventoried, inspected and serviced if necessary.
- c Movement to Installation Sites. Place pump stations and storage/distribution points at selected installation sites. Place flaking boxes and other equipment used during flaking operation at selected area. Place TRICONS at a selected area for easy access.
 - (1) Place TRICONS, water tank storage chests, water pumps and hypochlorination units at selected installation sites.
 - (2) Unload 600 gpm pumps, flaking boxes, 125 gpm pump, hypochlorination units and 20K collapsible fabric tanks. To aid assembly, separate components into groups of similar parts.
 - (3) Unpack contents of each TRICON. To aid assembly, separate components into groups of similar parts during removal. For example, group all the 4-inch discharge hoses together, then all the 4-inch gate valves, 2-inch discharge hoses and so on until all components are unpacked.
- d Connection of Quick Disconnect Couplings. Refer to figure 2-12.

Components of the distribution point and water storage kits are equipped with quick disconnect couplings to permit rapid assembly and disassembly. The following instructions apply to installation and removal tasks for this equipment.

WARNING

To prevent system contamination and damage to the equipment, use care when connecting couplings to avoid getting dirt, sand and debris on coupling mating surfaces or in hoses. To prevent leaks and ensure tight connections, make sure gaskets are installed in all female quick disconnect couplings.

Connection

- (1) Lift locking arms (1) up and out from female coupling (2).
- (2) Remove plug (3) from female coupling (2).
- (3) Lift locking arms (4) up and out from cap (5).
- (4) Remove cap (5) from male coupling (6).
- (5) Position male coupling (6) in female coupling (2) and hold in place.
- (6) Pull both locking arms (1) back at the same time until arms are down against body of female coupling (2).

2-11. ASSEMBLY AND PREPARATION FOR USE - cont.

- (7) Verify that male coupling (6) and female coupling (2) are connected by pulling on couplings. Couplings should remain securely connected and locking arms (1) must remain snug against coupling body.

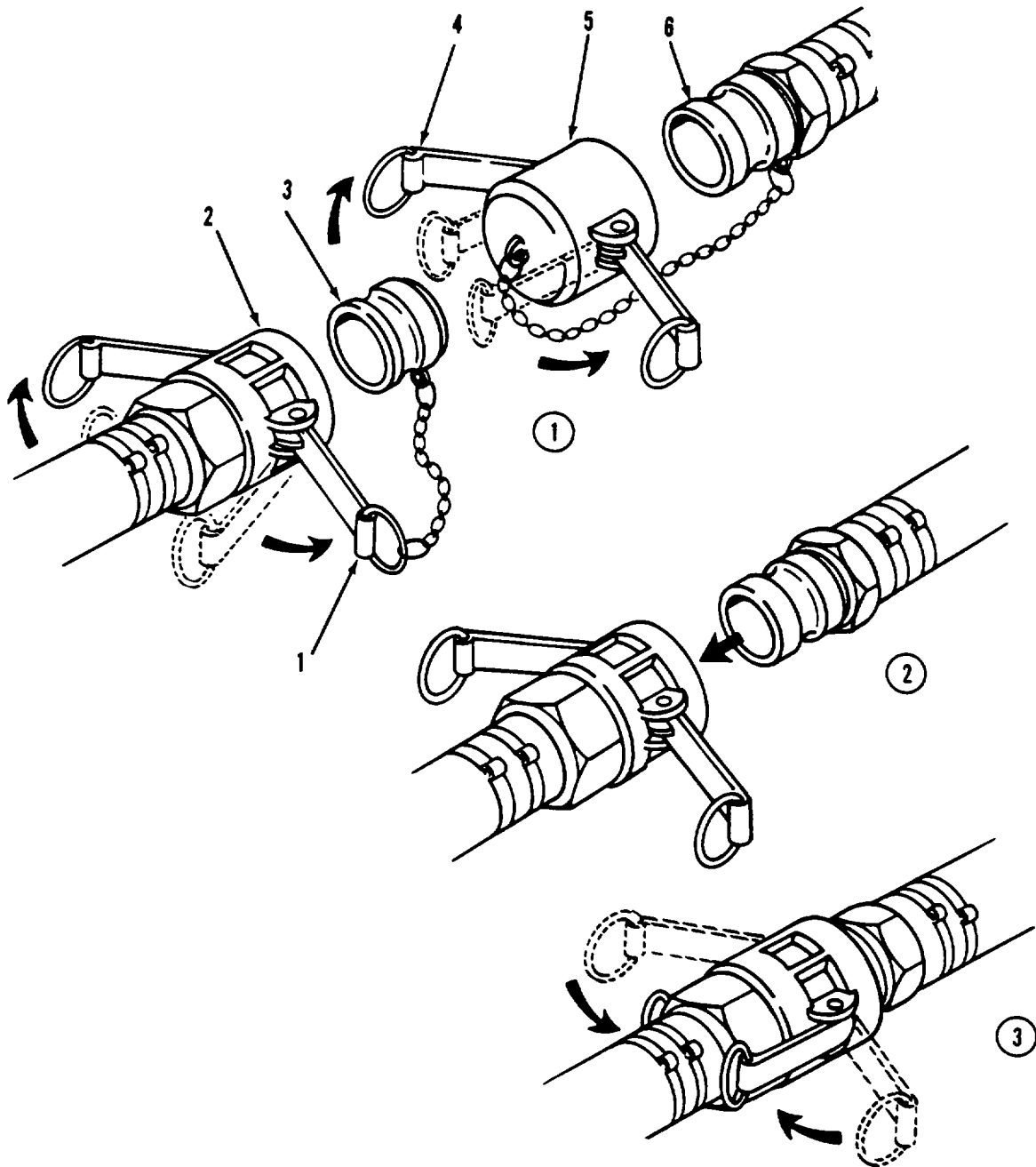

Figure 2-12. Quick Disconnect Couplings.

2-11. ASSEMBLY AND PREPARATION FOR USE - cont.*Disconnection***WARNING**

Do not disconnect hose couplings while water system is pressurized. Hose ends may whip, causing injury to personnel and damage to equipment.

- (8) Pull locking arms (1) up and out from female coupling (2).
- (9) Pull female couplings (2) from male couplings (6).
- (10) Insert plug (3) in female coupling (2) and pull locking arms (1) back against coupling body.
- (11) Place cap (4) over male coupling (6) and pull locking arms (5) back against cap body.

e Connection of Coupling Clamps.

The TW DS hoseline and pumping station components are equipped with grooved pipe couplings. These components must be connected using hinged, boltless, coupling clamps. The coupling clamps consist of a one-piece hinged housing, gasket and locking pin. An assembly tool, hammer, and punch are required for installation and removal of the clamps. The following instructions apply to all coupling clamp removal and installation tasks.

WARNING

- To prevent contamination of water system and damage to the equipment, use care when installing coupling clamps to avoid getting dirt, sand and debris on mating surfaces or in hoses.
- To prevent leaks and ensure water-tight connections, make sure gaskets are installed properly.

To prevent contamination of water system, do not use petroleum based lubricants on coupling gaskets.

Installation. Refer to figure 2-13.

- (1) If installed, remove protective caps from ends of hoses (1 and 2).
- (2) Apply a thin, even coating of lubricant (Item 3, App E) to coupling gasket (3).
- (3) Slide gasket (3) over end of pipe coupling (2).

NOTE

To aid installation, blocks of wood (4x 4x 6 inches) of similar material may be placed under hose ends to help support and aline pipe couplings.

- (4) Aline and mate ends of pipe couplings (1 and 2).
- (5) Slide coupling gasket (3) between ends of pipe couplings (1 and 2) Make sure gasket is not seated in coupling grooves.

2-11. ASSEMBLY AND PREPARATION FOR USE - cont.

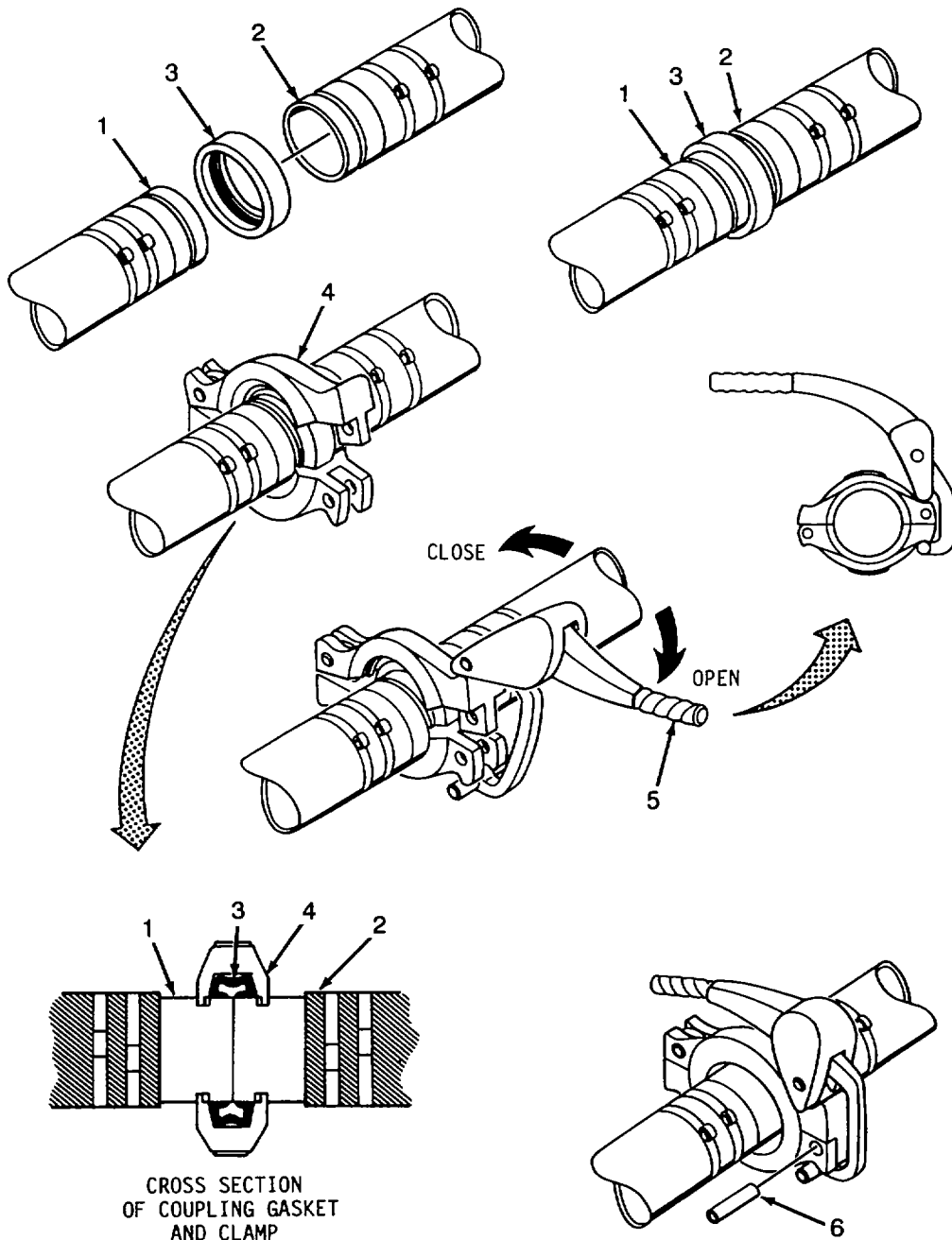

Figure 2-13. Coupling Clamps Installation.

2-11. ASSEMBLY AND PREPARATION FOR USE - cont.

- (6) Position one half of coupling clamp (4) over coupling gasket (3) and into grooves of both pipe couplings (1 and 2).
- (7) Close other half of coupling clamp (4) over coupling gasket (3) while alining clamp with grooves of both pipe couplings (1 and 2) Hold clamp in place.
- (8) Position assembly tool (5) on coupling clamp (4) as shown.
- (9) Push handle of assembly tool (5) toward coupling clamp (4). As clamp is squeezed together, make sure coupling gasket is not pinched between clamp and pipe couplings (1 and 2). Assembly tool handle will lock in closed position when clamp is correctly seated in grooves of pipe couplings.

NOTE

Locking pin must be installed with splines (ridges) pointing out from coupling clamp.

- (10) Using a hammer, drive locking pin (6) through locking pin holes in both halves of coupling clamp (4) Make sure locking pin is sticking through both halves of clamp.
- (11) Pull handle of assembly tool (5) away from coupling clamp (4) and remove tool.

Removal Refer to figure 2-14.

- (12) Position assembly tool (5) on coupling clamp (4) and push tool handle toward coupling clamp (5).

WARNING

To prevent injury to personnel and damage to the equipment, all water pumps must be shutdown, water pressure relieved from discharge hoses and appropriate valves closed before removing coupling clamps.

- (13) Using a punch and hammer, drive out locking pin (6) from coupling clamp (4).
- (14) Pull handle of assembly tool (5) away from coupling clamp (4) and remove tool.
- (15) Open and remove coupling clamp (4) from pipe coupling (1 and 2).
- (16) Separate pipe couplings (1 and 2) and remove coupling gasket (3).
- (17) Install protective covers over over ends of hoses and components.

2-11. ASSEMBLY AND PREPARATION FOR USE - cont.

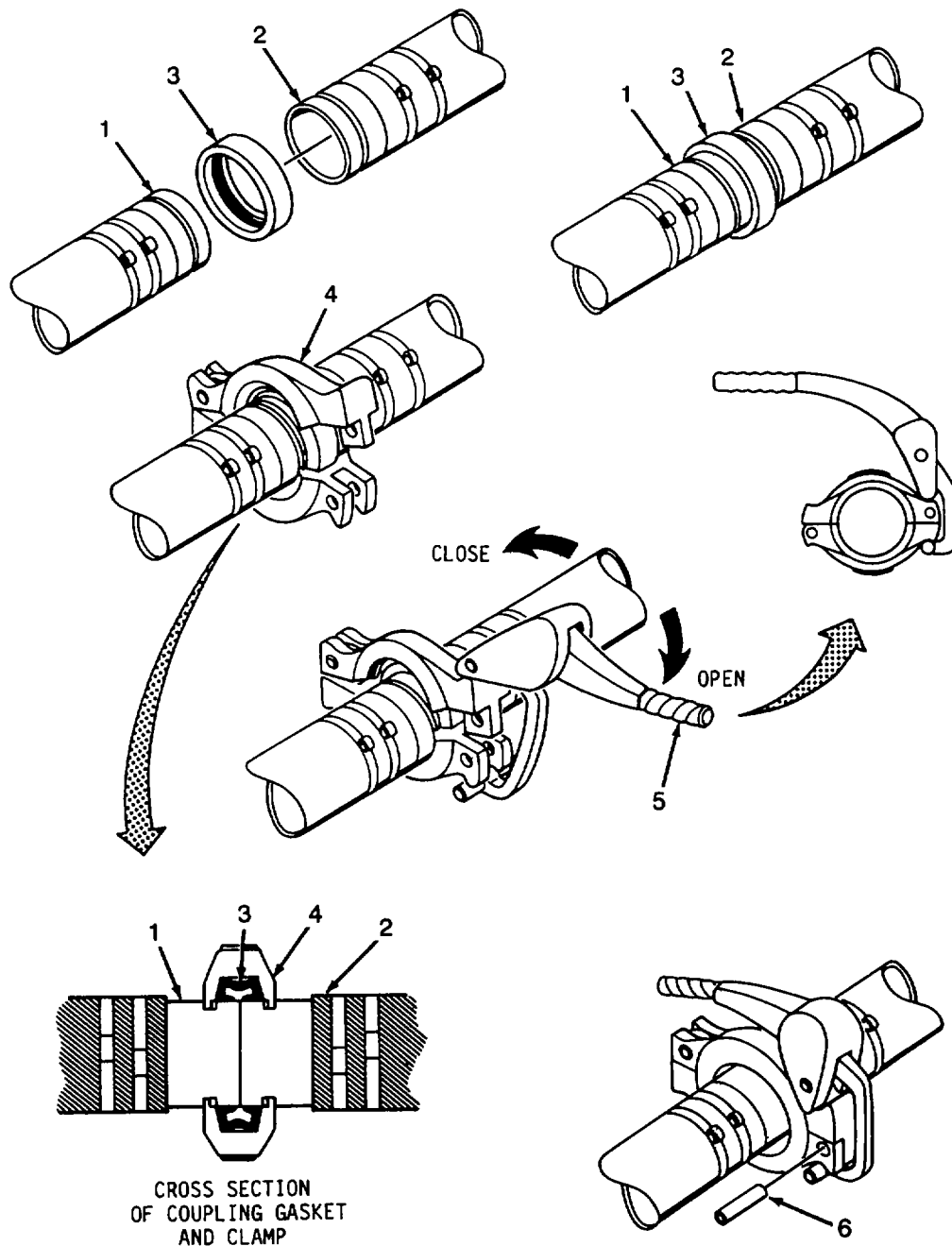

Figure 2-14. Coupling Clamps Removal.

2-11. ASSEMBLY AND PREPARATION FOR USE - cont.

- f. Assemble Lead Pumping Station. Refer to figure 2-15.

WARNING

To prevent contamination of water system and damage to components, keep rocks, dirt, mud, sand and debris from entering open couplings and hoses during assembly.

NOTES

Refer to para 2-11d to connect quick disconnect couplings.
Refer to para 2-11e to install coupling clamps.

- (1) Assemble and prepare 600 gpm pump for use Refer to the applicable TM.
- (2) Position 600 gpm pump so that suction port is pointing toward water source.

Suction Line

- (3) Connect butterfly valve (10) to suction port on 600 gpm pump with coupling clamp (9).

NOTE

Ensure that anti-seize tape is applied in the same direction as the threads.

- (4) If required, apply antiseize tape (Item 4, App E) to male threads of coupling pipe fitting (12) and screw fitting into coupling half (13). Connect assembled parts to butterfly valve (10) with coupling clamp (11).

NOTE

Connect sufficient quantity of suction hoses to reach water source.

- (5) Connect 6-inch x 10-foot suction hose (14) to coupling half(13).
- (6) Connect reducing wye (15) to the last 6-inch x 10 foot suction hose (14).
- (7) Connect reducing wye (15) to 4-inch hose from water source.

Discharge Line

- (8) Connect check valve (2) to discharge port on 600 gpm pump with coupling clamp (1). Arrow on side of valve must point away from pump.

WARNING

To prevent injury to personnel, open port of pressure relief valve must point away from water pump.

- (9) Connect pressure relief valve (4) to check valve (2) with coupling clamp (3).

2-11. ASSEMBLY AND PREPARATION FOR USE - cont.

- (10) Connect 6-inch x 20-foot discharge hose (6) to pressure relief valve(4) with coupling clamp (5).
- (11) Connect butterfly valve (8) to 6-inch x 20-foot discharge hose (6) with coupling clamp (7).

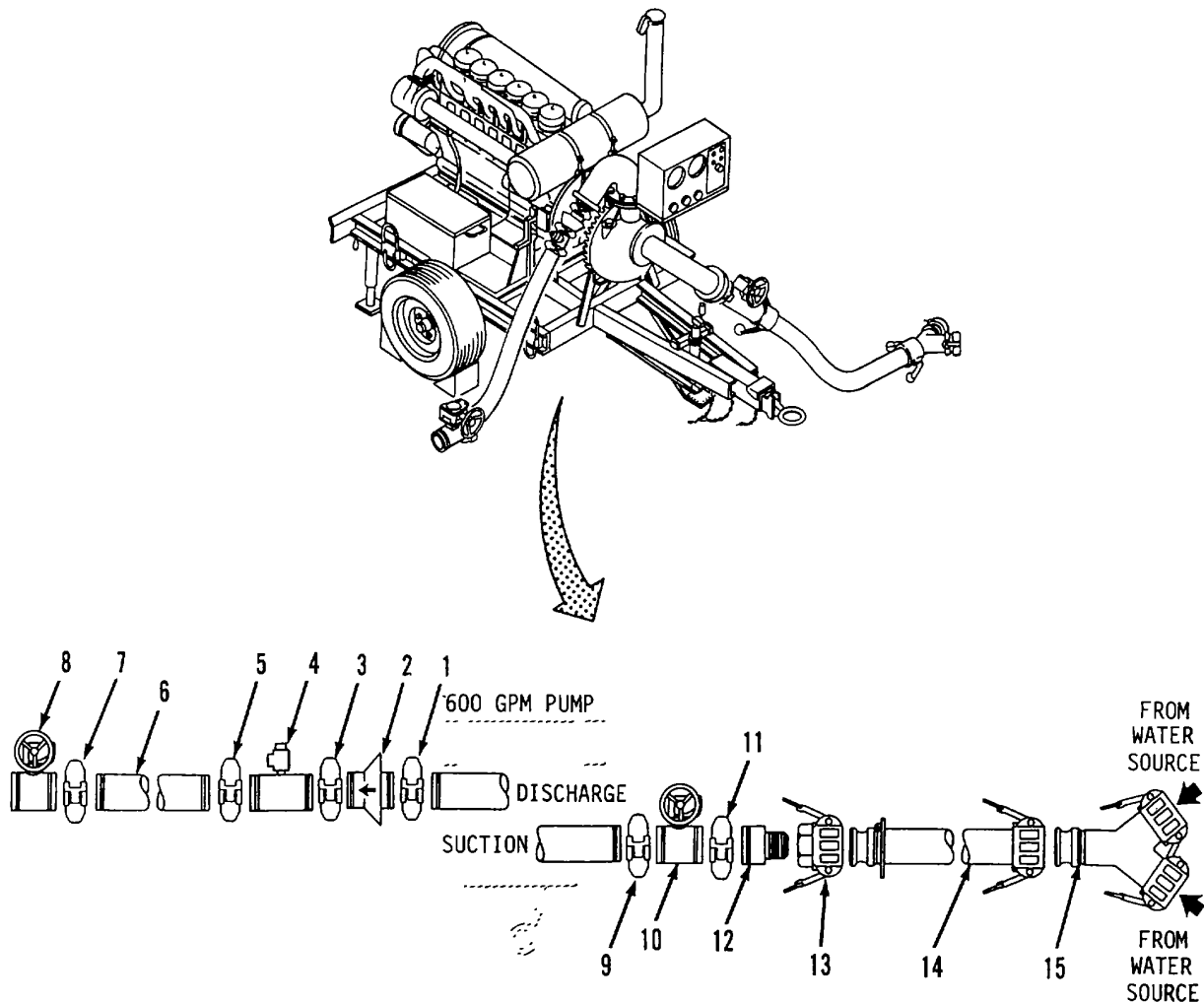

Figure 2-15. Lead Pumping Station Assembly.

2-11. ASSEMBLY AND PREPARATION FOR USE - cont.

g Assemble Boost Pumping Stations. Refer to figure 2-16.

WARNING

To prevent contamination of water system and damage to components, keep rocks, dirt, mud, sand and debris from entering open couplings and hoses during assembly

NOTES

- Assembly of one boost pumping station is shown. Assembly of three remaining boost pumping stations is similar.
- The TWDS Is supplied with six 600 gpm pumps. Only five pumps are used during normal operation. The sixth pump is kept as a spare.
- All components used to assemble the pumping stations are 6-inch diameter.
- Refer to paragraph 2-11e to install coupling clamps.

- (1) Assemble and prepare 600 gpm pump for use. Refer to the applicable TM.
- (2) Position 600 gpm pump so that suction port is pointing upline to the water source.

Suction Line.

- (3) Connect 6-inch x 10-foot discharge hose (12) to suction port on 600 gpm pump with coupling clamp (11).
- (4) Connect butterfly valve (14) to 6-inch x 10-foot discharge hose (12) with coupling clamp (13).
- (5) Connect lateral pipe fitting (wye) (16) to butterfly valve (14) with coupling clamp (15).

Discharge Line.

- (6) Connect check valve (2) to discharge port on 600 gpm pump with coupling clamp (1). Arrow on side of valve must point away from pump.

WARNING

To prevent injury to personnel, open port of pressure relief valve must point away from water pump.

- (7) Connect pressure relief valve (4) to check valve (2) with coupling clamp (3).
- (8) Connect 6-inch x 20-foot discharge hose (6) to pressure relief valve (4) with coupling clamp (5).
- (9) Connect butterfly valve (8) to 6-inch x 20-foot discharge hose (6) with coupling clamp (7).
- (10) Connect lateral pipe fitting (wye) (10) to butterfly valve (8) with coupling clamp (9).

2-11. ASSEMBLY AND PREPARATION FOR USE - cont.

Bypass Line.

- (11) Connect butterfly valve (18) to lateral pipe fitting (wye) (16) with coupling clamp (17).
- (12) Connect 6-inch x 50-foot discharge hose (20) to butterfly valve (18) with coupling clamp (19).
- (13) Connect other end of 6-inch x 50-foot discharge hose (20) to lateral pipe fitting (wye) (10) with coupling clamp (21).
- (14) Repeat steps (1) through (13) for four remaining boost pumping stations.

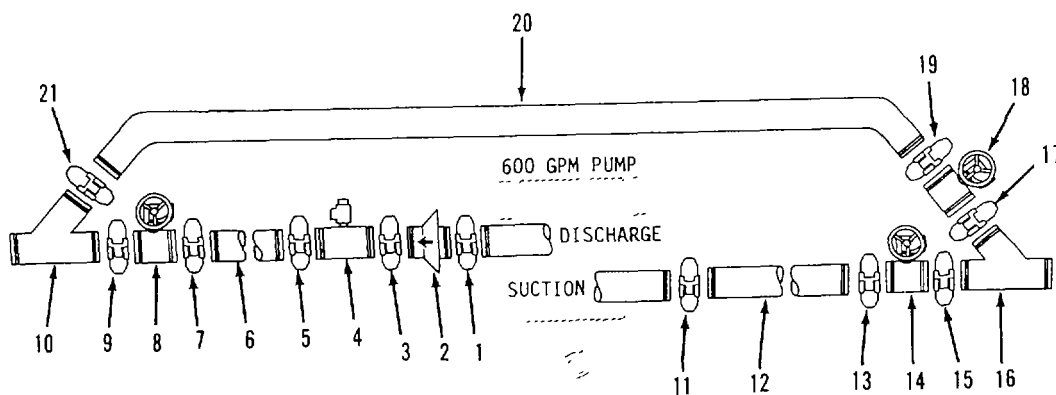
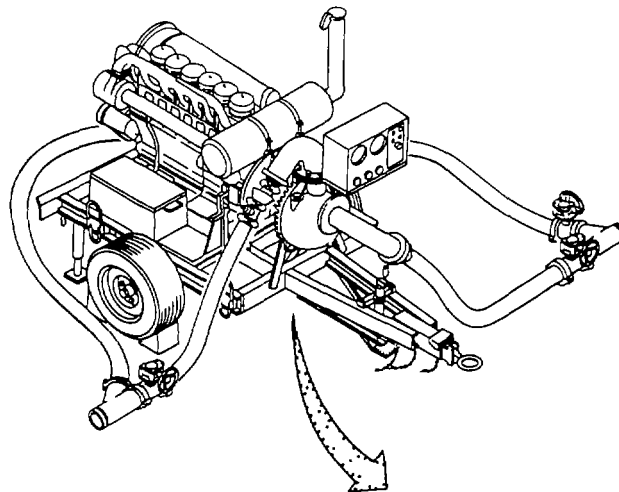

Figure 2-16. Boost Pumping Station Assembly.

2-11. ASSEMBLY AND PREPARATION FOR USE - cont.h. Lay Hoseline (Flaking Box Assemblies)*General.*

- (1) Hoses required to assemble the 10-mile hoseline are stowed in 64 flaking boxes. Each flaking box contains two 6-inch x 500 foot discharge hoses joined by a coupling clamp. Installation of the full 10-mile segment will require deployment of all flaking boxes. Use enough hoseline to provide slack so that connections to pumping stations and storage assemblies can be made easily.
- (2) A maximum of four flaking boxes may be loaded onto a 2-1/2 ton cargo truck. Flaking boxes can be loaded onto the truck using a forklift or they may be hoisted using the lifting sling supplied with the system.

Crew Requirements Refer to figure 2-17.

- (3) A minimum of two cargo trucks with crews of five men each is recommended for hose laying operations. Crews alternate between laying hose and reloading trucks. Task assignments for each crew-member are as follows.
 - (a) Supervisor. One supervisor is required per truck to over-see hose laying operations.
 - (b) Driver. One driver is needed to operate each cargo truck.
 - (c) Assistant Driver. An assistant driver is required to observe hose laying operation and direct driver to speed up, slow down, or stop depending on line walkers laying hose line.
 - (d) Linewalkers. A minimum of two linewalkers are needed to follow behind each truck straightening out kinks or bends in the hoseline, removing obstructions in the hose route, positioning hoseline away from the roadway and installing hoseline swivels. Installation of suspension assemblies and road crossing guards may require additional personnel.

2-11. ASSEMBLY AND PREPARATION FOR USE - cont.

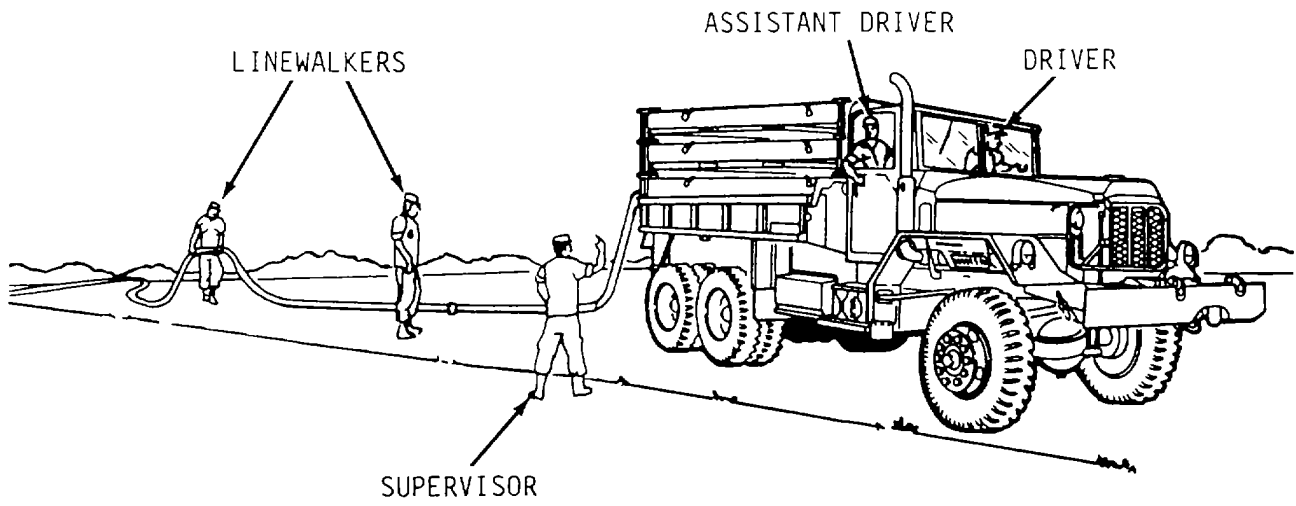

Figure 2-17. Crew Requirements.

2-11. ASSEMBLY AND PREPARATION FOR USE - cont.

Stack Flaking Boxes Refer to figure 2-18.

WARNINGS

- To prevent injury to personnel and damage to equipment, make sure stacked flaking boxes are properly aligned and nested before removing lifting sling.
- Stand clear of load being lifted in case of lift sling or hoist failure.
- Do not exceed capacity of lifting device. Lifting device must have a minimum capacity of 16,000 pounds.
- Do not stack or hoist flaking boxes more than four high.

CAUTION

Lifting sling hooks must point outward to prevent damage to sides of flaking box.

NOTE

Make sure flaking boxes are stacked with all tailgates at the same end.

- (4) Connect lifting sling (1) to four lifting shackles (2) on sides of flaking box (3).
- (5) Carefully lift flaking box (3) and lower onto top of flaking box (4). Make sure legs of upper flaking box (3) are properly aligned and nested in frame of lower flaking box (4), then remove lifting sling (1).
- (6) Repeat step (5) until flaking boxes are stacked four high.
- (7) Connect lifting sling (1) to four lifting shackles (2) on flaking box (5) at bottom of stack.

WARNINGS

- To prevent injury to personnel and damage to equipment, make sure stacked flaking boxes are properly aligned and nested before hoisting onto truck.
- Do not load flaking boxes in excess of truck capacity.

NOTE

Make sure flaking boxes are stacked with tailgates (removable ends) to rear of cargo truck.

- (8) Carefully hoist stacked flaking boxes onto bed of cargo truck.
- (9) Disconnect lifting sling (1) from bottom flaking box (5).

WARNING

To prevent injury to personnel and damage to equipment, all flaking boxes must be securely fastened to cargo truck. Climbing a steep grade may cause flaking boxes to shift and fall from truck.

- (10) Using lifting shackles (2), secure all flaking boxes to cargo truck to prevent movement during hose laying operations.

2-11. ASSEMBLY AND PREPARATION FOR USE - cont.

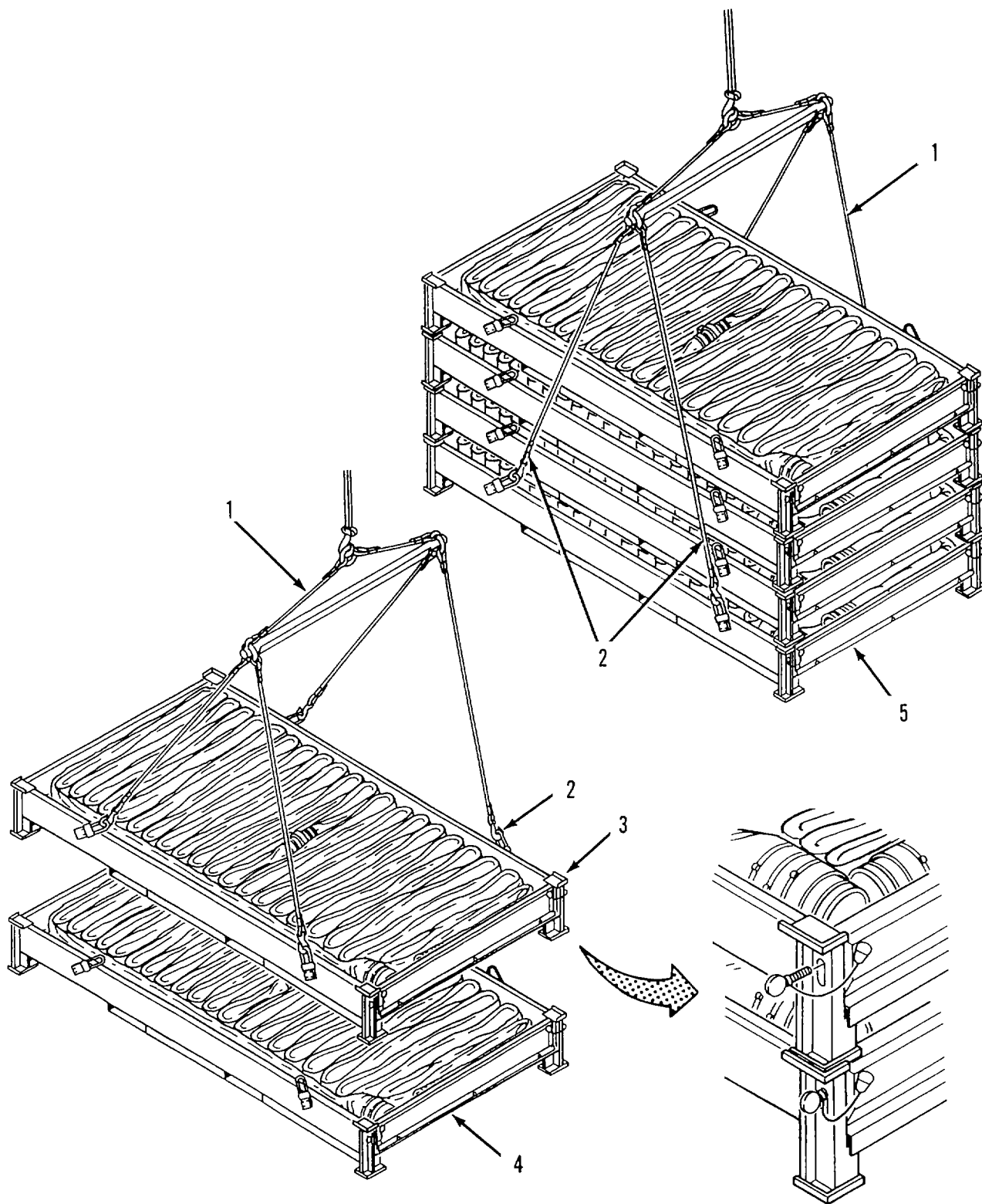

Figure 2-18. Stacking Flaking Boxes.

2-11. ASSEMBLY AND PREPARATION FOR USE - cont.

Install Breakaways Refer to figure 2-19.

NOTE

Hoseline should be deployed from the top flaking box, down Tailgate. should be left in place on lower flaking boxes until hose is ready to be deployed.

- (11) Loose two thumbscrews (1) on side of flaking box (2).
- (12) Lift up on tailgate (3), then pivot tailgate out away from flaking box (2.)
- (13) Pull about three feet of of hose (4) (leading end) from flaking box.
- (14) Position breakaway between tailgate (3) and folded hose (4) in flaking box (2).
- (15) Hang top of breakaway (5) on studs (6) in top of tailgate.
- (16) Position openings in bottom of breakaway (5) over studs (7) on flaking box (2).

CAUTION

Wires securing breakaways to flaking boxes must pull free during hose laying operations Do not wrap wires more than one time around studs.

- (17) Secure breakaway (5) to studs (6 and 7) with three wires (8) as shown. Wires must be able to pull free during hose laying operation.
- (18) Repeat steps (11) through (17) for remaining flaking boxes.

2-11. ASSEMBLY AND PREPARATION FOR USE- cont.

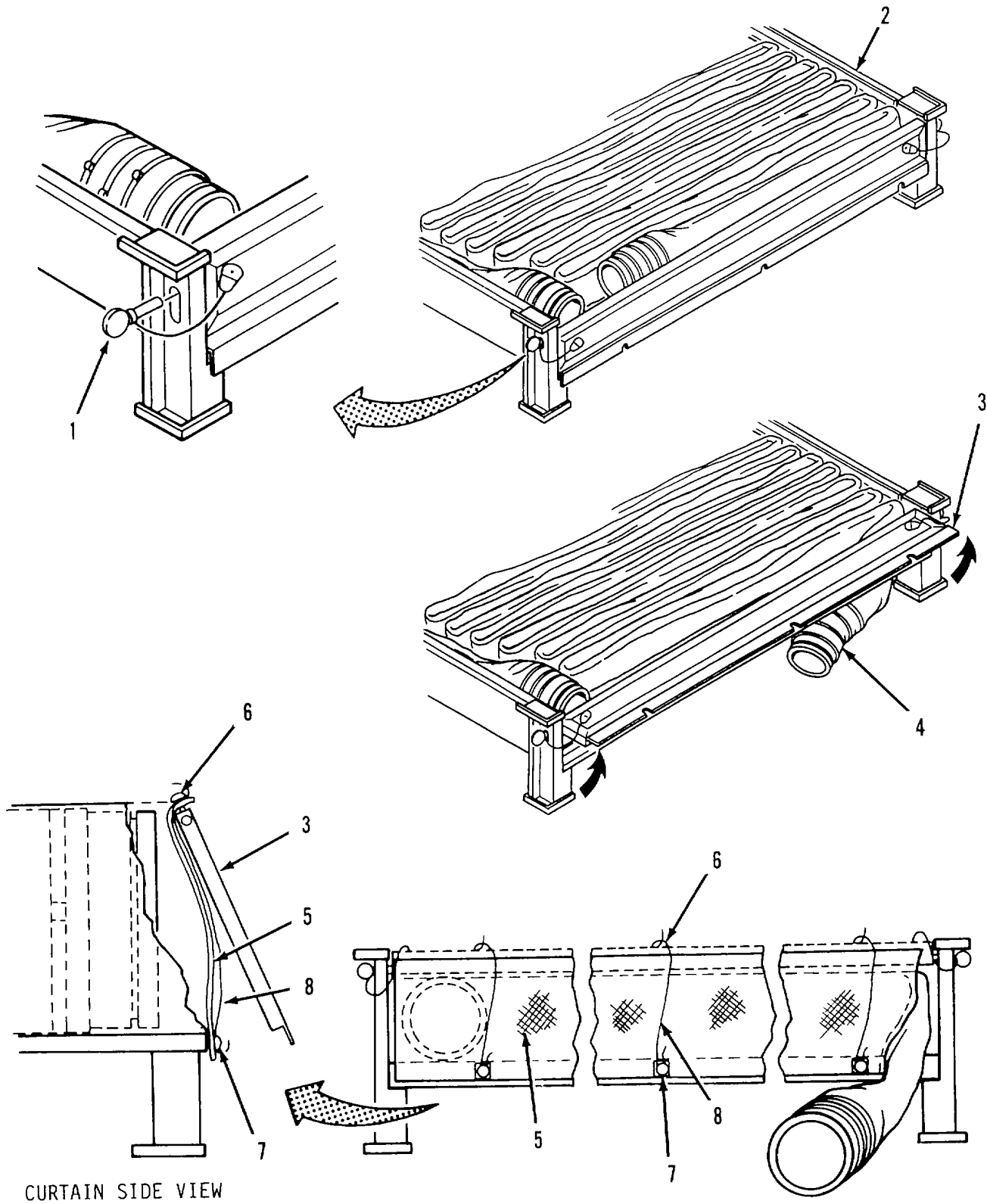

Figure 2-19. Breakaway Installation.

2-11. ASSEMBLY ANI) PREPIARATION FOR USE - cont.

Install Swivels Refer to figure 2-20.

WARNING

To prevent system contamination, protect hose ends and coupling clamps from sand, dirt and debris.

CAUTION

To prevent damage to the equipment, a swivel joint must be installed every 1,000 feet to prevent damage caused by twisting and rolling of hose when system is pressurized.

NOTES

- • Remove caps or packaging material from ends of hose as required.
 - • One coupling clamp is supplied on trailing end of hose, the other is supplied with the swivel joint.
- (19) Remove coupling clamps (4) from leading ends of hoses (1, 6, 8, and 10) in flaking boxes 1 through 4.
 - (20) Connect swivel (3) to leading end of hose (1) in flaking box No 4 with coupling clamp (5) Connect other end of swivel to trailing end of hose (2) in flaking box No 3 with coupling clamp (4).
 - (21) Connect swivel (3) to leading end of hose (6) in flaking box No 3 with coupling clamp (5) Connect other end of swivel to trailing end of hose (7) in flaking box No 2 with coupling clamp (4).
 - (22) Connect swivel (3) to leading end of hose (8) in flaking box No 2 with coupling clamp (5) Connect other end of swivel to trailing end of hose (9) In flaking box No. 1 with coupling clamp (4).
 - (23) Connect swivel (3) to trailing end of hose (11) with coupling clamp (4).

2-11. ASSEMBLY AND PREPARATION FOR USE - cont.

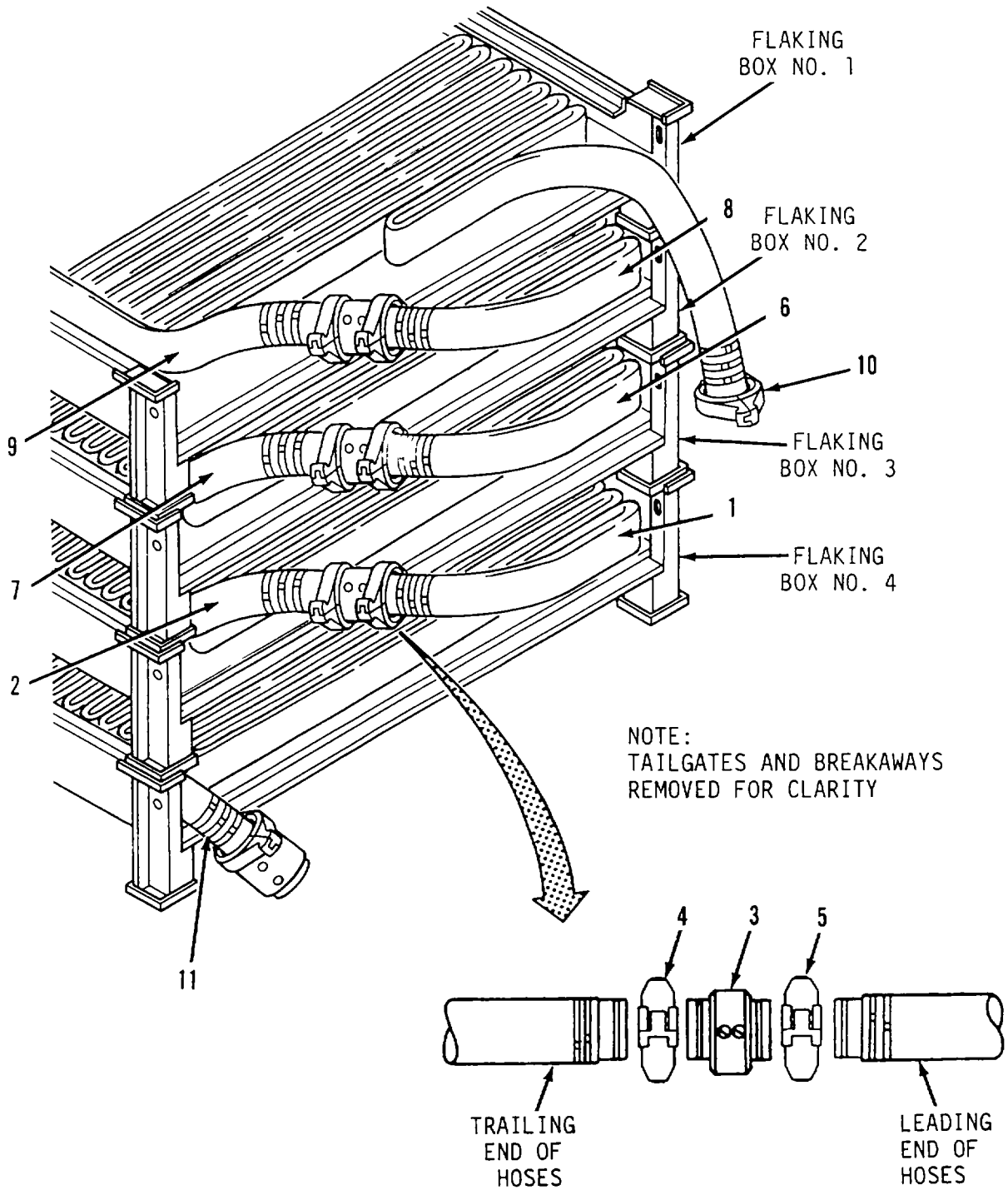

Figure 2-20. Swivel Installation

2-11. ASSEMBLY AND PREPARATION FOR USE - cont.

Lay Hoseline (Lead Pump Station to First Boost Pumping Station) Refer to figure 2-21.

- (24) Manually pull about 50 feet of hose (1) from top of flaking box (2) and position on ground. Weight of hose will now hold line in place.
- (25) Connect end of hose (1) to butterfly valve (5) on lead pumping station discharge hose (6) with coupling clamp (4).

NOTE

The recommended hose laying speed is about 10 mph. The best speed for any installation will depend on the type of terrain, manpower available and experience of the installation crew.

- (26) Start movement of cargo truck (3) along installation route.

CAUTIONS

- Contraction of hose during startup will damage equipment if slack is not provided in hoseline. Hose segments should be snaked slightly to allow at least 3 feet of slack for each hose length (500 feet).
 - If hose is being installed along a roadway, position hose clear of traffic areas.
- (27) As the cargo truck (3) moves forward, hose (1) will pull itself from flaking box (2). Linewalkers must remove bends, twists, kinks and tangles from hoseline as it is deployed. Continue to lay hose until trailing end is pulled from bottom flaking box.

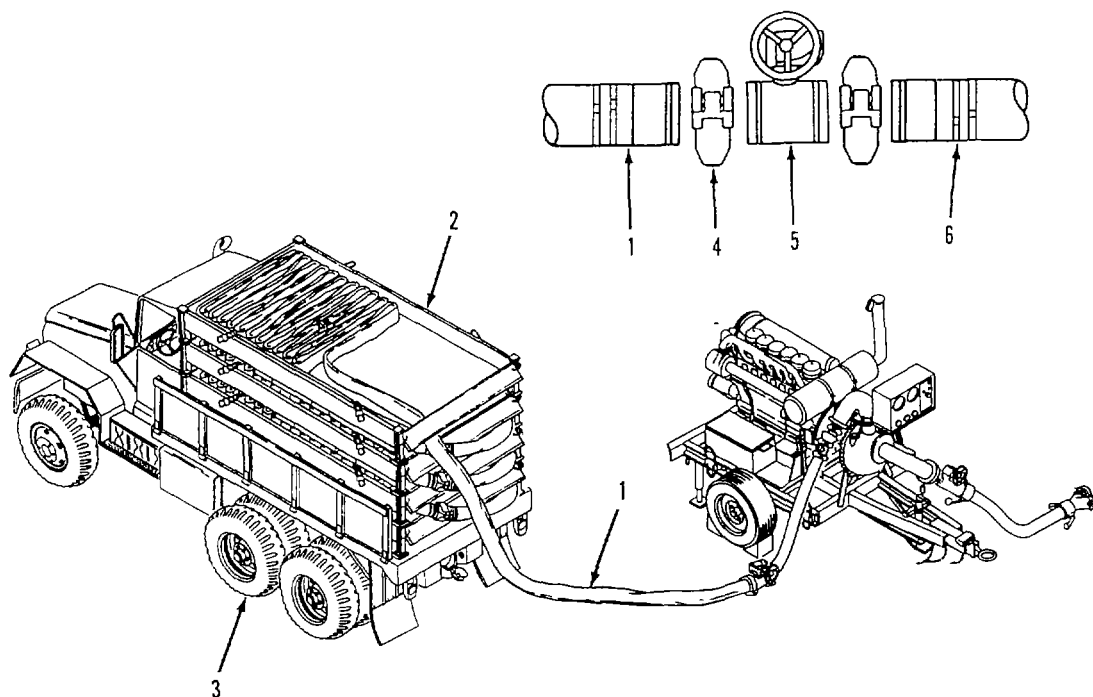

Figure 2-21. Laying Hoseline

2-11. ASSEMBLY AND PREPARATION FOR USE - cont.**NOTE**

Keep empty flaking boxes and tailgates for reuse.

- (28) Repeat steps (4) through (27), except step (25) until enough hose has been deployed to reach next downline boost pumping station. Make sure swivel joints are installed every 1,000 feet. As required, refer to para 2- 11h and 2-11i to install roadway crossing guards and suspension kits along installation route.

Connect Boost Pumping Stations. Refer to figure 2-22.

NOTE

As each boost pumping station is reached, snake hose as required to take up slack in hose.

- (29) As each boost pumping station is reached, connect trailing end of deployed hose (1) to suction lateral fitting (3) with coupling clamp (2).
- (30) Connect leading end of flaked hose (4) to discharge lateral fitting (6) of boost pumping station with coupling clamp (5). Continue laying hose to next boost pumping station.
- (31) Repeat steps (29) through (31) until all boost pumping stations are connected to the hoseline.

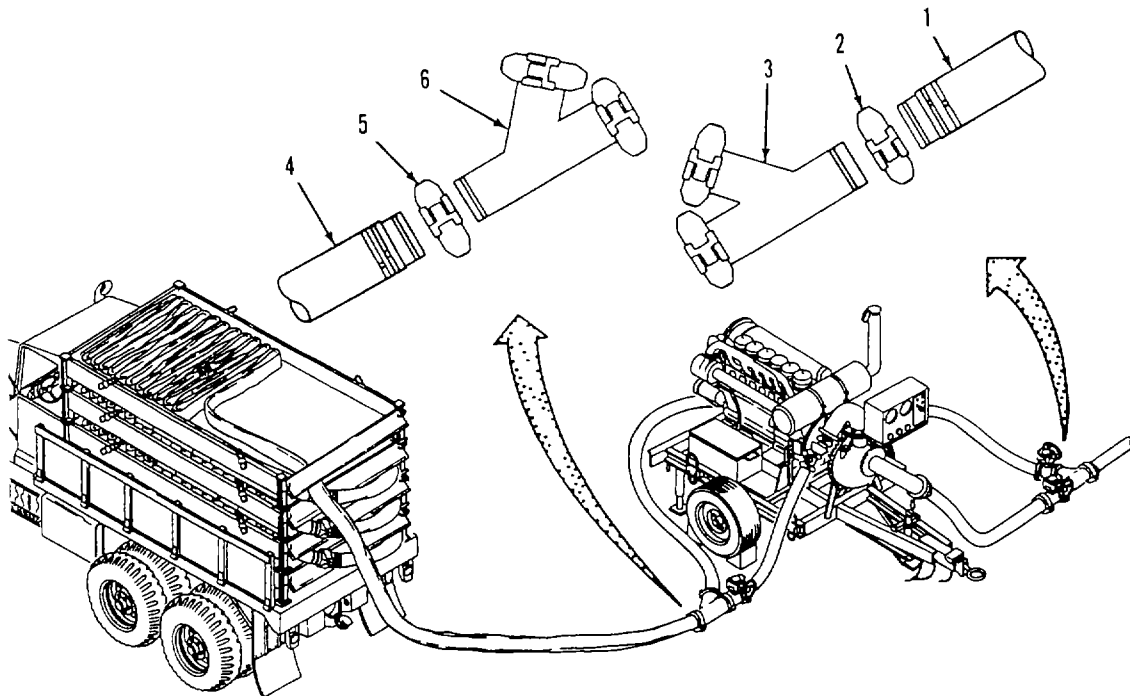

Figure 2-22. Boost Pumping Station Connection

2-11. ASSEMBLY AND PREPARATION FOR USE - cont.

- i. Install Pressure Reducing Valve. Refer to figure 2-23 Installation of the pressure reducing valve in the hoseline must be determined by reviewing the site survey and 600 gpm pump performance data (refer to applicable TM). The valve is installed when pressure at a certain point in the hoseline is expected to exceed 225 psi. If the hoseline crosses over a steep hill or ridge, a pressure reducing valve is normally required on the downhill side of the hoseline route.

NOTE

Refer to para 2-11e to remove and install coupling clamps.

- (1) Locate hoseline coupling clamp nearest to pressure reducing valve installation point.
- (2) Remove coupling clamp (3) and open hoseline at two 6-inch x 500 feet discharge hoses (4 and 6).
- (3) Connect pressure relief valve (2) to inlet side of pressure reducing valve (7) with coupling clamp (1).
- (4) Connect upline 6 inch x 500 feet discharge hose (4) to pressure relief valve (2) with coupling clamp (3).
- (5) Connect downline 6 inch x 500 feet discharge hose (6) to pressure reducing valve (7) with coupling clamp (5).
- (6) Set isolation valves to open position (para 2-6).

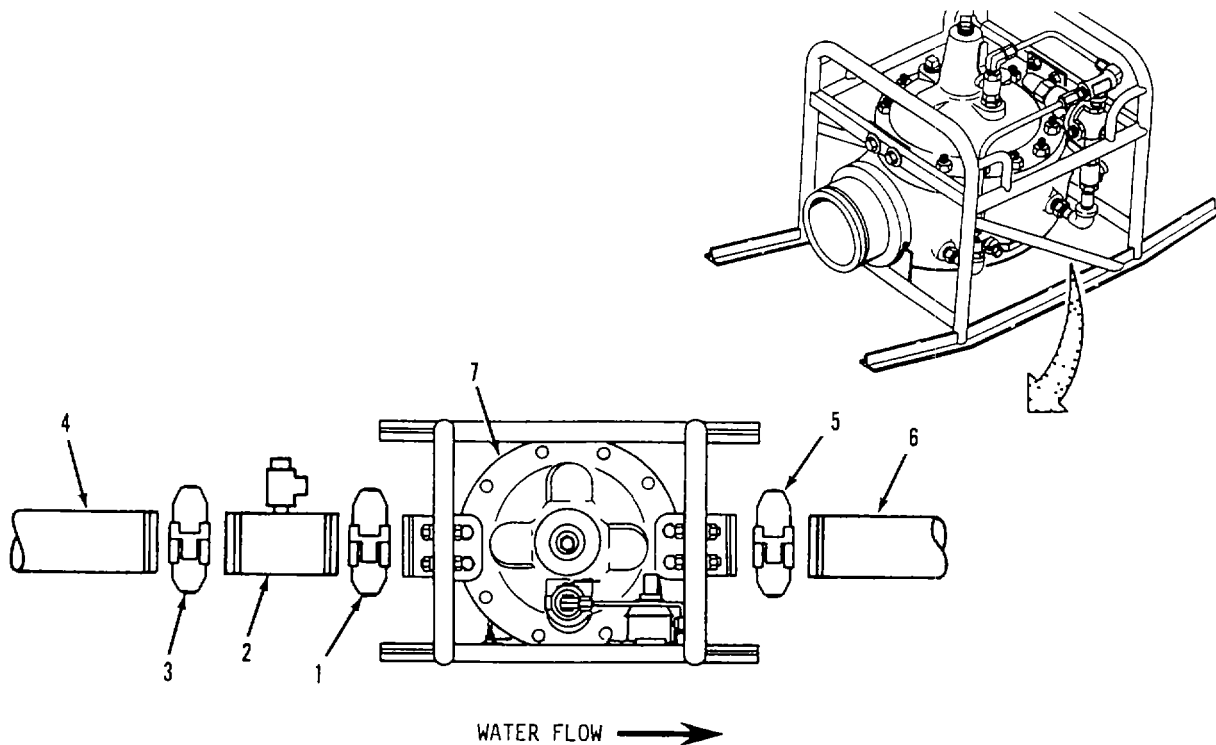

Figure 2-23. Pressure Reducing Valve Installation

2-11. ASSEMBLY AND PREPARATION FOR USE - cont.

- J. Assemble Hose Suspension Kits. Hose suspension kits are required to lift the hoseline above obstacles such as streams, rivers, gullies or ravines. Each kit contains the tools and materials needed to cross a span of up to 150 feet. Location of the hose suspension ~~is~~ along the hoseline route must be determined from the initial site survey

Assemble Tripods Refer to figure 2-24.

- (1) Using available materials and manila rope (2) from suspension kit, construct two tripods (1), one on each side of obstacle to be crossed. Tripods must be strong enough to support filled hoseline and tall enough to keep hose above rising water and obstructions. Install additional supports on tripods as required.
- (2) Using driving head (3) and hammer, drive two anchor stakes (4) into ground about 15 feet from each tripod (1). Anchors must be in line with, and leaning away from, both tripods as shown. Anchors should extend about 6-inches above ground when fully installed.
- (3) Hang one tackle block (5) beneath each tripod (1).
- (4) Thread end of wire rope (6) through pulley on tackle block (5) on near side of obstruction.
- (5) Pull wire rope (6) across obstruction and through tackle block (5) on far side of obstruction.

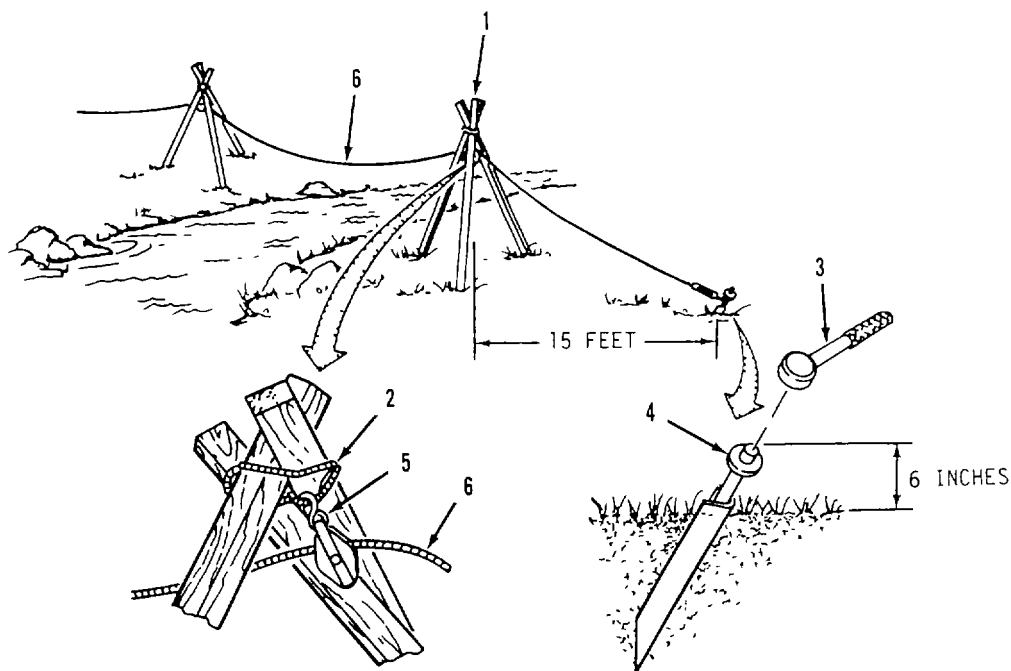

Figure 2-24. Tripod Assembly

2-11. ASSEMBLY AND PREPARATION FOR USE- cont.

Assemble Wire Rope and Turnbuckles. Refer to figure 2-25.

- (6) Using two clamps from suspension kit, make a loop in end of wire rope as follows.
 - (a) Remove nuts (1 and 4) and clamps (2 and 5) from U-bolts (3 and 6).
 - (b) Bend end of wire rope (7) to form a loop (tag end of rope should be about 9-inches long). Position thimble (8) in loop and hold in place.
 - (c) Place U-bolt (3) over doubled end of wire rope (7), about 1/2-inch from thimble (8) Install clamp (2) and two nuts (1) on U-bolt Tighten nuts securely.
 - (d) Place second U-bolt (6) over doubled end of wire rope (7), about 4-inches down from first U-bolt (3) Install clamp (5) and two nuts (4) on U-bolt. Tighten nuts securely.

CAUTION

To prevent damage to threads of turnbuckle when tension is applied, at least two threads of hook bolts must be exposed inside turnbuckle body when fully extended.

- (7) Unscrew turnbuckle (9) until it is fully extended.
- (8) Connect hook on turnbuckle (9) to stake (10).
- (9) Connect loop in wire rope (7) to hook on other end of turnbuckle (9).
- (10) Repeat steps (6) through (11) for opposite end of wire rope (7)
- (11) Tighten both turnbuckles (9) until wire rope (7) is taut (with no load).

2-11. ASSEMBLY AND PREPARATION FOR USE - cont.

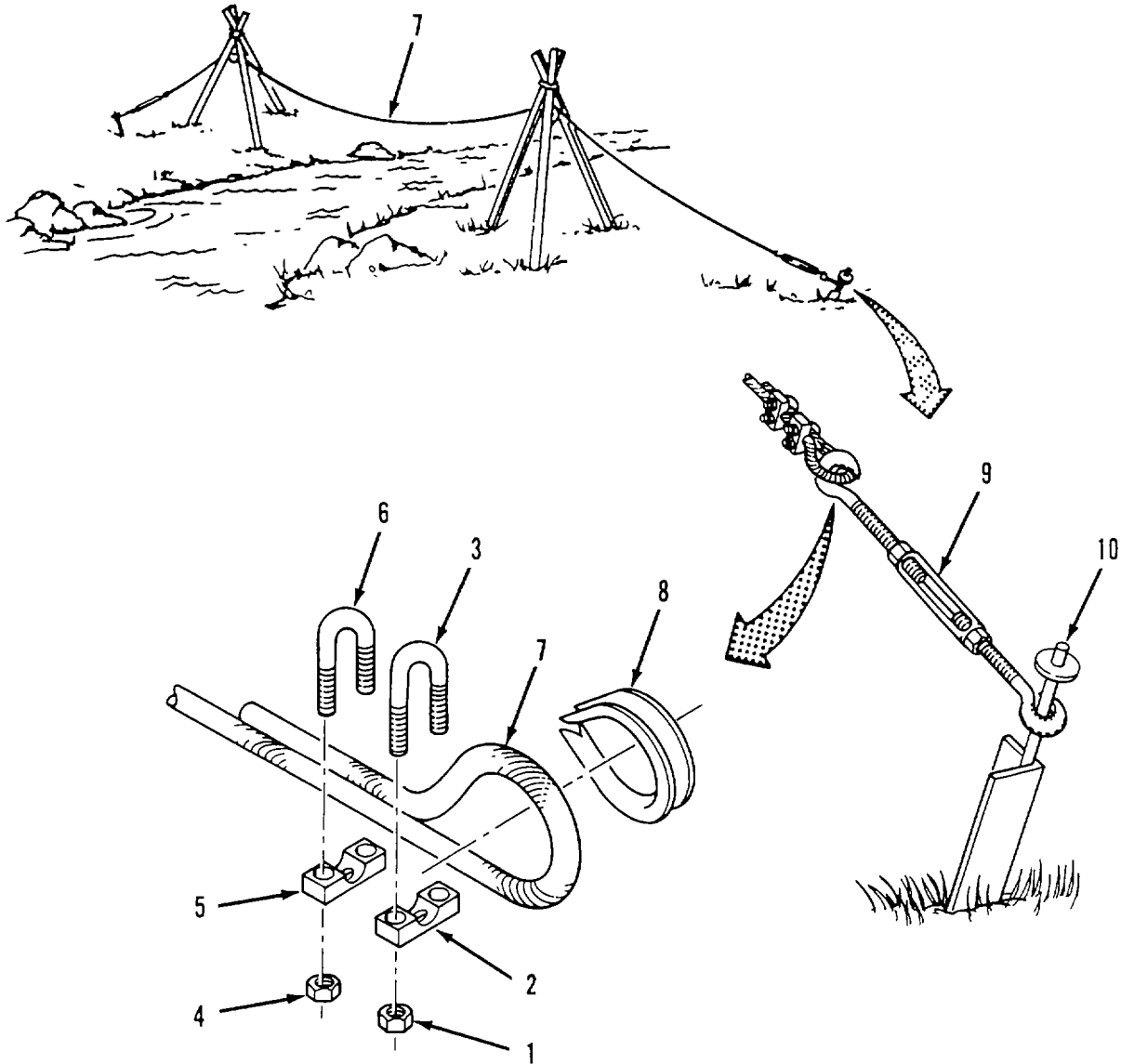

Figure 2-25. Wire Rope and Turnbuckle Assembly

2-11. ASSEMBLY AND PREPARATION FOR USE - cont.

Suspending Hoseline. Refer to figure 2-26.

- (12) Tie manila rope (1), supplied in suspension kit, to leading end of hose (2) Make sure rope is long enough to cross obstacle.
- (13) Hang shackle (4) on wire rope (3).
- (14) Position saddle (5) around hose (2).
- (15) Lift hose (2) and attached saddle (5) up to shackle (4) Secure saddle to shackle with bolt (6).

CAUTION

To prevent damage to hose and provide correct support, saddles must be installed along hose at five feet intervals.

- (16) Using manila rope (1), start pulling hose (2) out along wire rope (3). At five feet intervals, stop pulling hose and install additional saddles (5) as described in steps (13), (14), and (15). Repeat until hose is fully suspended across obstacle.

NOTE

Saddles and shackles at both ends of hose must be secured to wire rope with u-bolt clamps to prevent slack from developing in middle of span. Clamps must be installed on the span side of the shackles.

- (17) When hose (2) is fully suspended, secure shackles (4) at both ends of suspended hose to wire rope (3) with three u-bolt clamps (7).

2-11. ASSEMBLY AND PREPARATION FOR USE - cont.

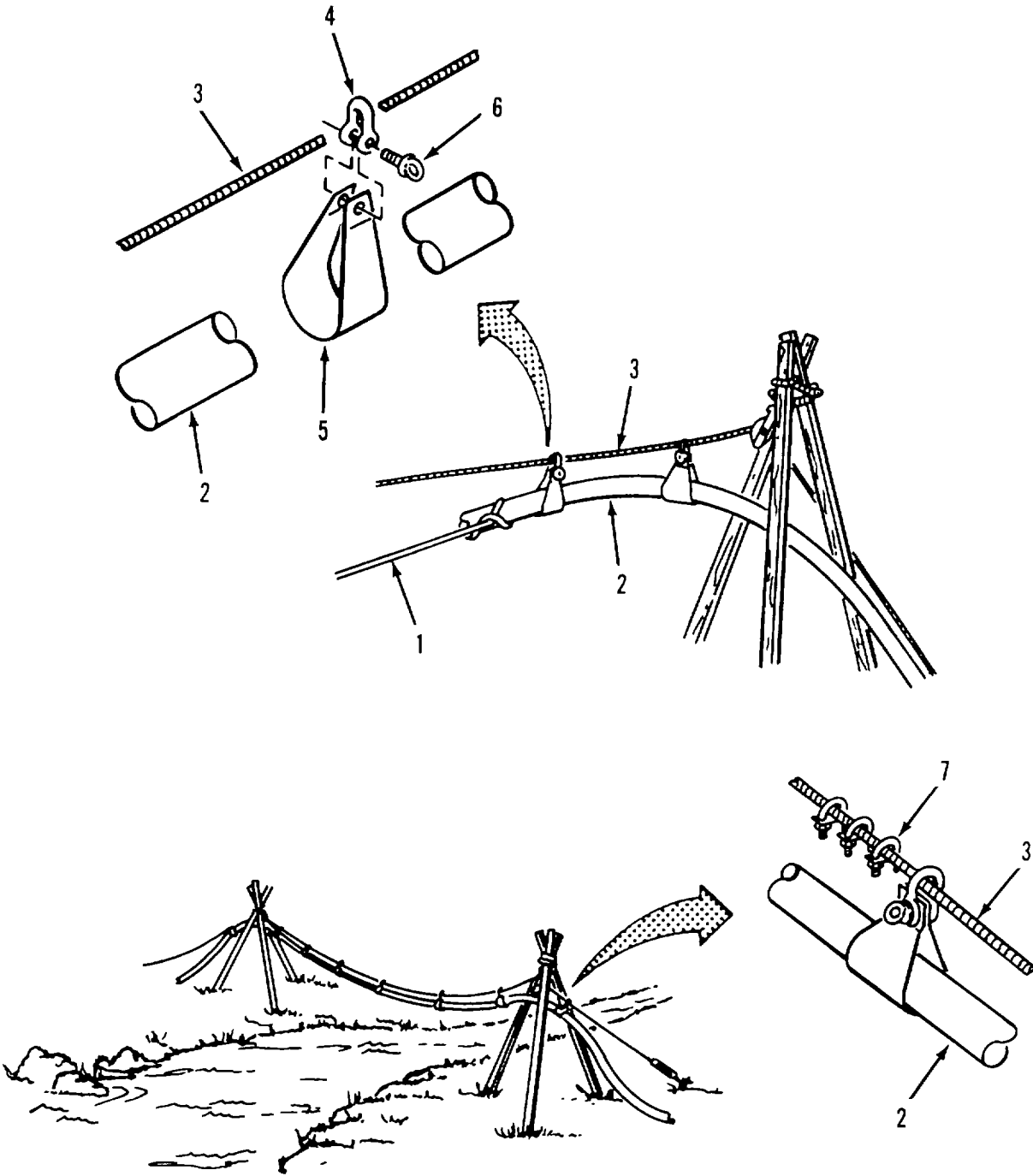

Figure 2-26. Suspending Hoseline

2-11. ASSEMBLY AND PREPARATION FOR USE - cont.

- k. Install Roadway Crossing Guards. Refer to figure 2-27. If hoseline must be laid across a roadway or railway, hose should be laid under existing bridge or through a culvert pipe where possible. Hoseline must never be buried unprotected because compacting earth may collapse hose and shifting rocks, sand and soil will gradually damage hose. If hoseline must cross a railway, dig a tunnel beneath gravel of railbed and nail a plank to bottom of roadway crossing guard. Location of the roadway crossing guards along the hoseline route must be determined from the initial site survey

- (1) Dig a trench (1) about 18 inches deep and 18 inches wide across road or railbed.

CAUTION

Remove stones and sharp rocks from trench before laying hose. Rocks can cause hose damage and failure.

- (2) If hose (2) is being run under a railroad bed, install planking (3) in tunnel before laying hose. Planking may also be used in roadway crossings to provide additional protection to hose.

- (3) Lay hose (2) in trench (1).

CAUTIONS

- Roadway crossing guards are 5-feet long. Guards must cover hose the full width of roadway and should extend about 2-feet from each side of roadway.
- To prevent damage to hose, avoid sharp bends in hose where hose enters crossing guard.

- (4) Place roadway crossing guards (4) over hose (2). If planks (3) have been installed, nail crossing guards to planks.

- (5) Backfill trench (1) using dirt removed in step (1). Do not put any stones on top of roadway crossing guard (4). Fill trench one to two inches above original roadbed to allow for compacting of soil.

2-11. ASSEMBLY AND PREPARATION FOR USE - cont.

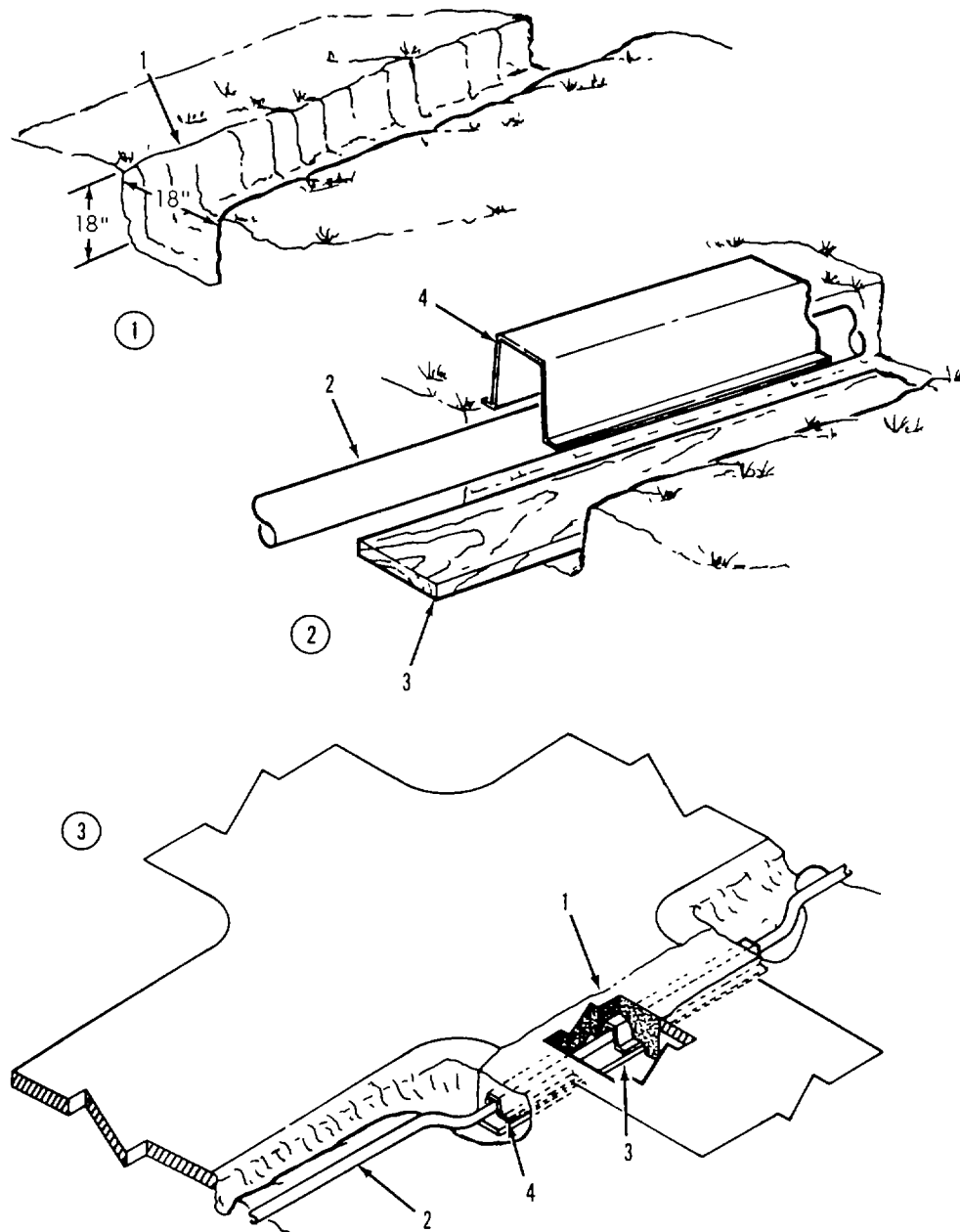

Figure 2-27. Roadway crossing Guard Installation

2-11. ASSEMBLY AND PREPARATION FOR USE - cont.

1. Assemble Storage Assembly Refer to figure 2-28.

NOTES

- One 6-inch coupling clamp is supplied with the storage assembly, the other clamp is part of the hoseline.
 - Refer to para 2-11e to install and remove coupling clamps.
- (1) Prepare and assemble 20K collapsible tank (14) for use Refer to applicable TM.
 - (2) Locate hoseline coupling clamp nearest to storage assembly installation site. Remove coupling clamp (4) and open hoseline at two 6-inch x 500 feet discharge hoses (3 and 5)
 - (3) Connect reducer tee (1) to 6-inch x 500 feet discharge hose (3) with coupling clamp (2).
 - (4) Connect 6-inch x 500 feet discharge hose (5) to reducer tee (1) with coupling clamp (4).
 - (5) Connect adapter (7) to reducer tee (1) with 4-inch coupling clamp (6).

NOTE

Refer to para 2-1 1d to connect quick disconnect couplings.

- (6) Connect 4-inch gate valve (8) to adapter (7).
- (7) Connect water meter (9) to 4-inch gate valve (8).
- (8) Connect four 4-inch x 10 feet suction hoses (10, 11, 12 and 13) to water meter (9).
- (9) Connect 4-inch x 10 feet suction hose (13) to female elbow (14) (inlet) on 20K collapsible tank (15).

2-11. ASSEMBLY AND PREPARATION FOR USE-cont.

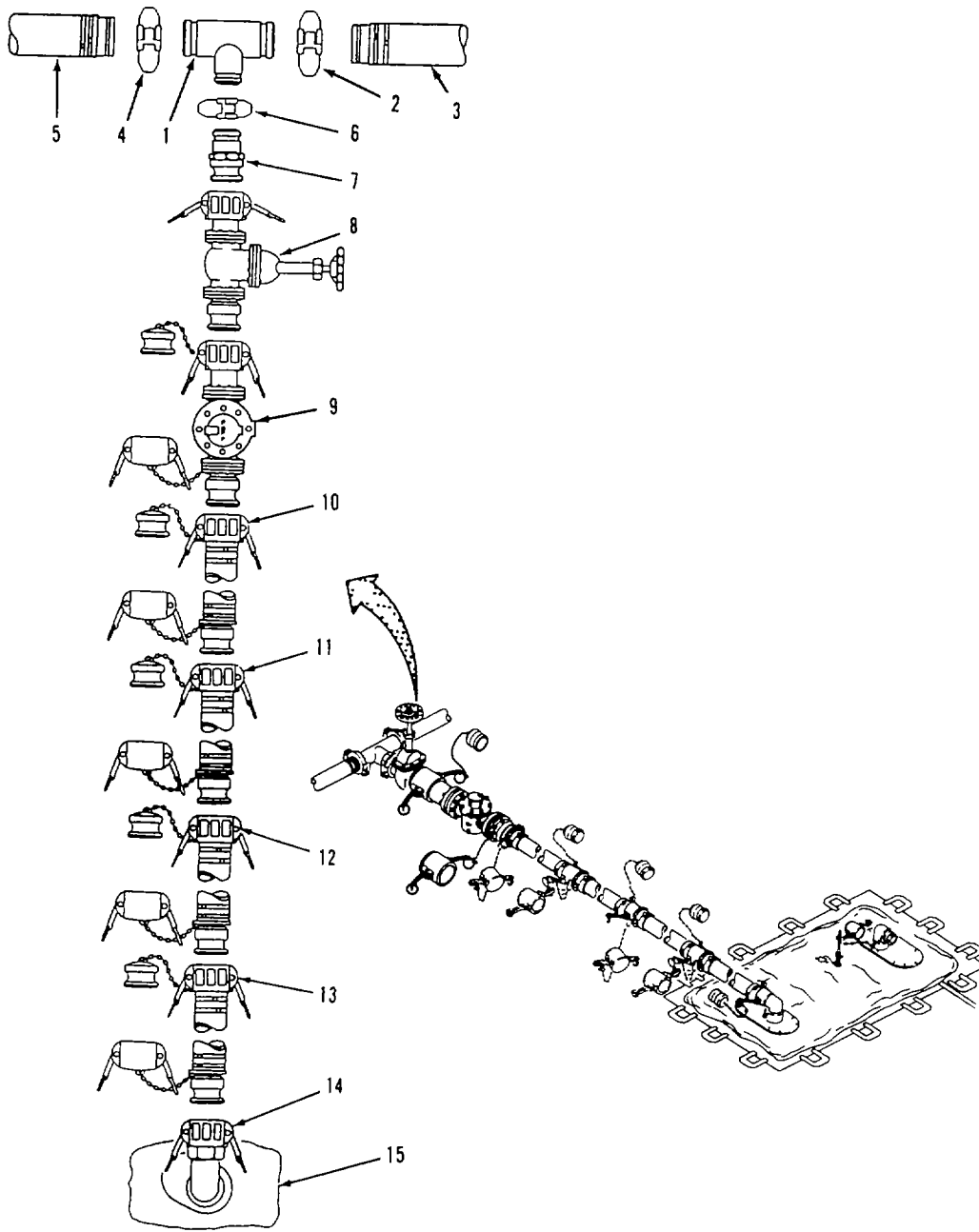

Figure 2-28. Storage Assembly Installation

2-11. ASSEMBLY AND PREPARATION FOR USE-cont.

m. Assemble Distribution Points. Refer to figure 2-29.

WARNING

To prevent contamination of drinking water, make sure protective caps and plugs are installed when components are not in use. Do not remove caps and plugs from components until couplings are ready to be connected.

NOTES

- Assembly of one distribution point is shown, the other is similar.
 - Refer to para 2-11d to connect quick disconnect couplings.
- (1) Connect 4 inch female x 2 inch male adapter (2) to male discharge elbow(1) on 20K collapsible fabric tank.
 - (2) Connect 2 inch x 10 feet suction hose (3) to 4 inch female x 2 inch male adapter (2).
 - (3) Position 125 gpm pump (4) in distribution point. Assemble and prepare 125 gpm pump (4) for use (refer to the applicable TM).
 - (4) Connect 2 inch x 10 feet suction hose (3) to suction (inlet) port on 125 gpm pump (4).
 - (5) Connect 2 inch x 10 feet discharge hose (5) to discharge (outlet) port on 125 gpm pump (4).
 - (6) Position hypochlorination unit (7) in distribution point. Assemble and prepare hypochlorination unit (7) for use (refer to the applicable TM).

NOTE

Use of adapters for connecting the hypochlorination unit will be determined by the type equipment supplied with your system. Adapters may not be required.

- (7) If required, connect 2 inch female x 1 1/2 inch male adapter (6) to inlet port of hypochlorination unit (7). Connect 1 1/2 inch female x 2 inch male adapter (8) to outlet port of hypochlorination unit (7).
- (8) Connect end of 2 inch x 10 feet discharge hose (5) to adapter (6).
- (9) Connect 2 inch x 20 feet discharge hose (9) to adapter (8), if installed. If adapter is not installed, connect hose to outlet port of hypochlorination unit (7).
- (10) Connect Y-fitting (10) to 2 inch x 20 feet discharge hose (9).
- (11) Connect 2 inch gate valve assembly (11) to Y-fitting (10).
- (12) Connect 2 inch x 20 feet discharge hose (12) to 2 inch gate valve assembly (11).
- (13) Connect Y-fitting (13) to 2 inch x 20 feet discharge hose (12).

2-11. ASSEMBLY AND PREPARATION FOR USE-cont.

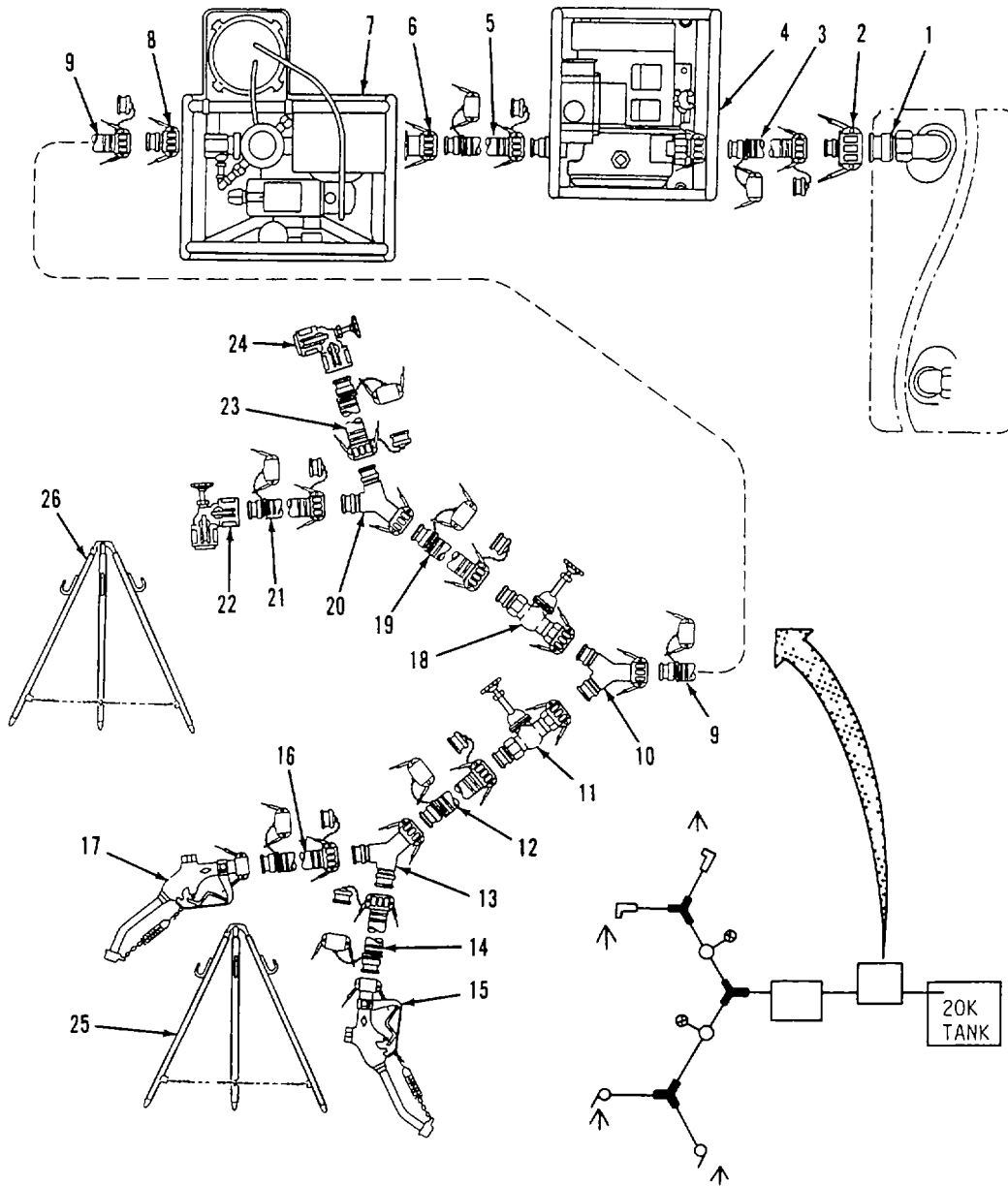

Figure 2-29. Distribution Point Assembly.

2-11. ASSEMBLY AND PREPARATION FOR USE-cont.

- (14) Connect 2 inch x 20 feet discharge hose (14) to Y-fitting (13).
- (15) Connect 1 1/2 inch distribution nozzle (15) to 2 inch x 20 feet discharge hose (14).
- (16) Connect 2 inch x 20 feet discharge hose (16) to Y-fitting (13).
- (17) Connect 1 1/2 inch distribution nozzle (17) to 2 inch x 20 feet discharge hose (16).
- (18) Unfold nozzle stand assembly (25) and hang 1 1/2 inch distribution nozzles (15 and 17) on stand.
- (19) Connect 2 inch gate valve assembly (18) to Y-fitting (10).
- (20) Connect 2 inch x 20 feet discharge hose (19) to 2 inch gate valve assembly (18).
- (21) Connect Y-fitting (20) to 2 inch x 20 feet discharge hose (19).
- (22) Connect 2 inch x 20 feet discharge hose (21) to Y-fitting (20).
- (23) Connect elbow valve (22) to 2 inch x 20 feet discharge hose (21).
- (24) Connect 2 inch x 20 feet discharge hose (23) to Y-fitting (20).
- (25) Connect elbow valve (24) to 2 inch x 20 feet discharge hose (23).
- (26) Unfold nozzle stand assembly (26) and hang elbow valves (22 and 24) on stand.

2-12. INITIAL ADJUSTMENT.a. Hoses, Couplings and Valves

- (1) Verify that all quick disconnect couplings in the storage and distribution kits are securely connected and locked.
- (2) Verify that caps and plugs are installed on all open tees, fittings and hoses.
- (3) Inspect all hoses for kinks. Straighten out kinks and tight bends.
- (4) Verify that all gate valves and butterfly valves are closed.

b. 600 Gpm Pumps. Perform initial adjustments in accordance with the applicable TM.c. 20K Collapsible Fabric Tanks. Perform initial adjustments in accordance with the applicable TM.d. 125 Gpm Pumps. Perform initial adjustments in accordance with the applicable TM.e. Hypochlorination Unit. Perform initial adjustments in accordance with the applicable TM.

2-13. OPERATING PROCEDURES.

- a. General. The primary function of the TWDS is to distribute water over a long distance to large water storage facilities such as the 300,000 and 800,000 Water Storage and Distribution Systems. Two storage and distribution kits, having a combined storage capacity of 40,000 gallons, are supplied with the TWDS and serve as auxiliary water distribution points. The TWDS has two primary modes of operation, fill and discharge. In the fill mode, water is drawn from the water source and pumped to the system and kits. During discharge, water is removed from the 20K tanks in the storage kits and pumped to consumers through the distribution points. The TWDS can operate in both fill and discharge modes at the same time.
- b. Fill Hoseline (Packing). Refer to figure 2-30. Before system startup, the hoseline must be filled with water to ensure priming of 600 gpm pumps and prevent damage to hoses from high winds. Filling (packing) of the hoseline is required when starting the system for the first time and after replacing or repairing a segment of the hoseline.

WARNINGS

- The water source must be tested and must meet water quality standards established by the office of the surgeon general
- Before packing hoseline, ensure that the product water meets the chlorine residual standard set by the office of the surgeon general. It is recommended that the chlorine residual of the water used to initially pack the line should be raised at least 5ppm over the standard set by the surgeon general to ensure proper disaffection of the TWDS. After the lines are packed, chlorine residual must be adjusted accordingly.

CAUTION

To prevent damage to the pumping stations, ensure sufficient water is available for packing the hoseline. Approximately 8,000 gallons are required to pack 1-mile of hoseline.

- (1) Disconnect last hoseline segment from downline water and distribution system. End of hoseline must remain open to allow initial flushing of sediment and contaminants from hoses.

CAUTION

Hoseline may be filled during system installation, as each boost pump is installed and brought on line, to reduce assembly and startup time and prevent damage to hoseline in the event of high winds.

- (2) Open suction valve L1 and discharge valve L2 at lead pumping station.
- (3) Open suction valves B2 and discharge valves B3 at all boost pumping stations.

2-13. OPERATING PROCEDURES-cont.

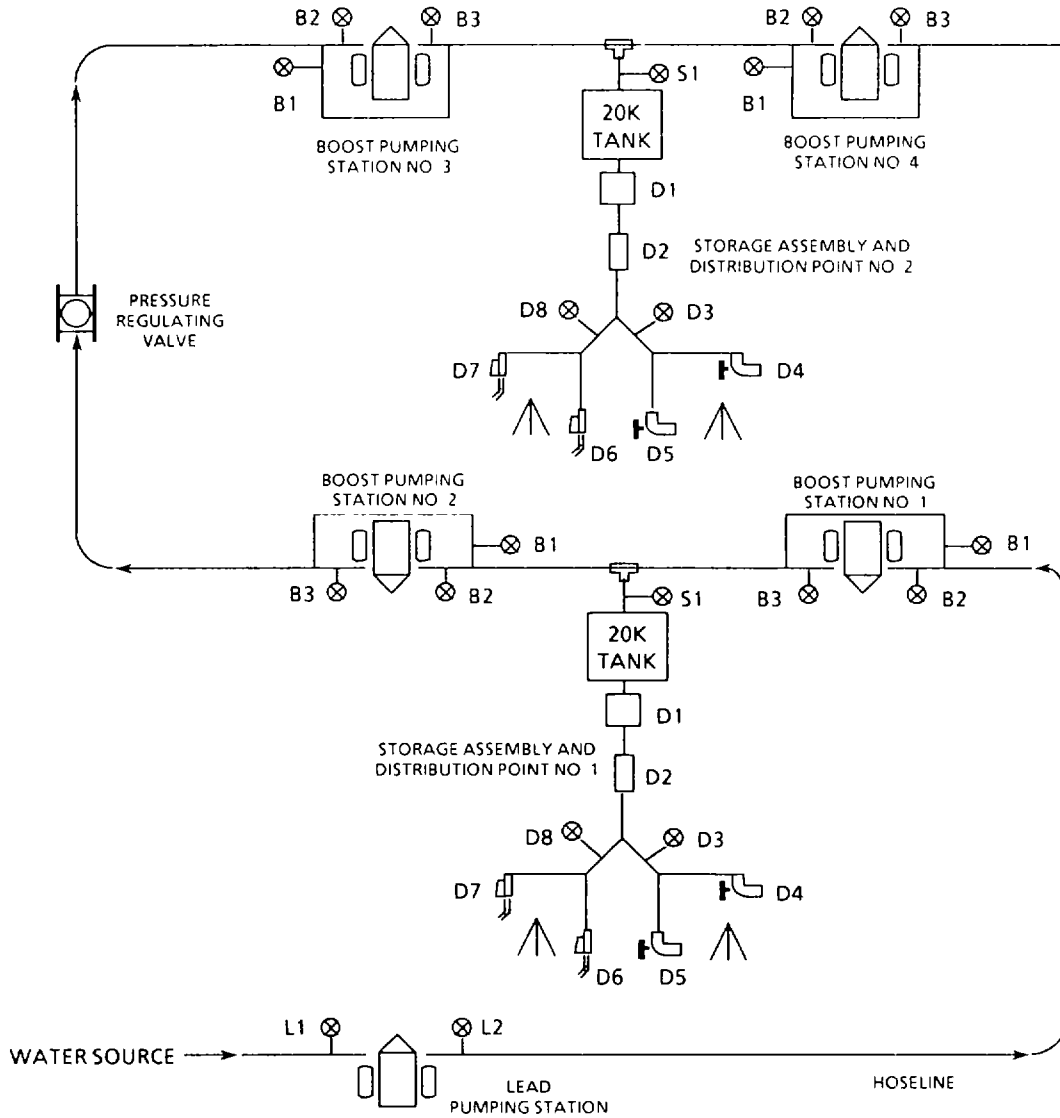

Figure 2-30. Water System Control Valves.

2-13. OPERATING PROCEDURES- cont.

- (4) Open air vent petcock on 600 gpm pump at all boost pumping stations (refer to the applicable TM)
Air trapped in hoseline must be vented as water moves downline to the boost pumps.

CAUTION

Lead pump must be operated in manual mode to prevent pressure variations and erratic operation of downline boost pumps

- (5) Start and operate 600 gpm pump at the lead pumping station (refer to applicable TM). Pump must be operated in manual mode
- (6) Watch hose for visual indication of approaching water at boost pumping station no 1. When air has vented and water flows from petcock, close petcock (refer to applicable TM).
- (7) Start and operate 600 gpm pump at boost pumping station no. 1 (refer to applicable TM). Boost pump may be operated in either manual or electric modes.
- (8) Repeat steps (6) and (7) for boost pumping stations no. 2, no. 3 and no. 4.

WARNING

To prevent injury to personnel and damage to the equipment, allow pumping stations to operate until dirt, sand and contaminants are flushed from system components before filling storage assemblies or connecting to water storage and distribution systems

- (9) Allow all pumps to operate until hoseline has been filled with water and contaminants are flushed from hoses, pumps and components.
- (10) When flushing is complete, shutdown 600 gpm pumps beginning with boost pumping station no 4, then boost pumping station no 3, no 2 and no 1 (refer to applicable TM). As each pump is shutdown, close suction valves B2 and discharge valves B3.
- (11) Shutdown 600 gpm pump at lead pumping station (refer to applicable TM).
- (12) Close suction valve L1 and discharge valve L2.
- (13) Reconnect hoseline to water storage and distribution system.

2-13. OPERATING PROCEDURES- cont.

c. Startup Refer to figure 2-30. Operation of the TWDS requires a minimum of seven operators. One operator is required for each pump station and one for each storage and distribution point. Operators must be in communication at all times.

- (1) If pressure regulating valve is installed, set three bypass control valve handles to open position (para 2-6).

WARNING

To prevent injury to personnel or damage to equipment, pump station and storage assembly operators must be in communication with each other during all phases of operation. Any unusual situations or difficulties must be reported immediately.

- (2) Open suction valve L1 and discharge valve L2 in lead pumping station.
- (3) Open suction valves B2 and discharge valves B3 in boost pumping stations.

CAUTION

Lead pump must be operated in manual mode to prevent pressure variations and erratic operation of downline boost pumps.

NOTE

Operator at lead pumping station must monitor status of advancing water column and system performance.

- (4) Start and operate 600 gpm pump in lead pumping station (refer to the applicable TM).
- (5) Start and operate 600 gpm pump in boost pumping stations (refer to the applicable TM).

NOTE

Running time and pumping rates will vary during operation depending on the amount of water being discharged and the storage capacity of the connected water systems.

- (6) During pump operation, monitor all pump stations for correct suction and discharge pressures in accordance with the applicable TM. Take corrective action if suction pressure is too low or discharge pressure is too high.

Fill mode

NOTE

- Storage and distribution point operators should notify pump station operators at beginning and end of tank filling operations
- Fill and discharge modes of storage assembly and distribution point no 1 is described. Operation of storage assembly and distribution point no. 2 is the same.

- (7) Open gate valve S1 at storage assembly and distribution point no 1.

2-13. OPERATING PROCEDURES- cont.

- (8) Allow water to flow into 20K tank until full (refer to applicable TM), then close gate valve S1.
- (9) Continue to operate pumping stations until downline water storage and distribution system is full.

Discharge Mode.

- (10) Determine chlorine residual and adjust chemical solution level in hypochlorination unit D2 as required Refer to the applicable TM.
- (11) If Installed, open discharge valve on 20K tank Refer to the applicable TM.
- (12) Start and operate 125 gpm pump D1 Refer to the applicable TM.
- (13) To dispense water though the elbow valves, proceed as follows
 - (a) Connect elbow valves D4 and D5 to water storage containers.
 - (b) Open discharge valve D3.
 - (c) Open elbow valves D4 and D5.
 - (d) When storage containers are full, close elbow valves D4 and D5 and disconnect from water storage containers.
 - (e) Close discharge valve D3
- (14) To dispense water through distribution nozzles, proceed as follows.
 - (a) Open discharge valve D8.
 - (b) Place distribution nozzles (D6 and D7) in water storage containers and squeeze control handles to dispense water.
 - (c) When water storage containers are full, release control handles on distribution nozzles.
 - (d) Close discharge valve D8.
- (15) When water discharge is complete, shutdown 125 gpm pump D1. Refer to the applicable TM).

2-13. OPERATING PROCEDURES- cont.

d Shutdown. Refer to figure 2-30/

- (1) Shutdown 600 gpm pumps in all boost pumping stations beginning with station no. 4, no. 3, no. 2, then no. 1. Refer to the applicable TM.
- (2) As boost pumps are shutdown, close discharge valves B3 to prevent back flow of water and loss of prime. Refer to applicable TM to shutdown pumps
- (3) Shutdown 600 gpm pump in lead pumping station. Refer to the applicable TM.
- (4) Close suction valve L1 and discharge valve L2 to prevent back flow of water.

2-14. DECALS AND INSTRUCTION PLATES.

Instruction plates are used on the TWDS to advise the operator of proper operating procedures. Stencils provide additional operating information and cautions to be observed during use of the equipment. Decals and instruction plates appear on major assemblies of the TWDS.

- a. 600 Gpm Pumps. For decals and instruction plates on the 600 gpm pumps, refer to the applicable TM.
- b. 125 Gpm Pumps. For decals and instruction plates on the 125 gpm pumps, refer to the applicable TM.
- c. 20K Collapsible Fabric Tanks. For decals and instruction plates on the 20K collapsible fabric tanks, refer to the applicable TM.
- d. Hypochlorination Unit. For decals and instruction plates on the hypochlorination units, refer to the applicable TM.
- e. Tricon. For decals and instruction plates on the tricons, refer to TM 55-8145-200-13&P.

2-15. OPERATING AUXILIARY EQUIPMENT.**WARNING**

Engine driven water pumps must not be operated in enclosed areas unless exhaust discharge is properly vented to the outside. Be alert at all times during operation for odors and symptoms of carbon monoxide exposure.

- a. 600 Gpm Pumps. Instructions for operating the 600 gpm pumps are contained in the applicable TM.
- b. 125 Gpm Pumps. Instructions for operating the 125 gpm pumps are contained in the applicable TM.

2-15. OPERATING AUXILIARY EQUIPMENT- cont.

- c. 20K Collapsible Fabric Tanks Instructions for operating the 20,000 gallon collapsible fabric tanks are contained in the applicable TM.

WARNING

Chemicals used for operating the hypochlorination unit can kill you. The chemicals alone or in mixture can be dangerous. Always wear protective apron, goggles and gloves, and make sure area is well ventilated.

- d. Hypochlorination Unit Instructions for operating the hypochlorination units are contained in the applicable TM.
- e. Tricon Instructions for operating the tricons are contained in TM 55-8145-200-13&P.

2-16. PREPARATION FOR MOVEMENT.**NOTE**

The TWDS disassembly sequence may be modified to meet your mission requirements.

- a. Disassemble Distribution Points Refer to figure 2-31.

WARNINGS

- To prevent injury to personnel, all water pumps must be shutdown and water pressure relieved from system before disconnecting couplings.
- To prevent contamination of water system components, keep dirt mud, sand, and debris from entering open components during disassembly. Make sure protective caps and plugs are installed as components are removed.

NOTES

- Refer to para 2-1 id to disconnect quick disconnect couplings.
- Disassembly of one distribution point is shown, the other is similar.
 - (1) Disconnect elbow valve (24) from 2 Inch x 20 feet discharge hose (23).
 - (2) Disconnect 2 inch x 20 feet discharge hose (23) from Y-fitting (20).
 - (3) Disconnect elbow valve (22) from 2 inch x 20 feet discharge hose (21).
 - (4) Disconnect 2 inch x 20 feet discharge hose (21) from Y-fitting (20).
 - (5) Disconnect Y-fitting (20) from 2 inch x 20 feet discharge hose (19).
 - (6) Disconnect 2 inch x 20 feet discharge hose (19) from 2 inch gate valve assembly (18).
 - (7) Disconnect 2 inch gate valve assembly (18) from Y-fitting (10).

2-16. PREPARATION FOR MOVEMENT-cont.

- (8) Disconnect 1 1/2 inch distribution nozzle (17) from 2 inch x 20 feet discharge hose (16) Figure 2-31 Distribution Point Disassembly.

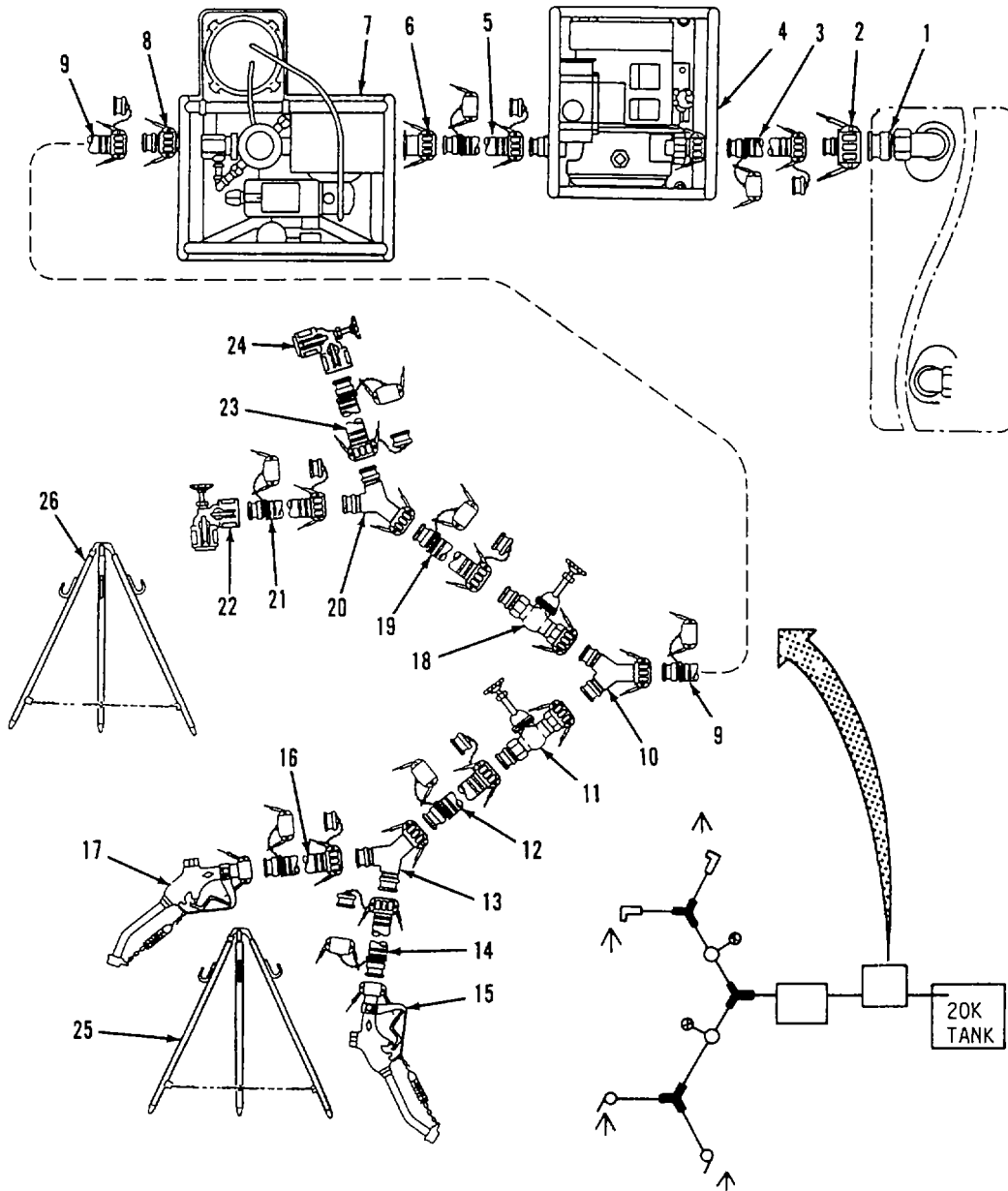

Figure 2-31. Distribution Point assembly.

2-16. PREPARATION FOR MOVEMENT-cont.

- (9) Disconnect 2 inch x 20 feet discharge hose (16) from Y-fitting (13).
- (10) Disconnect 1 1/2 inch distribution nozzle (15) from 2 inch x 20 feet discharge hose (14).
- (11) Disconnect 2 inch x 20 feet discharge hose (14) from Y-fitting (13).
- (12) Disconnect Y-fitting (13) from 2 inch x 20 feet discharge hose (12).
- (13) Disconnect 2 inch x 20 feet discharge hose (12) from 2 inch gate valve assembly (11).
- (14) Disconnect 2 inch gate valve assembly (11) from Y-fitting (10).
- (15) Disconnect Y-fitting (10) from 2 inch x 20 feet discharge hose (9).
- (16) Disconnect 2 inch x 20 feet discharge hose (9) from adapter (8), if installed. If adapter is not installed, disconnect hose from outlet port of hypochlorination unit (7).
- (17) Disconnect end of 2 inch x 10 feet discharge hose (5) from adapter (6), if installed. If adapter is not installed, disconnect hose from inlet port of hypochlorination unit (7).
- (18) If installed, disconnect 2 inch female x 1 1/2 inch male adapter (6) from inlet port of hypochlorination unit (7). Disconnect 1 1/2 inch female x 2 inch male adapter (8) from outlet port of hypochlorination unit (7).
- (19) Remove hypochlorination unit (7) from distribution point. Prepare hypochlorination unit for movement (refer to the applicable TM).
- (20) Disconnect 2 inch x 10 feet discharge hose (5) from discharge (outlet) port on 125 gpm pump (4).
- (21) Disconnect 2 inch x 10 feet suction hose (3) from suction (inlet) port on 125 gpm pump (4).
- (22) Remove 125 gpm pump (4) from distribution point. Prepare 125 gpm pump (4) for movement (refer to the applicable TM).
- (23) Disconnect 2 inch x 10 feet suction hose (3) from 4 inch female x 2 inch male adapter (2).
- (24) Disconnect 4 inch female x 2 inch male adapter (2) from male discharge elbow (1) on 20K collapsible fabric tank.
- (25) Fold nozzle stand assemblies (25 and 26).
- (26) Drain and allow components to dry.
- (27) Install caps and plugs on component couplings (para 2-11d).
- (28) Roll all hoses and secure with tape.

2-16. PREPARATION FOR MOVEMENT-cont.

- b Disassemble Storage Assembly Refer to figure 2-31.

NOTES

- Disassembly of one storage assembly is shown, the other is similar.
 - Refer to para 2-11d to disconnect quick disconnect couplings.
- (1) Disconnect 4-inch x 10 feet suction hose (13) from female elbow (14) (inlet) on 20K collapsible tank (15).
 - (2) Disconnect four 4-inch x 10 feet suction hoses (10, 11, 12 and 13) from 4-inch gate valve (8).
 - (3) Disconnect water meter (9) from 4-inch gate valve (8).
 - (4) Disconnect 4-inch gate valve (8) from adapter (7).

NOTE

Refer to para 2-11e to remove coupling clamps.

- (5) Remove coupling clamp (6) and disconnect adapter (7) from reducer tee (1).
- (6) Remove coupling clamp (4) and disconnect 6-inch x 500 feet discharge hose (5) from reducer tee (1).
- (7) Remove coupling clamp (2) and disconnect reducer tee (1) from 6-inch x 500 feet discharge hose (3).
- (8) Drain and prepare 20K collapsible tank (15) for movement. Refer to the applicable TM.

2-16. PREPARATION FOR MOVEMENT- cont.

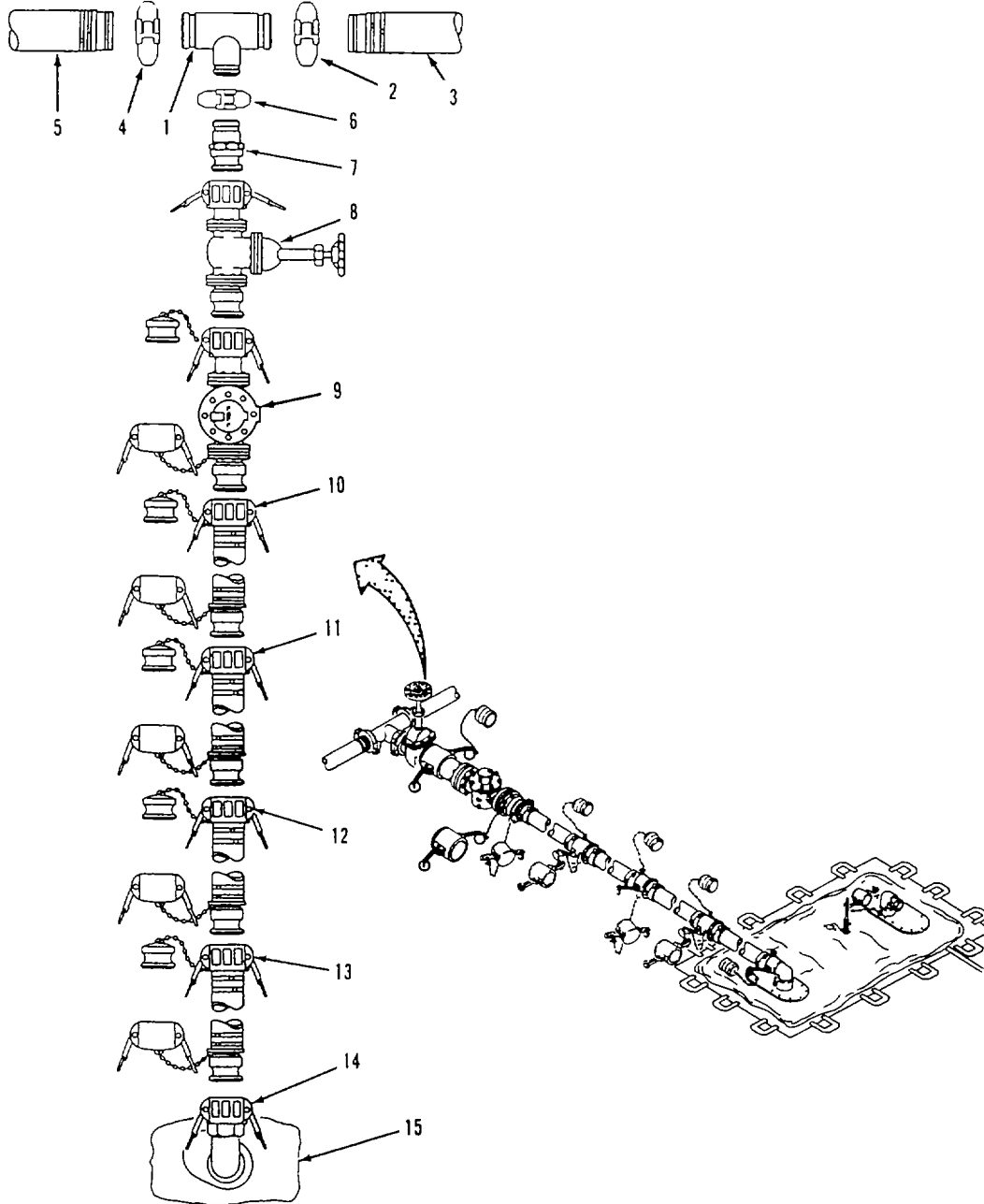

Figure 2-31. Storage Assembly Disassembly.

2-16. REPARATION FOR MOVEMENT-cont.

- c. Remove Roadway Crossing Guards. Refer to figure 2-32.

CAUTION

Use care when removing dirt from top of road crossing guards to prevent damage to hose.

NOTE

Removal of one roadway crossing guard is shown Removal of remaining guards is similar.

- (1) Remove dirt from top of road crossing guards (4).
- (2) If planks (3) have been installed, remove nails from crossing guards (4).
- (3) Remove crossing guards (4) from trench (1).
- (4) Lift hose (2) from trench (1).
- (5) Clean roadway crossing guards (4) and transport to packing area.

2-16. PREPARATION FOR MOVEMENT-cont.

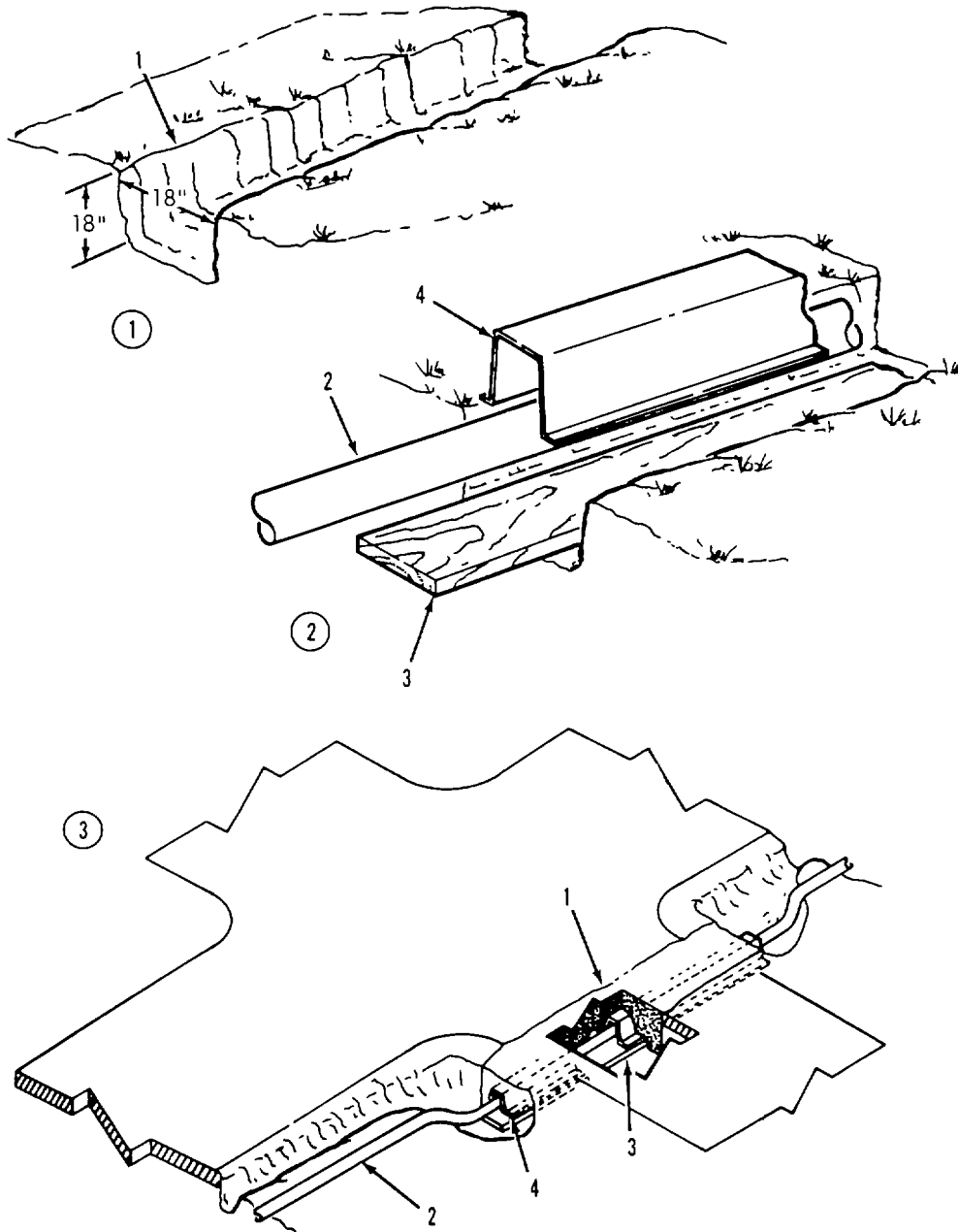

Figure 2-32. Roadway Crossing Guard Removal.

2-16. PREPARATION FOR MOVEMENT-cont.d. Disassemble Hose Suspension Kits.

NOTE

Disassembly of one hose suspension kit is shown. Disassembly of remaining kits is similar.

Lowering Hoseline Refer to figure 2-33.

- (1) Disconnect suspended hose (2) from upline and downline hose segments by removing coupling clamps (para 2-1 le). Allow suspended hose to drain.
- (2) Remove three clamps (7) securing shackles (4) to end of wire rope (3). Repeat for other end of suspended hose (2).
- (3) Pull suspended hose (2) along wire rope (3) to upline tripod (9) until shackle (4) contacts tackle block (8).
- (4) While supporting saddle (5) and hose (2), remove bolt (6) from shackle (4).
- (5) Lower hose (2) and remove saddle (5) from hose.
- (6) Remove shackle (4) from wire rope (3).
- (7) Repeat steps (3) through (6) until suspended hose is pulled from wire rope (3) and all saddles (5) are removed.
- (8) Untie manila rope (1) from leading end of hose (2).

2-16. PREPARATION FOR MOVEMENT-cont.

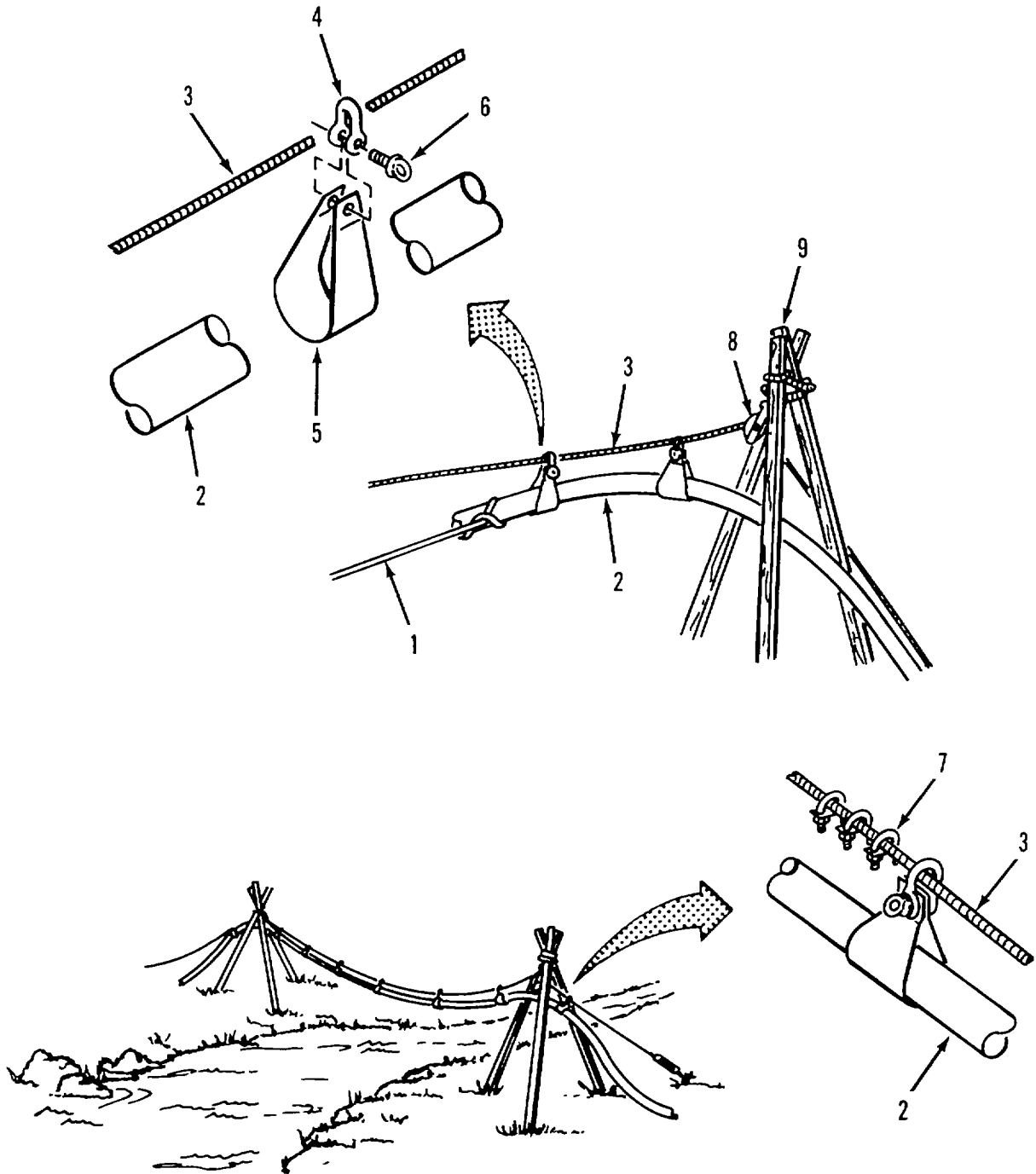

Figure 2-33. Lowering Hoseline.

2-16. PREPARATION FOR MOVEMENT-cont.

Disassemble Wire Rope and Turnbuckles Refer to figure 2-34.

- (9) Loosen turnbuckles (9) at both ends of wire rope (7).
- (10) Disconnect wire rope (7) from turnbuckles (9).
- (10) Disconnect turnbuckles (9) from stakes (10).
- (11) If wire rope (7) can be reused, remove loop from both ends of rope as follows.
 - (a) Remove two nuts (4), clamp (5) and U-bolt (6) from wire rope (7).
 - (b) Remove two nuts (1), clamp (2), U-bolt (3) and thimble (8) from wire rope (7).
- (12) Pull wire rope (7) across obstruction. Coil wire rope for storage.
- (13) Remove tackle block (8, figure 2-30) from each tripod (9).

2-16. PREPARATION FOR MOVEMENT - cont.

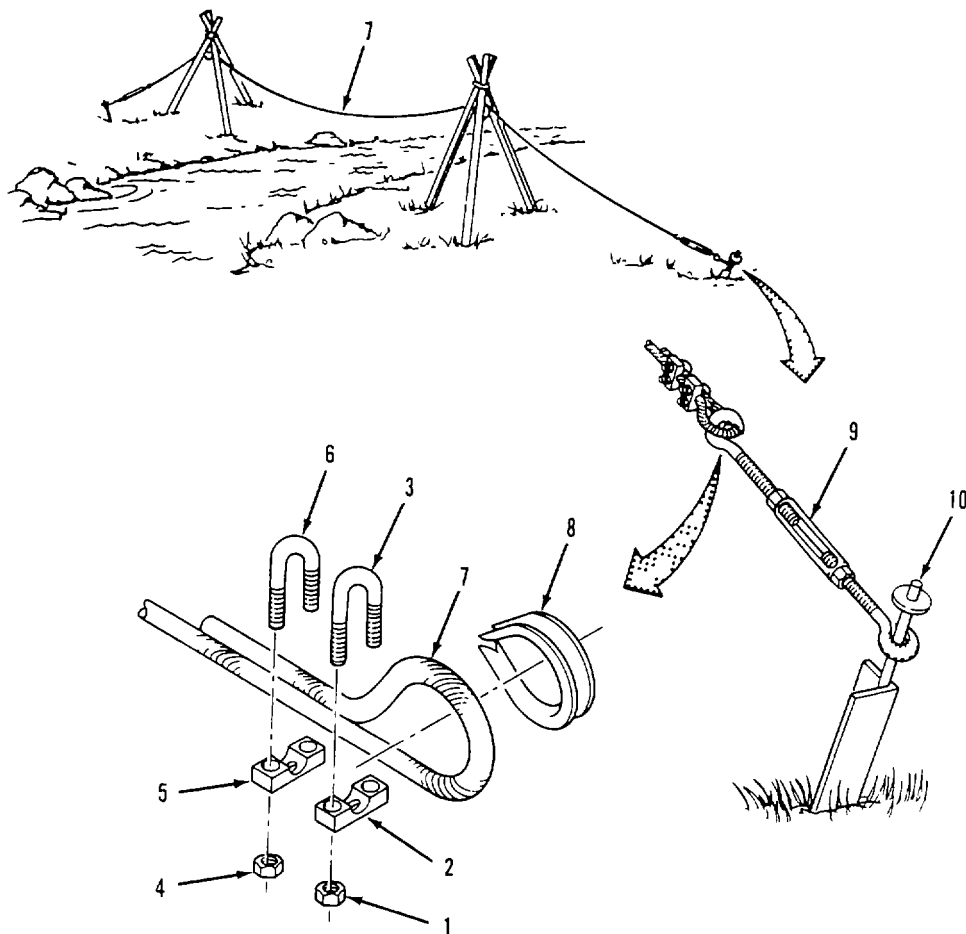

Figure 2-34. Wire Rope and Turnbuckle Disassembly

2-16. PREPARATION FOR MOVEMENT - cont.e. Hoseline Disassembly and Packing Requirements

(1) Disassembly of the 10-mile hoseline segment requires sufficient tools, equipment and personnel to perform the tasks outlined in the following paragraphs. The displacement and evacuation kit, and the packing kit will be required to pack hoseline segments in the flaking boxes. If a forklift is not available, the lifting sling will be required to load, unload, and stack flaking boxes onto the cargo truck.

(2) When flaking boxes are returned to packing site, stack flaking boxes four high.

f. Purge and Evacuate Hoseline. Components required to perform this procedure are located in the displacement and evacuation kit.**NOTES**

- Begin disconnecting and evacuating hoseline at lead pumping station and proceed downline.
- Disconnection and evacuation of one hose segment is shown.
- Disconnection and evacuation of remaining hose segments is the same.
- Refer to para 2-11e to remove and install coupling clamps.

Purging. Refer to figure 2-35.

- (1) Open all butterfly valves at each pumping station.
- (2) Position air compressor between hoses (2 and 5).
- (3) Remove coupling clamp (1) and disconnect hose (2) from butterfly valve (3) at lead pumping station.
- (4) Remove coupling clamp (4) and disconnect hose (2) from hose (5).
- (5) Remove coupling clamp (6) and disconnect hose (5) from swivel (8).
- (6) Connect nipple (10) to downline end of hose (2) with coupling clamp (4).
- (7) Insert displacement ball (11) into nipple (10).
- (8) Connect ball inlet assembly (12) to nipple (10) with quick disconnect coupling clamp (13).
- (9) Connect air supply hose (14) to air coupling (15) on ball inlet assembly (12).
- (10) At upline end of hose (2), connect 6 inch x 8 inch reducer (16) to hose (2) with coupling clamp (18).

2-16. PREPARATION FOR MOVEMENT - cont.

NOTE

The caged reducer is identified by a metal bar welded inside the reducer body.

- (11) Connect 6 inch x 8 inch caged reducer (17) to 6 inch x 8 inch reducer (16) with quick disconnect coupling clamp (18).

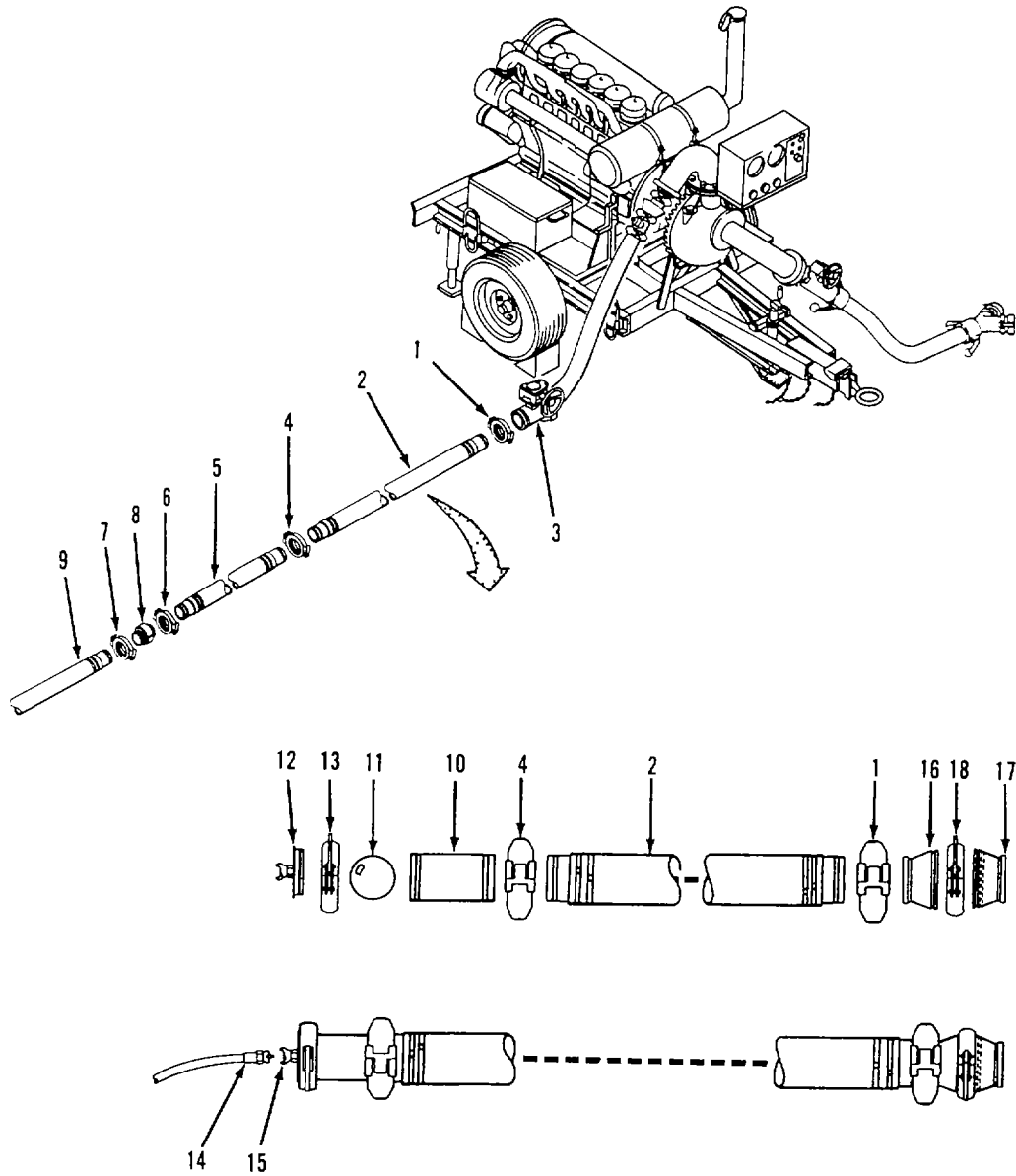

Figure 2-35. Hoseline Purging.

2-16. PREPARATION FOR MOVEMENT - cont.**WARNING**

To prevent injury to personnel, stand clear of ball receiver when applying air pressure. Hose may jump when ball arrives at ball receiver.

NOTE

If displacement ball gets stuck in hose, straighten kinks in hose. It may be necessary to increase air pressure. Do not exceed 150 psi.

- (12) Pressurize air supply hose (14) to 80 to 90 psi. Displacement ball (11) will be forced through hose (2), displacing any residual water. A sound will be heard when displacement ball reaches ball receiver.
- (13) Shut off air supply when displacement ball (11) enters caged reducer (17).
- (14) Remove quick disconnect coupling clamp (18) and separate caged reducer (17) from reducer (16). Remove displacement ball (11) from caged reducer.
- (15) Remove coupling clamp (1) and separate reducer (16) from end of hose (2).

Evacuation. Refer to figure 2-36.

- (16) Connect cap (2) to hose (3) with coupling clamp (1).
- (17) Connect ejector (5) to ball inlet (6).
- (18) Connect air supply hose (4) to ejector (5).
- (19) Pressurize air supply hose (4) to ejector (5).
- (20) Shut off air supply to ejector (5) when hose (3) has collapsed.
- (21) Disconnect air supply hose (4) from ejector (5).
- (22) Disconnect ejector (5) from ball inlet (6).
- (23) Remove coupling clamp (1) and disconnect cap (2) from hose (3).
- (24) Remove coupling clamp (4, figure 2-35) and separate nipple (10) and attached parts from hose (2).
- (25) Repeat steps (3) through (23) for hose (5), except work from upline end of hose to downline end to prevent having to move air compressor.
- (26) Repeat steps (3) through (24) for all remaining downline hoses while removing coupling clamps (7) and swivels (8) from hoses (9) where required.
- (27) Pack evacuation kit components in storage chest.

2-16. PREPARATION FOR MOVEMENT - cont.

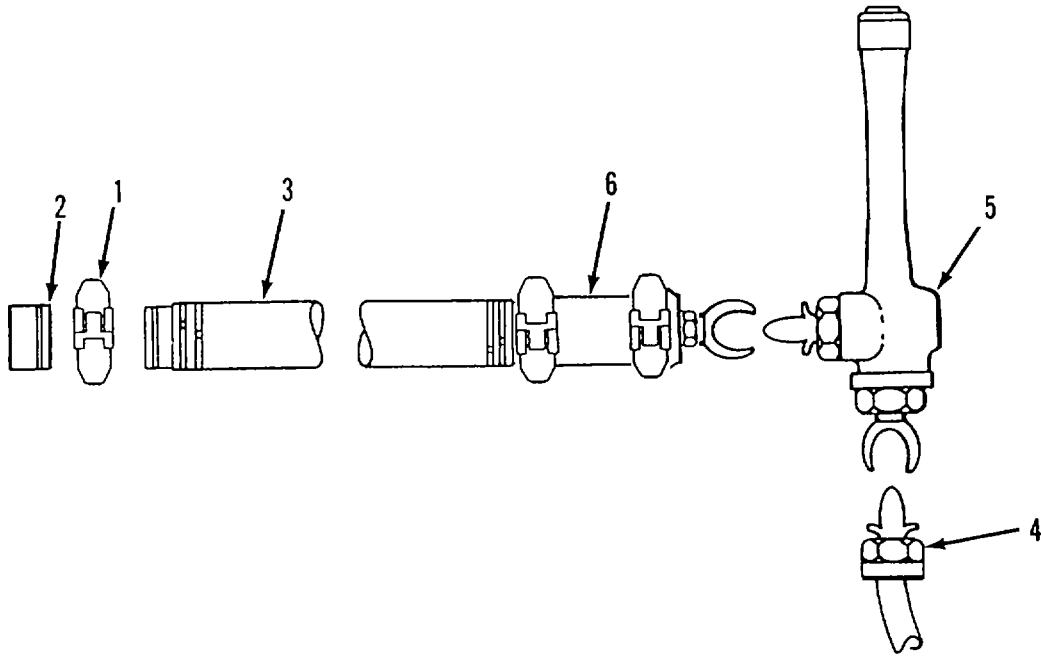

Figure 2-36. Hoseline Evacuation.

2-16. PREPARATION FOR MOVEMENT- cont.g. Pack Flaking Box Assemblies.**NOTE**

Prepare hose segments for flaking operations by connecting all hoses into 1,000 ft hose lengths.

Fold Hose. Refer to figure 2-37.

CAUTION

To prevent damage to hoses, remove sharp objects from empty flaking boxes. Rocks and sharp objects pressed against hose during packing may puncture hose.

- (1) Remove rocks, dirt and debris from empty flaking boxes. Check flaking box for missing thumbscrews, cracked or damaged frame and corrosion.
- (2) Load empty flaking box onto cargo truck (refer to para 2-11h).
- (3) Transport empty flaking box and hoseline packing kit to leading end of first hose segments to be packed.

NOTE

Components required to pack the flaking box are located in the hoseline packing kit.

- (4) Screw nut (3) all the way onto eyebolt (2).
- (5) Insert eyebolt (2) and attached nut (3) into hole in front wall (4) of flaking box (5).
- (6) Secure eyebolt (2) to front wall with nut (1).
- (7) Place leading end of hose (6) at left rear corner of flaking box (5) Leave about 3 feet of hose hanging from rear of flaking box.
- (8) Press hose (6) against left wall (7), then along front wall (4) of flaking box (5) as shown.
- (9) When hose (6) reaches right wall (8), fold hose back across front wall (4) to left wall (7).

NOTE

Folds in hose should be 1/2 inch shorter than width of flaking box interior. If hose is tight against sides of flaking box, compressing hose with pullboard will be difficult.

- (10) Continue to fold hose (6) in a right-to-left/left-to-right pattern until about 150 feet of hose has been flaked.

2-16. PREPARATION FOR MOVEMENT - cont.

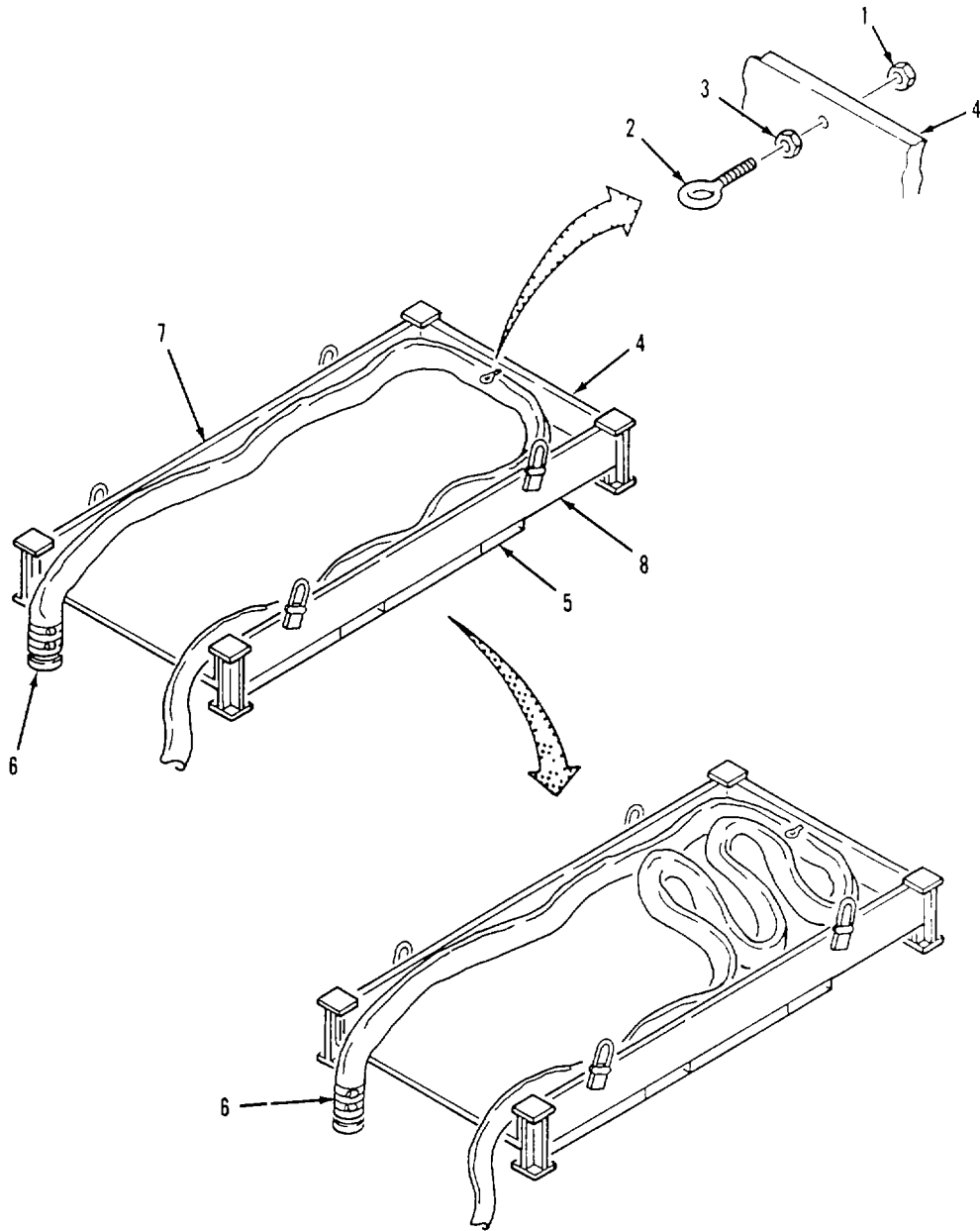

Figure 2-37. Folding Hose.

2-16. PREPARATION FOR MOVEMENT- cont.

Assemble Pullboard. Refer to figure 2-38.

- (11) Aline pullboard halves (1) as shown.
- (12) Slide coupling sleeve (2) over the top of pullboard halves (1) and aline mounting holes.
- (13) Install two screws (5), flat washers (4) and self locking nuts (3) through coupling sleeve (2).
- (14) Install nut (9) and flat washer (8) on eyebolt (10). Screw nut all the way onto eyebolt.
- (15) Install eyebolt (10) and attached parts into coupling sleeve (2). Make sure eyebolt is on opposite side of flanges (13).
- (16) Install flat washer (7) and nut (6) on eyebolt (10).

Compressing Hose. Refer to figure 2-38.

- (17) Place assembled pullboard (11) in flaking box (14) with flanges (13) pointing to rear of box and eyebolt (10) pointing to front of box. Flanges (13) must fit under metal rim (15) on left and right sides of box.
- (18) Connect hoist (12) to eyebolt (16) on front wall of flaking box (14) and eyebolt (10) on pullboard (11).
- (19) Operate handle on hoist (12). As pullboard (11) is drawn to front of flaking box (14), hose (17) will begin to compress.
- (20) When hose (17) is tightly compressed, press retaining brackets (18) between folds in hose, about two folds in front of pullboard (11). Brackets must be positioned under metal rims (15) on left and right sides of flaking box (14).
- (21) Push up on toggle levers (19) and lock brackets (18) against metal rims (15).
- (22) Release tension on hoist (12) and remove pullboard (11) from flaking box (14).
- (23) Continue to fold hose (17) in a right-to-left/left-to-right pattern until about 150 feet of hose has been folded.
- (24) Repeat steps (17), (18) and (19) to compress hose (17).
- (25) Push down on toggle levers (19) and remove two retaining brackets (18).
- (26) Slide retaining brackets (18) down between folds in hose (17). Brackets should be positioned about two folds in front of pullboard (11), and under metal rims (15) on left and right sides of flaking box (14).

2-16. PREPARATION FOR MOVEMENT - cont.

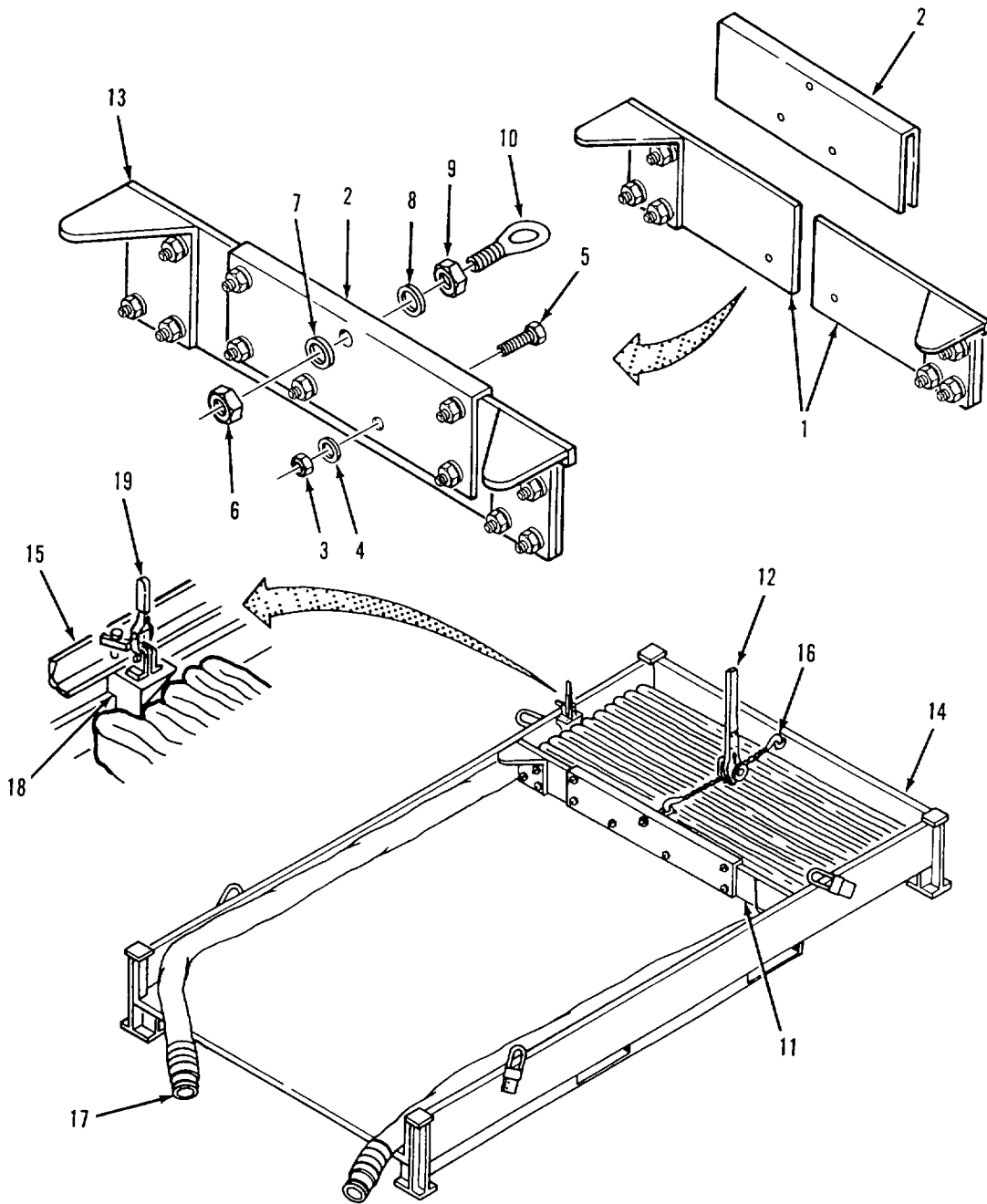

Figure 2-38. Assemble Pullboard and Compress Hose.

2-16. PREPARATION FOR MOVEMENT - cont.

- (27) Push up on toggle levers (19) and lock retaining brackets (18) against metal rims (15).
- (28) Repeat steps (17) through (28) until entire hose length(1000 feet) has been packed in flaking box.
- (29) Remove pullboard (11), hoist (12) and retaining brackets (18) from flaking box (14).
- (30) Remove nut (1, figure 2-34) and eyebolt (2) from front wall of flaking box (4).

Install Tailgate. Refer to figure 2-39.

- (31) Slide tail gate (1) down into flaking box (2). Make sure notches (3) at bottom of tail gate align with studs (4) in flaking box.
- (32) Install two thumbscrews (5) through flaking box (2) and into tailgate (1). Make sure thumbscrews are tight.

WARNING

To prevent injury to personnel and damage to the equipment, do not stack flaking boxes more than four high.

- (33) Repeat steps (1) through (32) until all hoses have been packed.

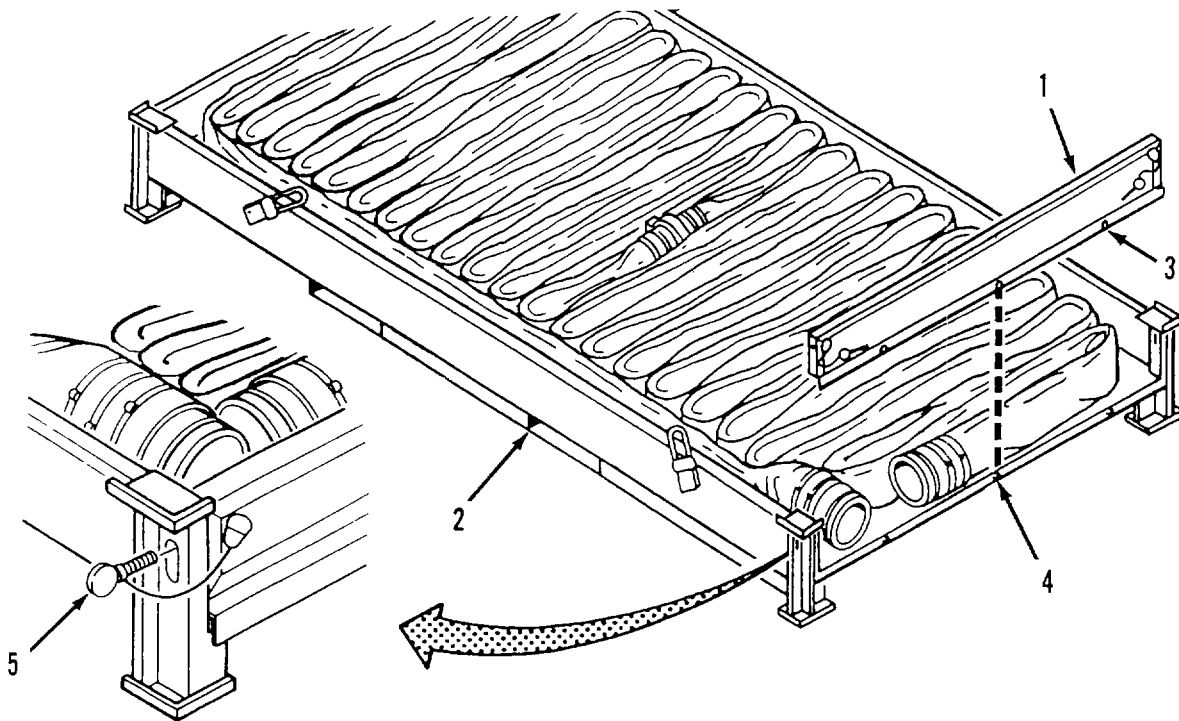

Figure 2-39. Tailgate Installation.

2-16. PREPARATION FOR MOVEMENT - cont.

- h. Disassemble Boost Pumping Stations Refer to figure 2-40.

WARNING

To prevent contamination of water system and damage to components, keep rocks, dirt, mud, sand and debris from entering open couplings and hoses during disassembly.

NOTE

- Disassembly of one boost pumping station is shown. Disassembly of three remaining boost pumping stations is similar.
- Refer to para 2-11e to remove coupling clamps.

Bypass Line.

- (1) Remove coupling clamp (21) and disconnect end of 6-inch x 50-foot discharge hose (20) from lateral pipe fitting (wye) (10).
- (2) Remove coupling clamp (19) and disconnect 6-inch x 50-foot discharge hose (20) from butterfly valve (18).
- (3) Remove coupling clamp (17) and disconnect butterfly valve (18) from lateral pipe fitting (wye) (16).

Suction Line.

- (4) Remove coupling clamp (15) and disconnect lateral pipe fitting (wye) (16) from butterfly valve (14).
- (5) Remove coupling clamp (13) and disconnect butterfly valve (14) from 6-inch x 10-foot discharge hose (12).
- (6) Remove coupling clamp (11) and disconnect 6-inch x 10-foot discharge hose (12) from suction port on 600 8pm pump.

Discharge Line.

- (7) Remove coupling clamp (9) and disconnect lateral pipe fitting (wye) (10) from butterfly valve (8).
- (8) Remove coupling clamp (7) and disconnect butterfly valve (8) from 6-inch x 20-foot discharge hose (6).
- (9) Remove coupling clamp (5) and disconnect 6-inch x 20-foot discharge hose (6) from pressure relief valve (4).
- (10) Remove coupling clamp (3) and disconnect pressure relief valve (4) from check valve (2).

2-16. PREPARATION FOR MOVEMENT - cont.

- (11) Remove coupling clamp (1) and disconnect check valve (2) from discharge port on 600 gpm pump.
- (12) Prepare 600 gpm pump for movement Refer to the applicable TM.
- (13) Repeat steps (1) through (12) for remaining boost pumping stations.

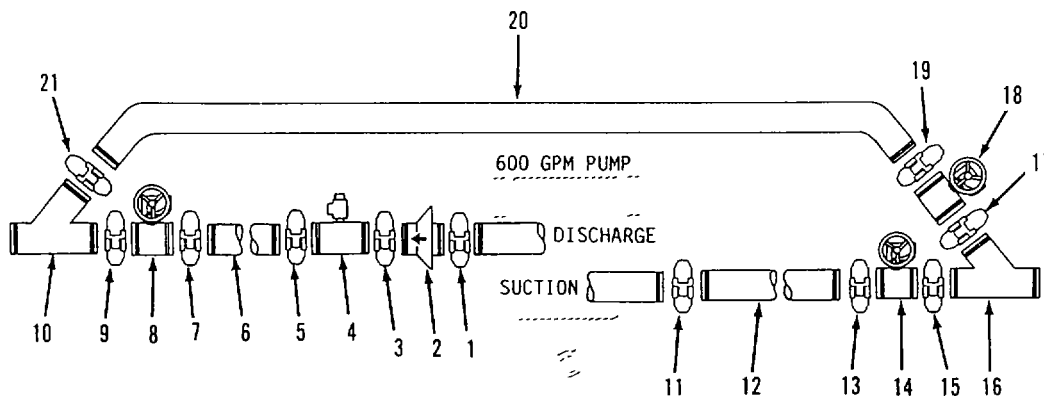
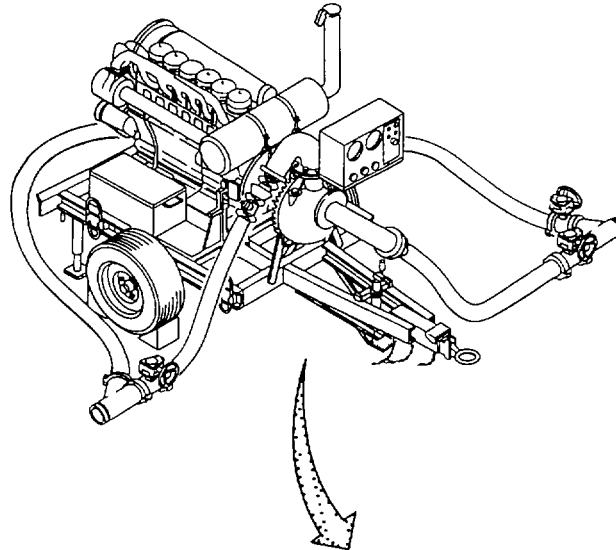

Figure 2-40. Boost Pumping Station Disassembly.

2-16. PREPARATION FOR MOVEMENT - cont.

- i. Disassemble Lead Pumping Station Refer to figure 2-41.

WARNING

To prevent contamination of water system and damage to components, keep rocks, dirt, mud, sand and debris from entering open couplings and hoses during disassembly.

NOTE

Refer to para 2-11d to disconnect quick disconnect coupling. Refer to para 2-11e to remove coupling clamps.

Suction Line.

- (1) Disconnect reducing wye (15) from water source.
- (2) Disconnect reducing wye (15) from 6-inch x 10 foot suction hose (14).
- (3) Disconnect 6-inch x 10-foot suction hose (14) from coupling half(13).

NOTE

Suction hose, coupling pipe fitting, coupling half and reducer wye are separately packaged.

- (4) Remove coupling clamp (11) and disconnect assembled fitting (12) and coupling half(13) from butterfly valve (10). If required, unscrew fitting (12) from coupling half(13).
- (5) Remove coupling clamp (9) and disconnect butterfly valve (10) from suction port on 600 gpm pump.

Discharge Line.

- (6) Remove coupling lamp (7) and disconnect butterfly valve (8) from 6-inch x 20 foot discharge hose (6).
- (7) Remove coupling clamp (5) and disconnect 6-inch x 20-foot discharge hose (6) from pressure relief valve (4).
- (8) Remove coupling clamp (3) and disconnect pressure relief valve (4) from check valve (2).
- (9) Remove coupling clamp (1) and disconnect check valve (2) from discharge port on 600 gpm pump.
- (10) Prepare 600 gpm pump for movement. Refer to the applicable TM.

2-16. PREPARATION FOR MOVEMENT - cont.

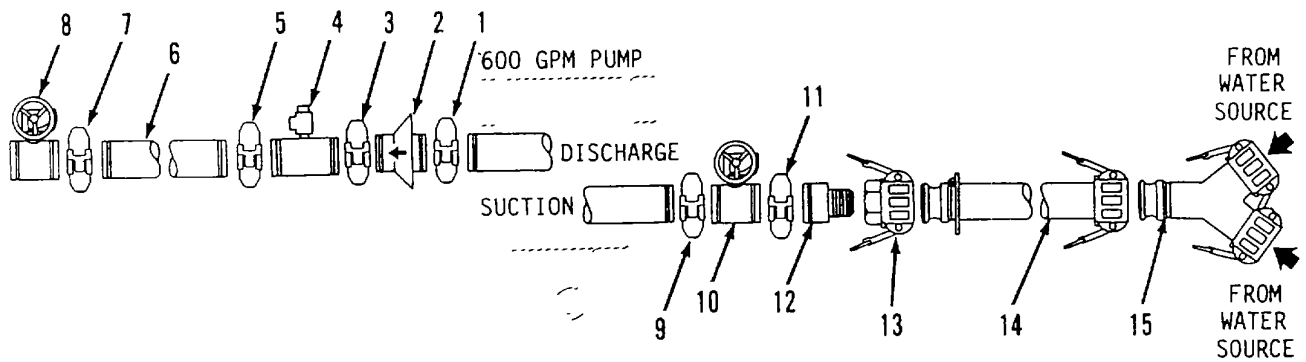
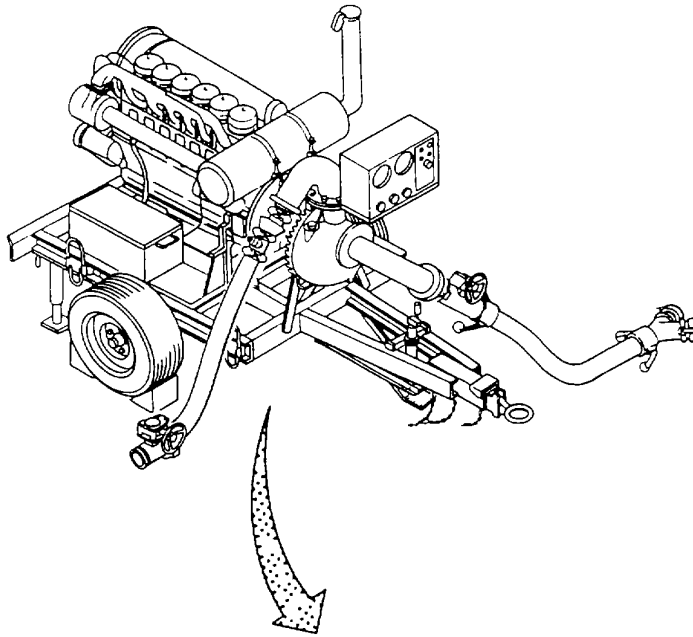

Figure 2-41. Lead Pumping Station Disassembly.

2-16. PREPARATION FOR MOVEMENT - cont.j. Packing.

- (1) Open TRICONS. Refer to the applicable TM.

WARNING

To prevent build up of explosive fuel vapors and toxic chemical vapors, do not pack 125 gpm pumps, hypochlorination units or 600 gpm pumps in TRICONS.

- (2) Pack water system components into tricons. If possible, keep similar components stowed together. For example, pack all 6-inch discharge hoses together, then all the 4-inch gate valves, 2-inch discharge hoses and so on until all components are stowed.
- (3) Close tricon containers Refer to TM55-8145-200-13&P.
- (4) Prepare hypochlorination units for movement.
- (5) Prepare 125 gpm pumps for movement.
- (6) Prepare 600 gpm pumps for movement.
- (7) Stack flaking boxes. Do not exceed four boxes per stack.

Section IV. OPERATION UNDER UNUSUAL CONDITIONS**2-17. OPERATION IS EXTREME COLD (BELOW 32°F (0°C)).**

- a. When the air temperature is expected to be 32°F (0°C) or below, set up the water system using the minimum number of components required to accomplish your mission.
- b. Observe the following precautions when operating the water system in extreme cold.
 - (1) Wear arctic mittens and rubber gloves when handling hardware. Bare hands can freeze to metal components. Change mittens if they get wet.
 - (2) Take advantage of existing shelter and windbreaks during system installation.
 - (3) Erect tents or shelters for protection. The collapsible tanks must be installed inside a tent or other shelter when temperature falls below freezing. Fuel, coal or wood burning heaters or other heating devices may be installed inside the erected tents to protect the equipment and prevent freezing of water.
 - (4) Do not operate heater in fuel vapor areas or areas lacking adequate ventilation. Inhalation of fumes will result in serious illness or death.
 - (5) Avoid unnecessary folding, unfolding or rolling of hoses and water tanks in freezing temperatures. Cracks can develop in hose and tank fabric.
 - (6) Remove snow, sleet or ice from water tanks and water pumps. Be careful to prevent cracking of tank fabric.
 - (7) Turn valve control handwheels slowly during cold weather. Internal seals may have become stiff and brittle.
 - (8) Remove snow, sleet or ice from hose couplings before making connections.
 - (9) When not in use, store water hoses and tanks in a heated area to avoid freezing. If frozen, disconnect hoses and move them to a heated area until they thaw.
 - (10) Refer to the applicable TM for operating the 600 gpm pump in extreme cold.
 - (11) Refer to the applicable TM for operating the 125 GPM pump in extreme cold.
 - (12) Refer to the applicable TM for operating the hypochlorination in extreme cold.
 - (13) Refer to the applicable TM for operating the 20K collapsible fabric tanks in extreme cold.
 - (14) Monitor water system during operation for split, clogged or frozen hoses.

2-17. OPERATION IN EXTREME COLD (BELOW 32°F (0°C)) - cont.**CAUTION**

To prevent damage to the equipment, all hoses must be disconnected from the water pumps, hypochlorination units and collapsible tanks. Pumps, tanks, and hoses must be drained quickly. All control valves must be opened and all equipment inspected to assure complete drainage.

- c. If equipment is shut down during cold weather (temperature falls below 32°F (0°C)), perform the following steps to ensure water is drained from collapsible tanks, hoses, valves, pumps and connections.

Lead and Boost Pumping Stations.

- (1) Open all butterfly valves.
- (2) Disconnect hoses from lead and boost pumping stations. Allow water to drain from pumps, hoses and couplings.
- (3) Drain water from 600 gpm water pumps. Refer to the applicable TM for operating the 600 gpm pumps in extreme cold.

Storage Assemblies.

- (4) Open water inlet gate valve.
- (5) Drain 20K collapsible fabric tanks. Refer to applicable TM for operating the fabric tanks in extreme cold.
- (6) Allow water to drain from hoses and couplings.

Distribution Points.

- (7) Open all dispensing nozzles, elbow valves and gate valves. Allow water to drain from pumps, hoses, couplings and hypochlorination unit.
- (8) Disconnect and drain 125 gpm water pumps. Refer to the applicable TM for operating the 125 gpm pump in extreme cold.
- (9) Disconnect and drain hypochlorination units. Refer to the applicable TM for operating the hypochlorination units in extreme cold.

*Hoseline.***CAUTION**

All low spots along hoseline route must be opened to allow water to drain from hose. Ice in hoseline will damage hose and pumping equipment.

- (10) Remove couplings from hoseline and allow water to drain.

2-18. OPERATION IN EXTREME HEAT.

Observe the following precautions when operating the water system in extreme heat.

Lead and Boost Pumping Stations.

- (1) Protect pumping stations from direct sunlight. If shade is not available, construct sun blocks or erect portable shelters. Monitor 600 gpm pumps for overheating.
- (2) Refer to the applicable TM for operating the 600 gpm pumps in extreme heat.

Storage Assemblies and Distribution Points.

- (3) Protect storage and distribution points from direct sunlight. Set up collapsible tanks, water pumps and hypochlorination unit, in shaded area. If shade is not available, protect water tanks from direct sunlight by constructing sun blocks or erecting portable shelters.
- (4) Make sure air flow can circulate freely around collapsible tanks. Avoid unnecessary folding, unfolding or rolling of empty water tanks and hoses. Do not store unused tank in direct sunlight.
- (5) Refer to the applicable TM for operating the 125 GPM pump in extreme heat.
- (6) Refer to the applicable TM for operating the hypochlorination unit in extreme heat.
- (7) Refer to the applicable TM for operating the 20K water tanks in extreme heat.
- (8) Monitor water supply for excessive bacterial and algae growth. Adjust output of hypochlorination units as directed by medical personnel. Refer to the applicable TM.

2-19. OPERATIONS IN DUSTY OR SANDY AREAS.

Observe the following precautions when operating the water system in dusty or sandy areas.

- (1) Keep dust caps in place on fittings and couplings until ready for use. Cover all open hose ends with plastic bags or other suitable material until ready for use.
- (2) Carefully inspect coupling gaskets before connecting fittings. Remove all dirt, sand and debris before making connections.
- (3) Refer to the applicable TM for operating the 600 GPM pump in dusty or sandy areas.
- (4) Refer to the applicable TM for operating the 125 GPM pump in dusty or sandy areas.
- (5) Refer to the applicable for operating the hypochlorination unit in dusty or sandy areas.
- (6) Refer to the applicable TM for operating the water tanks under in dusty or sandy areas.

2-19. OPERATIONS IN DUSTY OR SANDY AREAS - cont.

- (7) Following operation in dusty or sandy areas, rinse all components with clean, fresh water to remove sand, dust and grit. Direct special attention to quick disconnect coupling gaskets and locking arms.

2-20. OPERATION IN SALT WATER AREAS.

Operation in salt water areas accelerates corrosion on bare metal surfaces. Observe the following precautions when operating the water system in this environment.

- (1) Carefully inspect water system components during installation. If bare metal is found, notify unit maintenance to preserve or paint the metal as required.
- (2) Refer to the applicable TM for operation of the 600 gpm pump in salt water areas.
- (3) Refer to the applicable TM for operation of the 125 gpm pump in salt water areas.
- (4) Refer to the applicable TM for operation of the hypochlorinator unit in salt water areas.
- (5) Refer to the applicable TM for operation of the 20K collapsible fabric tanks in salt water areas.
- (6) Following operation in salt water areas, rinse components with clean fresh water, to remove salt spray and/or deposits.

2-21. EMERGENCY PROCEDURES.

The TWDS provides sufficient water storage and pumping capacity to allow isolation and redirection of water flow around failed pumping components without a severe drop in operational capacity. Failure of the lead pumping station 600 gpm pump will require replacement of the pump for continued system operation.

- a. Lead Pumping Station Failure Refer to figure 2-30.

CAUTION

To prevent damage to the equipment, downline boost pumping stations must be shutdown if lead pumping station is inoperable.

- (1) Shutdown boost pumping stations (para 2-13d).
- (2) Shutdown 600 gpm pump at lead pumping station (para 2-13d).
- (3) Close valves L1 and L2.
- (5) Remove lead pumping station components from 600 gpm pump (para 2-16i).
- (6) Remove defective 600 gpm pump from water system.
- (7) Position spare 600 gpm pump in lead pumping station.

2-21. EMERGENCY PROCEDURES-cont.

- (8) Connect lead pumping station components to 600 gpm pump (para 2-11f).
 - (9) Open valves L1 and L2.
 - (10) Fill hoseline (para 2-13b).
 - (11) Startup water system (para 2-13c).
- b. Boost Pumping Station Failure Refer to figure 2-30.
- (1) Shutdown defective 600 gpm pump. Refer to the applicable TM.
 - (2) Open valve B1, and close valves 1B2 and B3 to bypass defective 600 gpm pump.

NOTE

Opening valve B1 allows water to bypass the 600 gpm pump. System operation may continue while defective boost pump is being replaced.

- (3) Disconnect boost pumping station components from 600 gpm pump (para 2-16h).
 - (4) Remove defective 600 gpm pump from boost pumping station.
 - (5) Position spare 600 gpm pump in boost pumping station.
 - (6) Connect boost pumping station components to 600 gpm pump (para 2-11g).
 - (7) Connect hose to suction port on 600 gpm pump.
 - (8) Open gate valves B2 and B3, and close gate valve B1.
 - (9) Start and operate 600 gpm pump Refer to the applicable TM.
- c. Component Failure. Refer to figure 2-30 In the event of a hose, coupling, tank or valve rupture, the failed component must be isolated as soon as possible to stop the loss of water.

CAUTION

To prevent damage to the equipment, water system must be shut down if isolating the failed component(s) will block water flow to or from the 600 gpm pumps.

- (1) If failure occurs in main hoseline, shutdown lead and boost pumping stations (para 2-13d).
- (2) Close nearest upstream and downstream control valves to stop water flow through failed component.

2-21. EMERGENCY PROCEDURES - cont.

- (3) If failed component is located in one of the distribution points, shutdown the 125 gpm pump. Refer to the applicable TM.
- (4) Replace failed components (para 3-4 or 3-6).

2-22. DECONTAMINATION PROCEDURES.**NOTE**

Detailed decontamination procedures can be found in FM 3-3, FM 3-4, and FM 3-5.

- a. General. The following emergency procedures can be performed until field NBC DECON facilities are available. Assigned operators will assist the supporting NBC unit.
- b. Emergency Procedures. If NBC attack is known or suspected, mask at once and go to appropriate MOPP level as determined by level of threat.
 - (1) Stop dispensing water.
 - (2) Reduce the risk of introducing contamination into the water system by shutting down 600 gpm pumps in lead and boost pumping stations. Refer to the applicable TMs.
 - (3) Shut down hypochlorination units (refer to the applicable TM). Hypochlorite solution container is not air tight and may have been contaminated.
 - (4) Do not connect or disconnect any components from the water system. System integrity must be maintained until decontamination of equipment is complete.
 - (5) Test water for contamination using the M272 kit and provide a water sample to medical personnel before dispensing water to consumers.

CHAPTER 3

OPERATOR MAINTENANCE INSTRUCTIONS

Section I.	Lubrication Instructions.....	3-1
Section II.	Operator Troubleshooting.....	3-1
3-1.	Introduction	3-1
3-2.	Malfunction Index.....	3-2
3-3	Troubleshooting Table.....	3-2
Section III.	Operator Maintenance Procedures.....	3-26
3-4	Component Replacement (Quick Disconnect Couplings).....	3-26
3-5	Quick Disconnect Coupling Repair.....	3-28
3-6	Component Replacement (Coupling Clamps).....	3-30
3-7	Coupling Clamp Repair	3-34
3-8	Hose (6-inch) Repair.....	3-35

Section I. LUBRICATION INSTRUCTIONS

Lubrication of the Tactical Water Distribution System is limited to the 600 gpm and 125 gpm pumps. Lubricate this equipment in accordance with the applicable technical manual.

Refer to the applicable TM for lubrication requirements on the 600 gpm pumps.

Refer to the applicable TM for lubrication requirements on the 125 gpm pumps.

Section II. OPERATOR TROUBLESHOOTING

3-1. INTRODUCTION.

- a. The troubleshooting table lists the common malfunctions which you may find during operation of the water system. You should perform the tests, inspections and corrective actions in the order they appear in the table.
- b. This table cannot list all the malfunctions that may occur, all the tests or inspections needed to find the fault, or all the corrective actions needed to correct the fault. If the equipment malfunction is not listed or actions listed do not correct the fault, notify your supervisor.
- c. Refer to the applicable TM for troubleshooting malfunctions on the 600 gpm pumps.
- d. Refer to the applicable TM for troubleshooting malfunctions on the 125 gpm pumps.
- e. Refer to the applicable TM for troubleshooting malfunctions on the hypochlorination units.
- f. Refer to the applicable TM for troubleshooting malfunctions on the 20K collapsible fabric tanks.

3-2. MALFUNCTION INDEX.

Malfunction	Page
1. No Water Flow to Distribution Nozzles or Elbow Valves	3-4
2. Low Water Pressure to Distribution Nozzles or Elbow Valves.....	3-5
3. Low Water Pressure in Main Hoseline.....	3-6
4. Discharge or Suction Hose Leaks (Distribution Point).....	3-8
5. Discharge or Suction Hose Leaks (Hoseline).....	3-9
6. Gate Valve Assembly (2-Inch) (D3 or D8) Leaks.....	3-10
7. Gate Valve (2-Inch) (D3 or D8) Stuck or Jammed.....	3-11
8. Y Fitting Leaks (Distribution Point).....	3-12
9. Elbow Valve (D4 or D5) Leaks.....	3-13
10. Elbow Valve (D4 or D5) Stuck or Jammed.....	3-14
11. Distribution Nozzle (1-1/2 inch) Leaks.....	3-15
12. Distribution Nozzle (1-1/2 inch) Stuck Open or Closed.....	3-16
13. Pressure Regulating Valve Pressure Not Correct.....	3-17
14. Butterfly Valve (L1, L2, B1, B2, or B3) Leaks.....	3-18
15. Butterfly Valve (L1, L2, B1, B2, or B3) Stuck Open or Closed.....	3-19
16. Gate Valve Assembly (4-inch) (S1) Leaks	3-20
17. Gate Valve Assembly (4-inch) (S-1) Stuck Open or Closed.....	3-21
18. Water Meter Assembly Leaks	3-22
19. Water Meter Assembly Will Not Operate	3-23
20. Check Valve Leaks.....	3-24
21. Check Valve Stuck Open or Closed.....	3-25

3-3. TROUBLESHOOTING TABLE

Refer to table 3-1 for Operator Troubleshooting instructions.

Refer to figure 3-1 for component location.

3-3. TROUBLESHOOTING TABLE - cont.

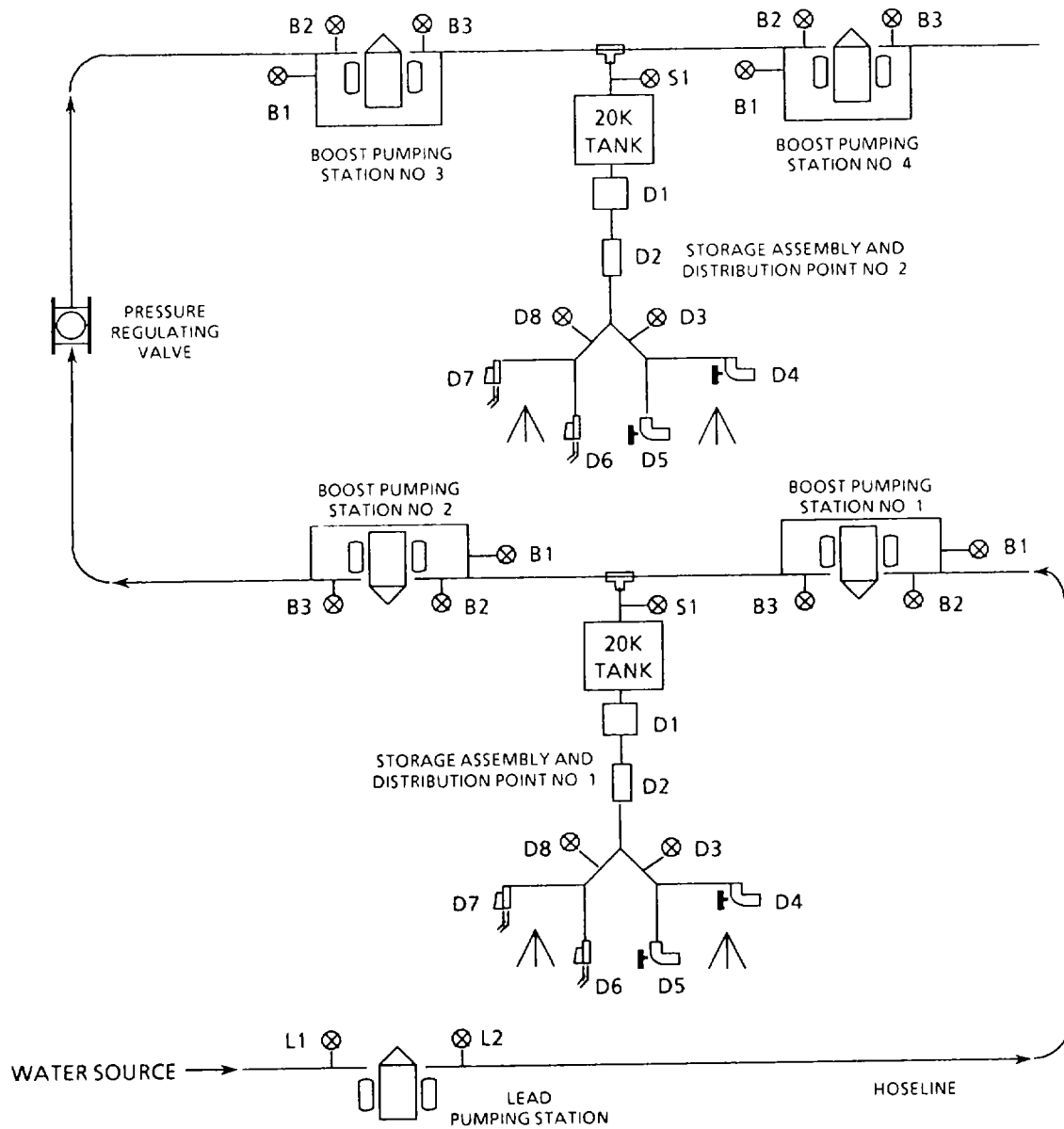

LEGEND

- | | |
|---------------------------|--------------------------|
| B-1 Bypass Valve | D-6 Distribution Nozzle |
| B-2 Suction Valve | D-7 Distribution Nozzle |
| B-3 Discharge Valve | D-8 Discharge Gate Valve |
| D-1 125 Gpm Pump | L-1 Suction Valve |
| D-2 Hypochlorination Unit | L-2 Discharge Valve |
| D-3 Discharge Valve | S-1 Inlet Gate Valve |
| D-4 Elbow Valve | |
| D-5 Elbow Valve | |

Figure 3-1. Water System Control Valves
3-3

Table 3-1 Operator Troubleshooting

WARNING

Be sure to read ALL Warnings in front of manual before troubleshooting

MALFUNCTION 1. NO WATER FLOW TO DISTRIBUTION NOZZLES OR ELBOW VALVES.

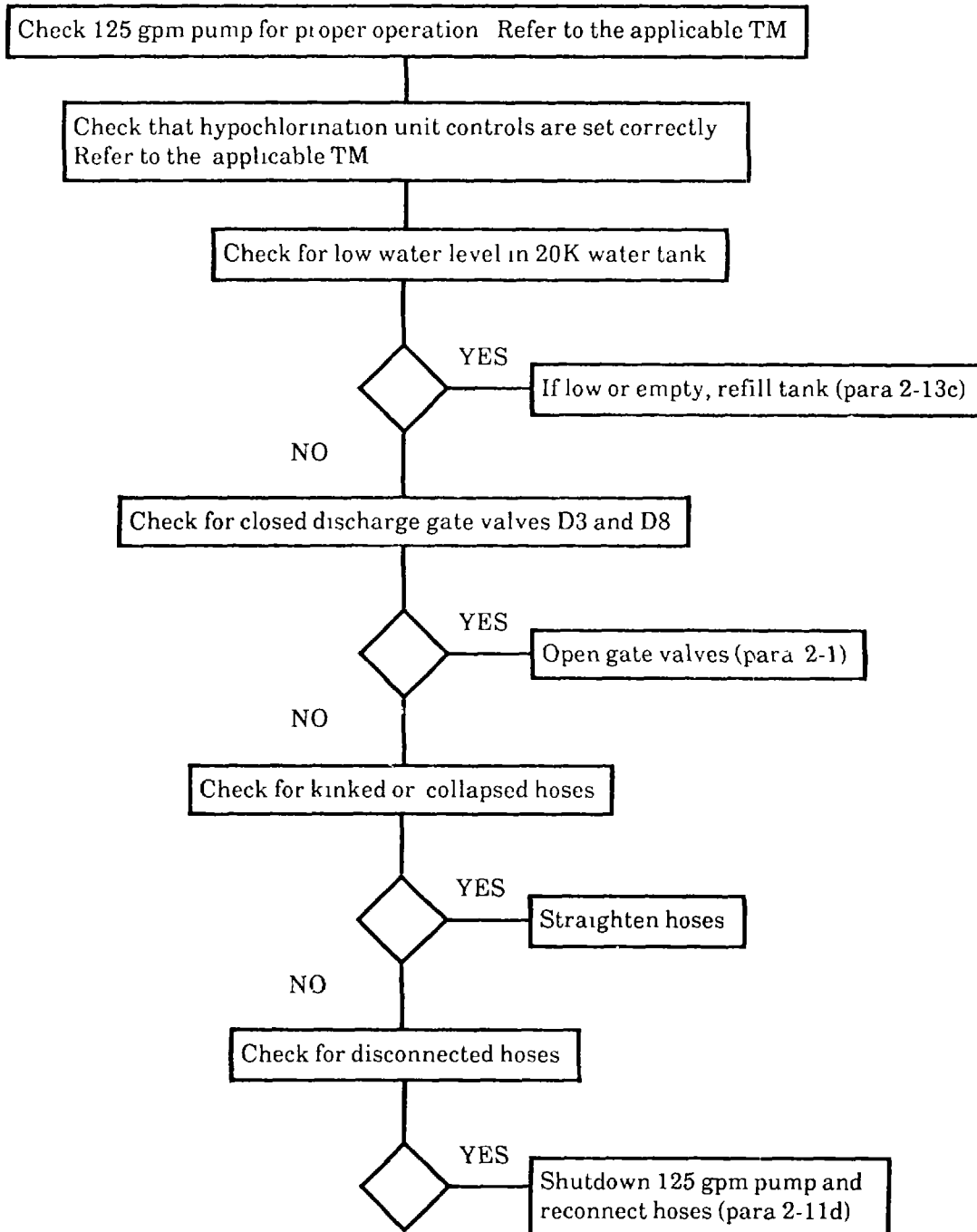

Table 3-1 Operator Troubleshooting

MALFUNCTION 2. LOW WATER PRESSURE TO DISTRIBUTION NOZZLES OR ELBOW VALVES.

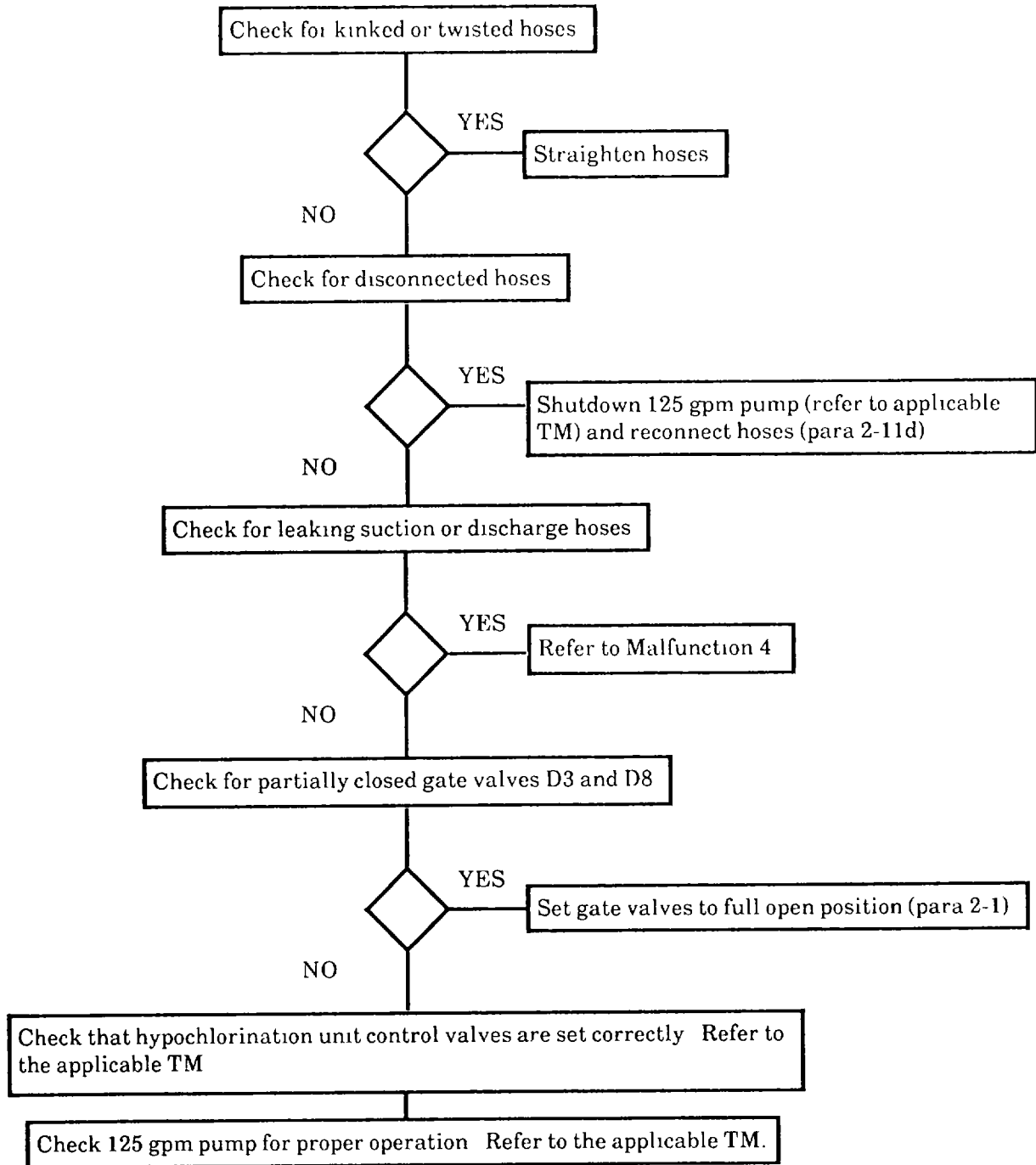

Table 3-1 Operator Troubleshooting - cont.

MALFUNCTION 3. LOW WATER PRESSURE IN MAIN HOSELINE.

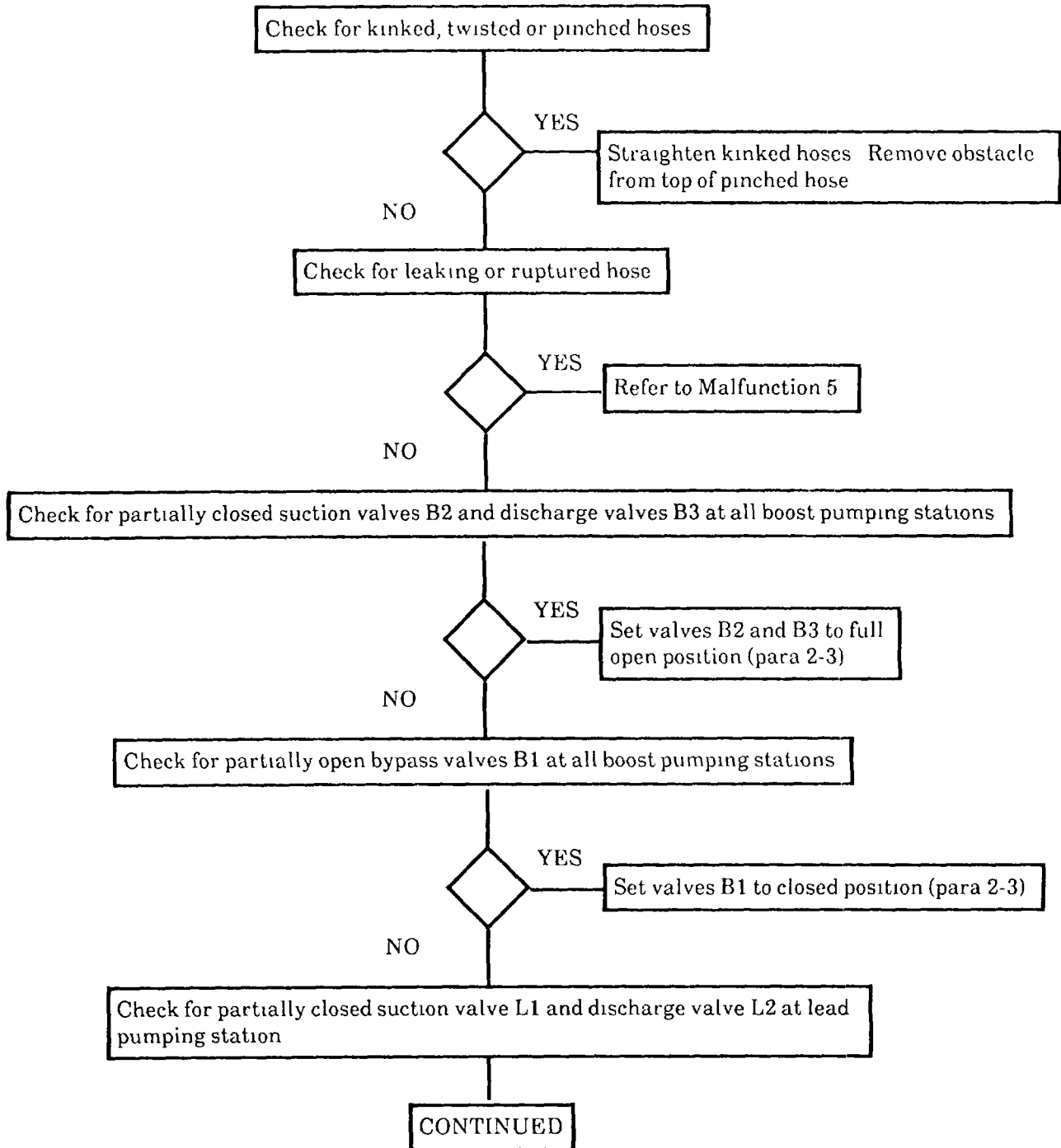

Table 3-1 Operator Troubleshooting - cont.

MALFUNCTION 3. LOW WATER PRESSURE IN MAIN HOSELINE - cont.

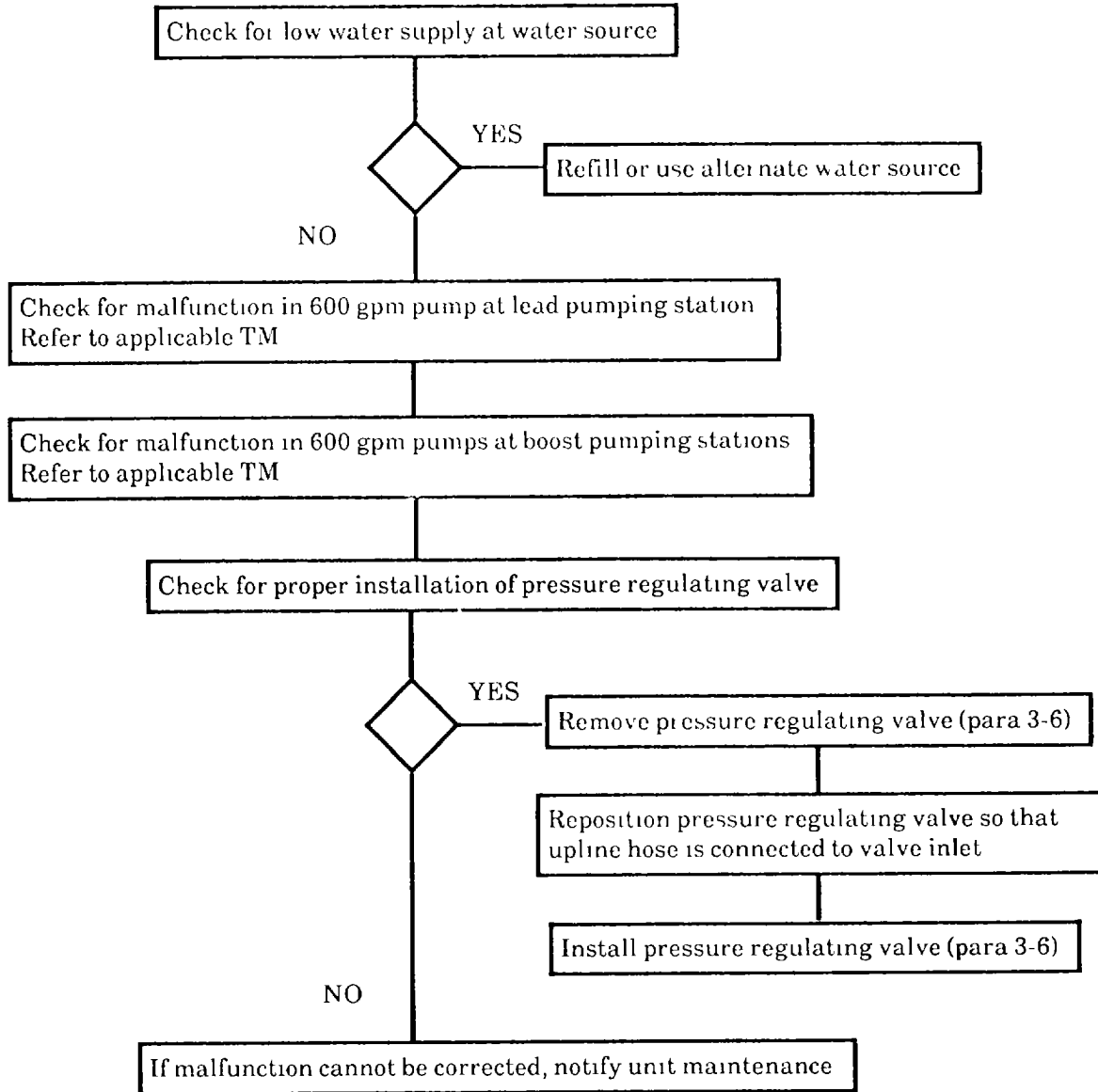

Table 3-1 Operator Troubleshooting cont.

MALFUNCTION 4. DISCHARGE OR SUCTION HOSE LEAKS (DISTRIBUTION POINT).

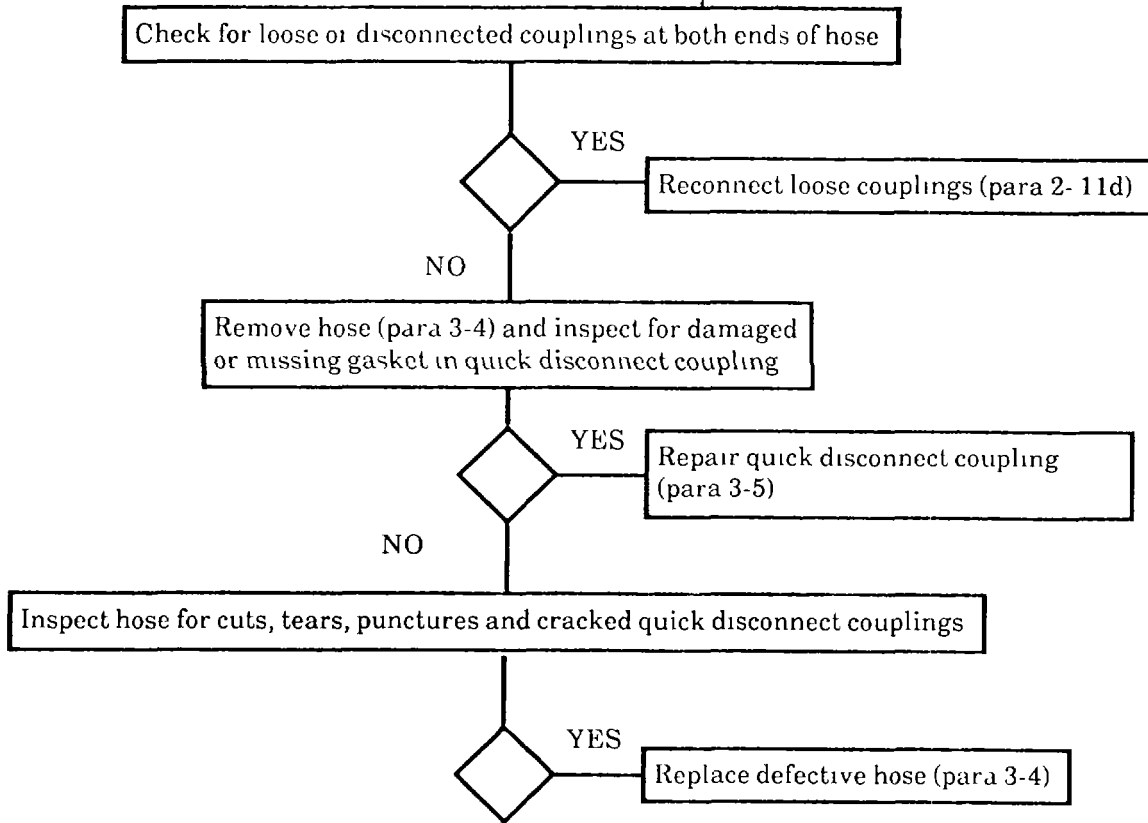

Table 3-1 Operator Troubleshooting - cont.

MALFUNCTION 5. DISCHARGE OR SUCTION HOSE LEAKS (HOSELINE).

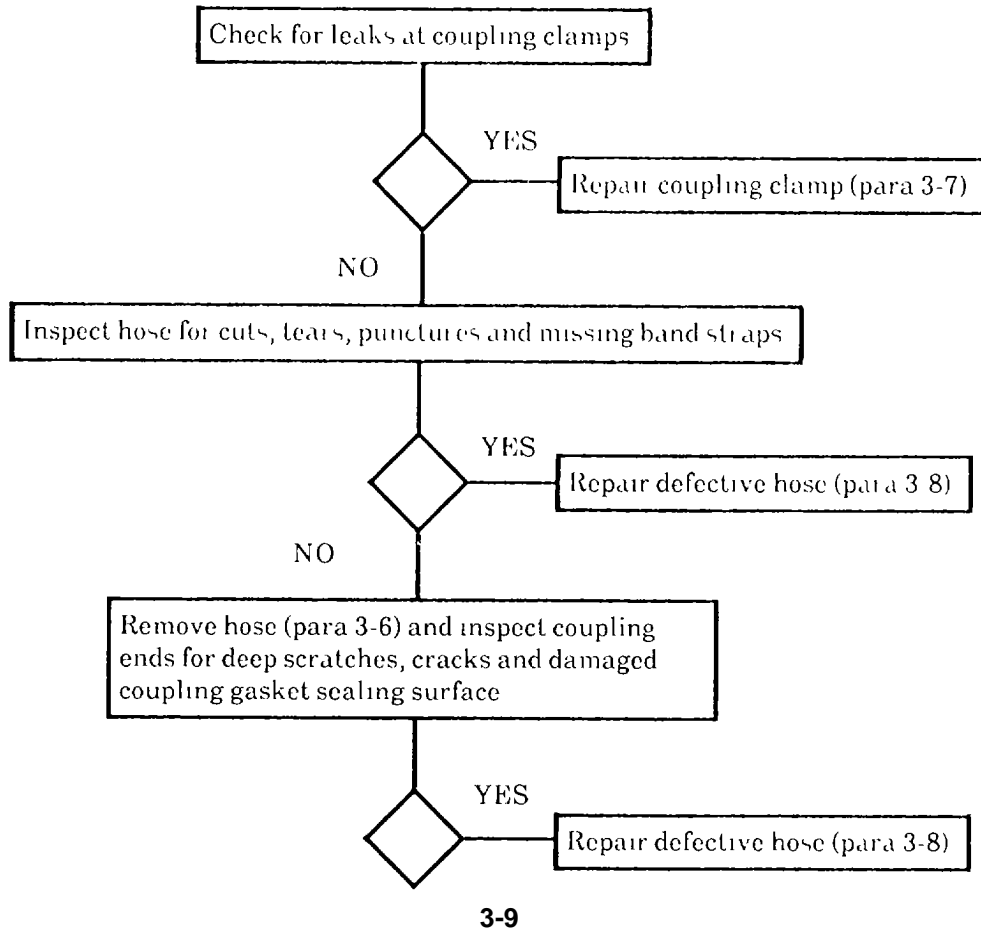

Table 3-1 Operator Troubleshooting - cont.

MALFUNCTION 6. GATE VALVE ASSEMBLY (2-INCH) (D3 OR D8) LEAKS.

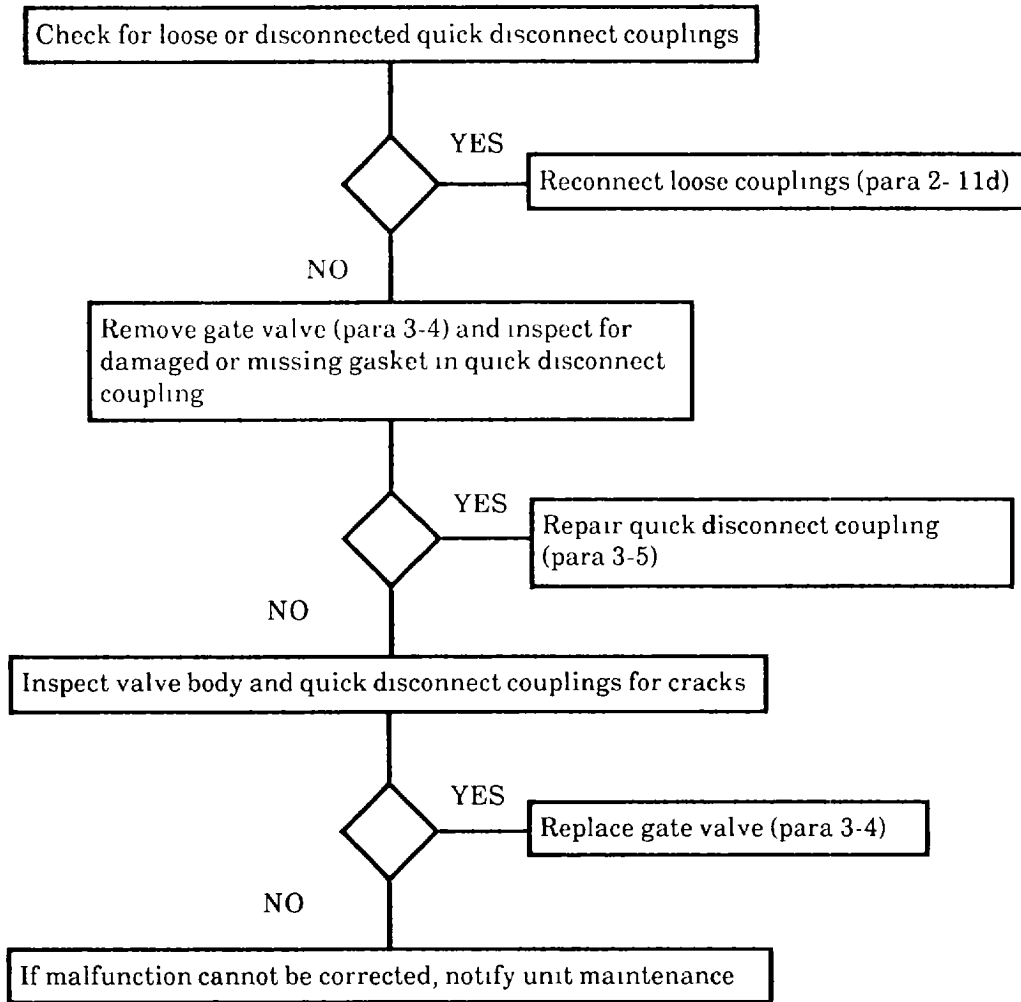

Table 3-1 Operator Troubleshooting - cont

MALFUNCTION 7. GATE VALVE (2-INCH) (D3 OR D8) STUCK OR JAMMED.

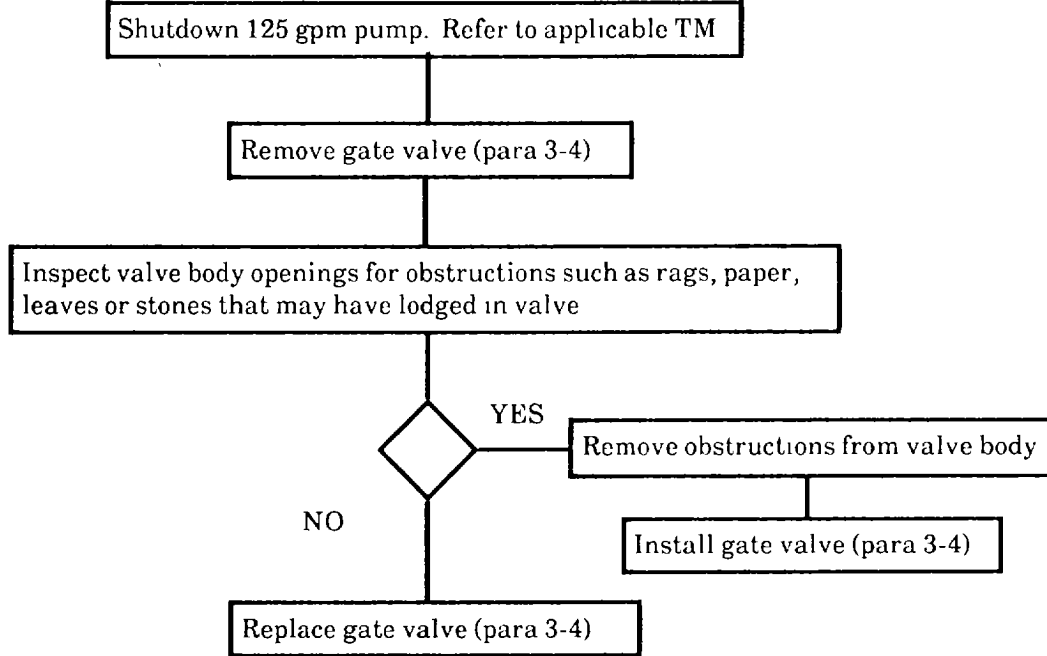

Table 3-1. Operator Troubleshooting- cont.

MALFUNCTION 8. Y FITTING LEAKS (DISTRIBUTION POINT).

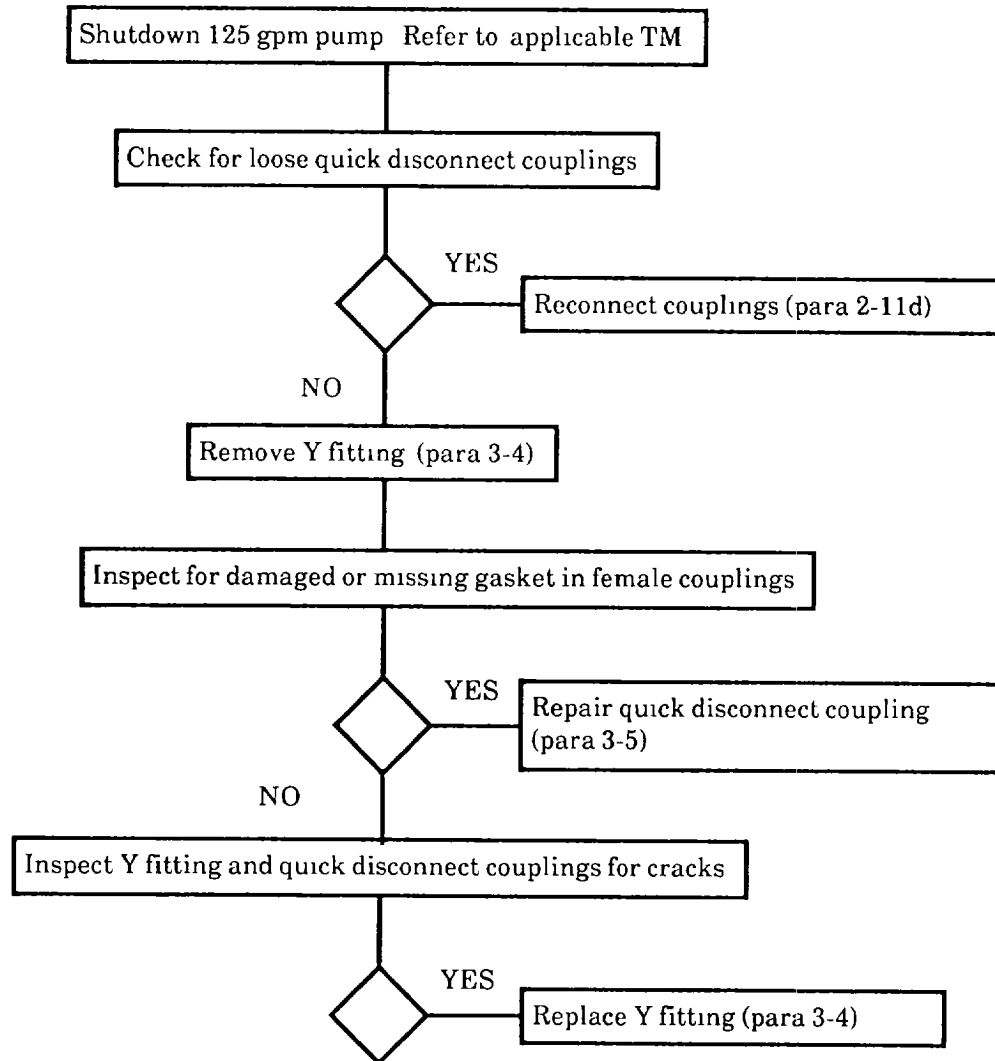

Table 3-1 Operator Troubleshooting - cont.

MALFUNCTION 9. ELBOW VALVE (D4 OR D5) LEAKS.

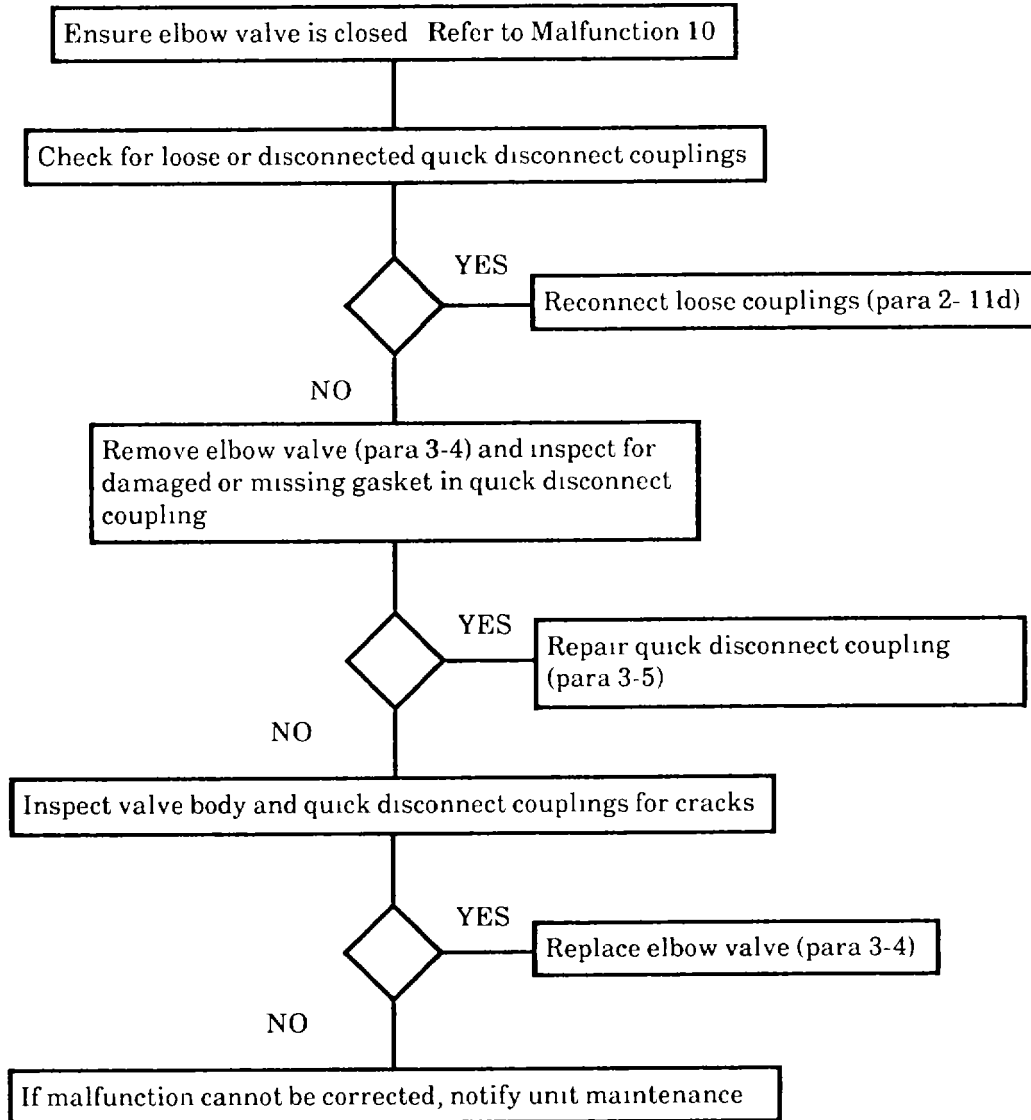

Table 3-1 Operator Troubleshooting - cont.

MALFUNCTION 10. ELBOW VALVE (D4 OR D5) STUCK OR JAMMED.

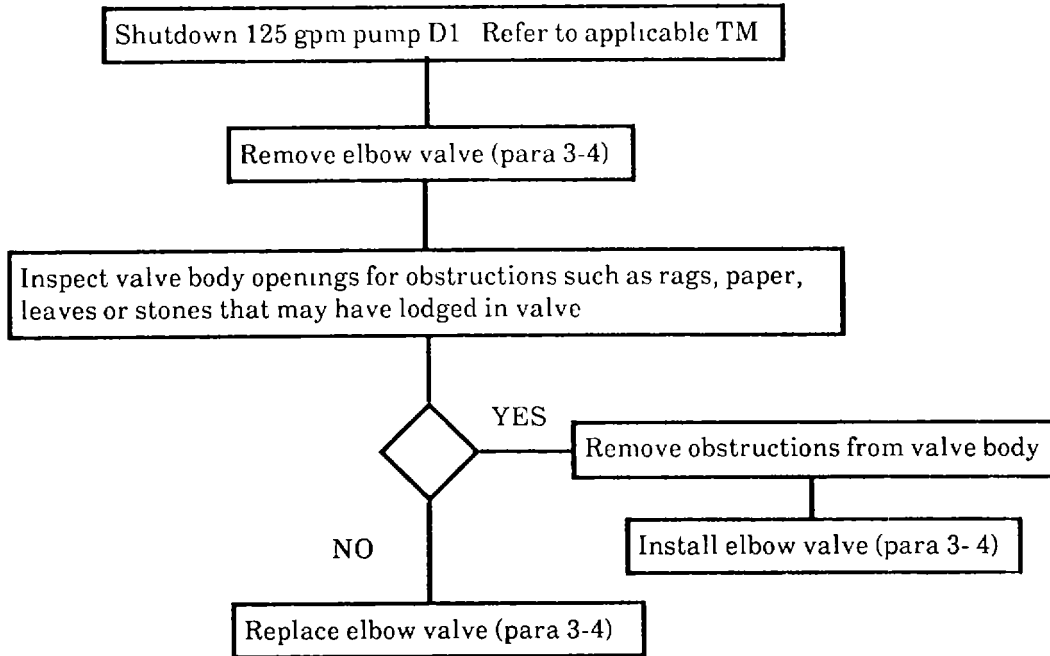

Table 3-1 Operator Troubleshooting - cont.

MALFUNCTION 11. DISTRIBUTION NOZZLE (1-1/2 INCH) LEAKS.

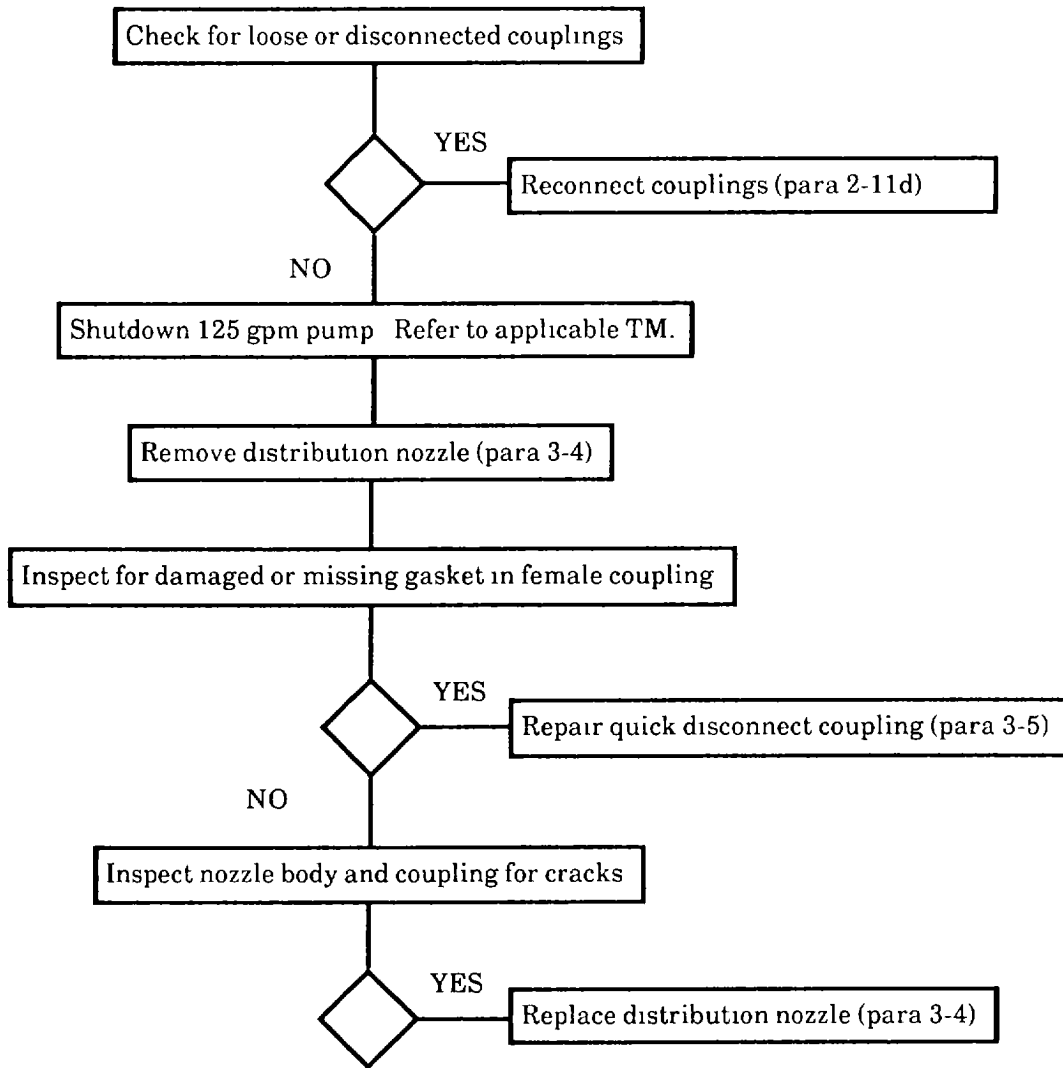

Table 3-1 Operator Troubleshooting - cont.

MALFUNCTION 12. DISTRIBUTION NOZZLE (1-1/2 INCH) STUCK ONEN OR CLOSED.

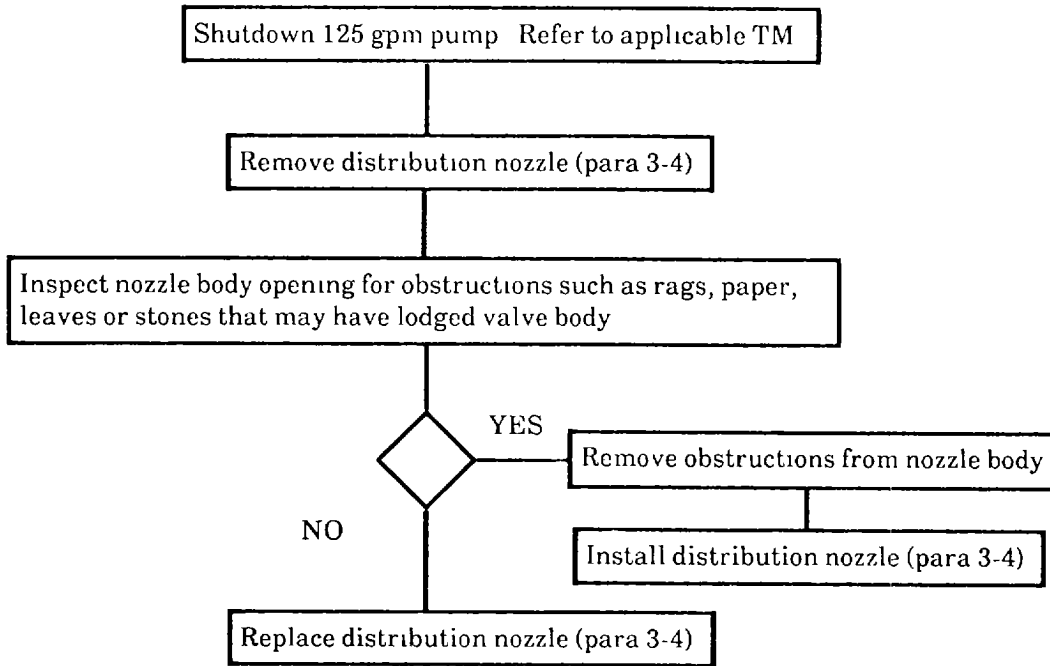

Table 3-1 Operator Troubleshooting- cont.

MALFUNCTION 13. PRESSURE REGULATING VALVE PRESSURE NOT REDUCING PRESSURE.

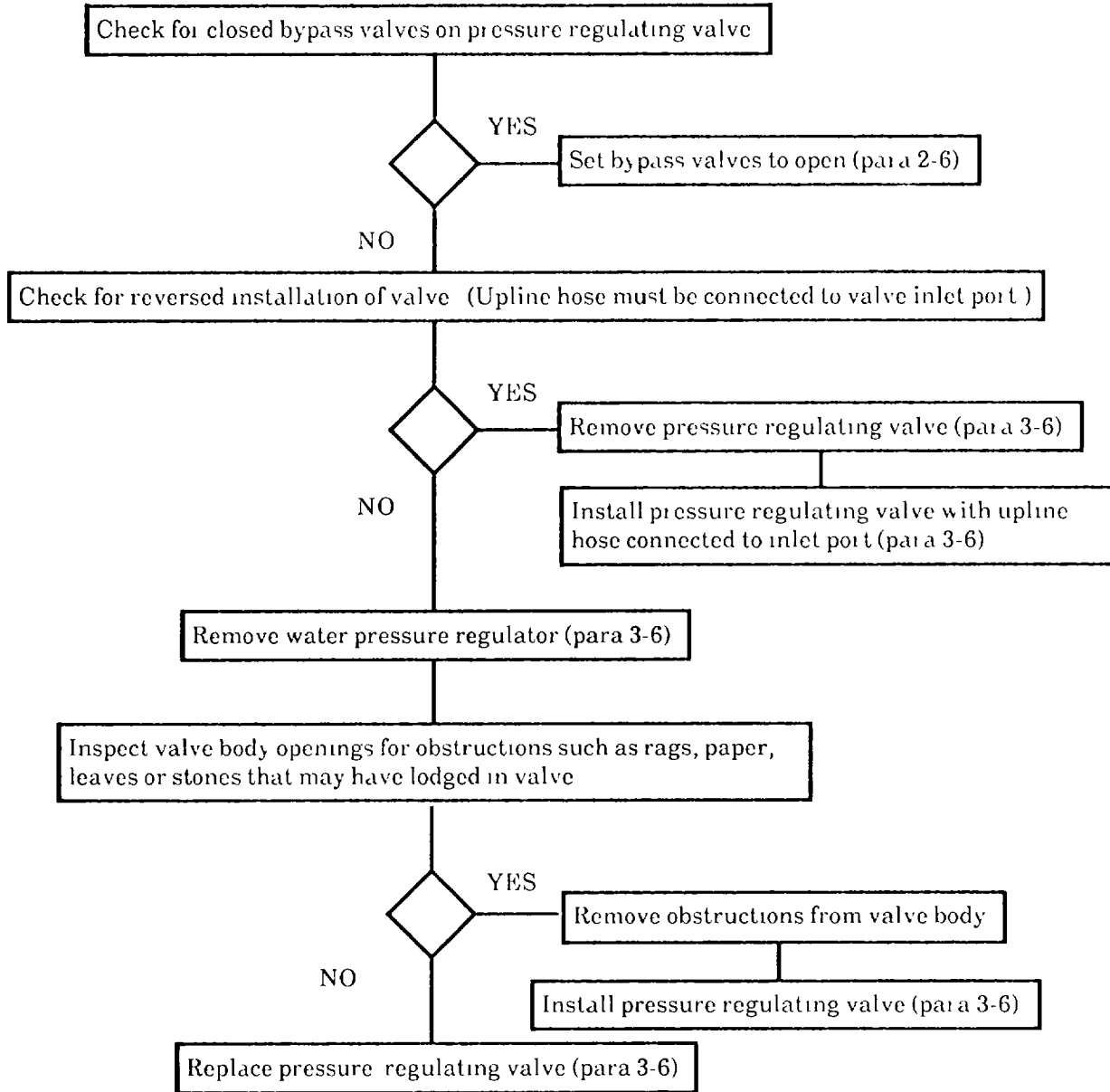

Table 3-1 Operator Troubleshooting - cont.

MALFUNCTION 14. BUTTERFLY VALVE(L1 L2, B1, B2, OR B3) LEAKS.

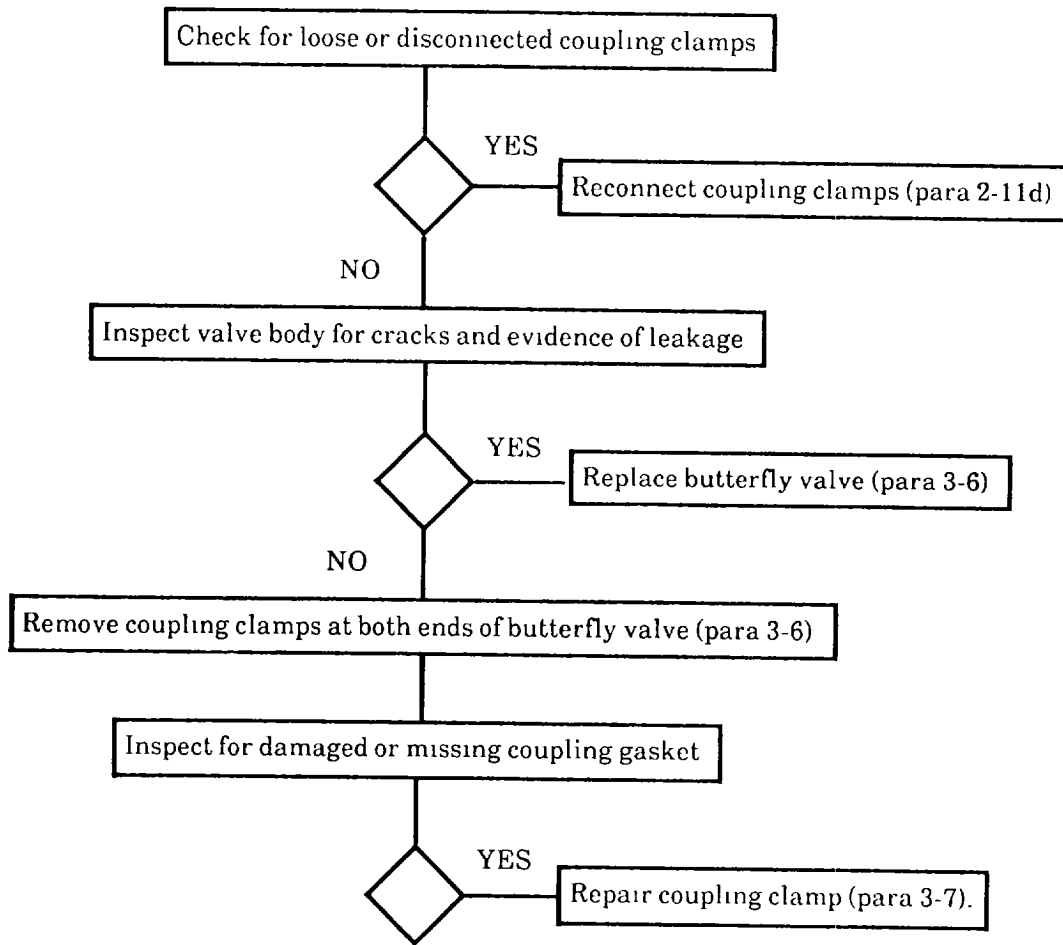

Table 3-1.Operator Troubleshooting-cont.

MALFUNCTION 15. BUTTERFLY VALVE (L1, L2, B1, B2, OR B3) STUCK OPEN OR CLOSED.

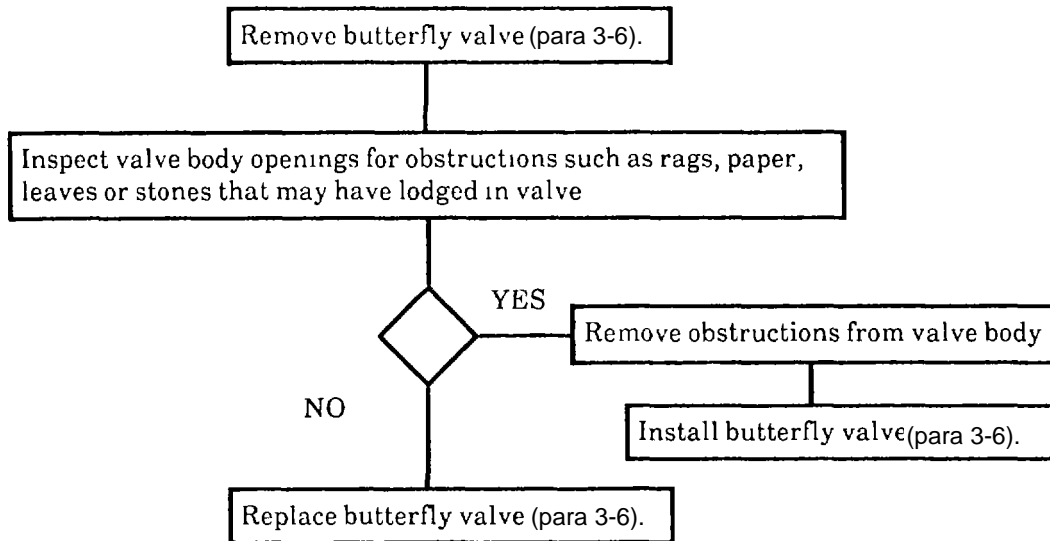

Table 3-1. Operator Troubleshooting-cont.

MALFUNCTION 16. GATE VALVE ASSEMBLY (4-INCH) (S1) LEAKS.

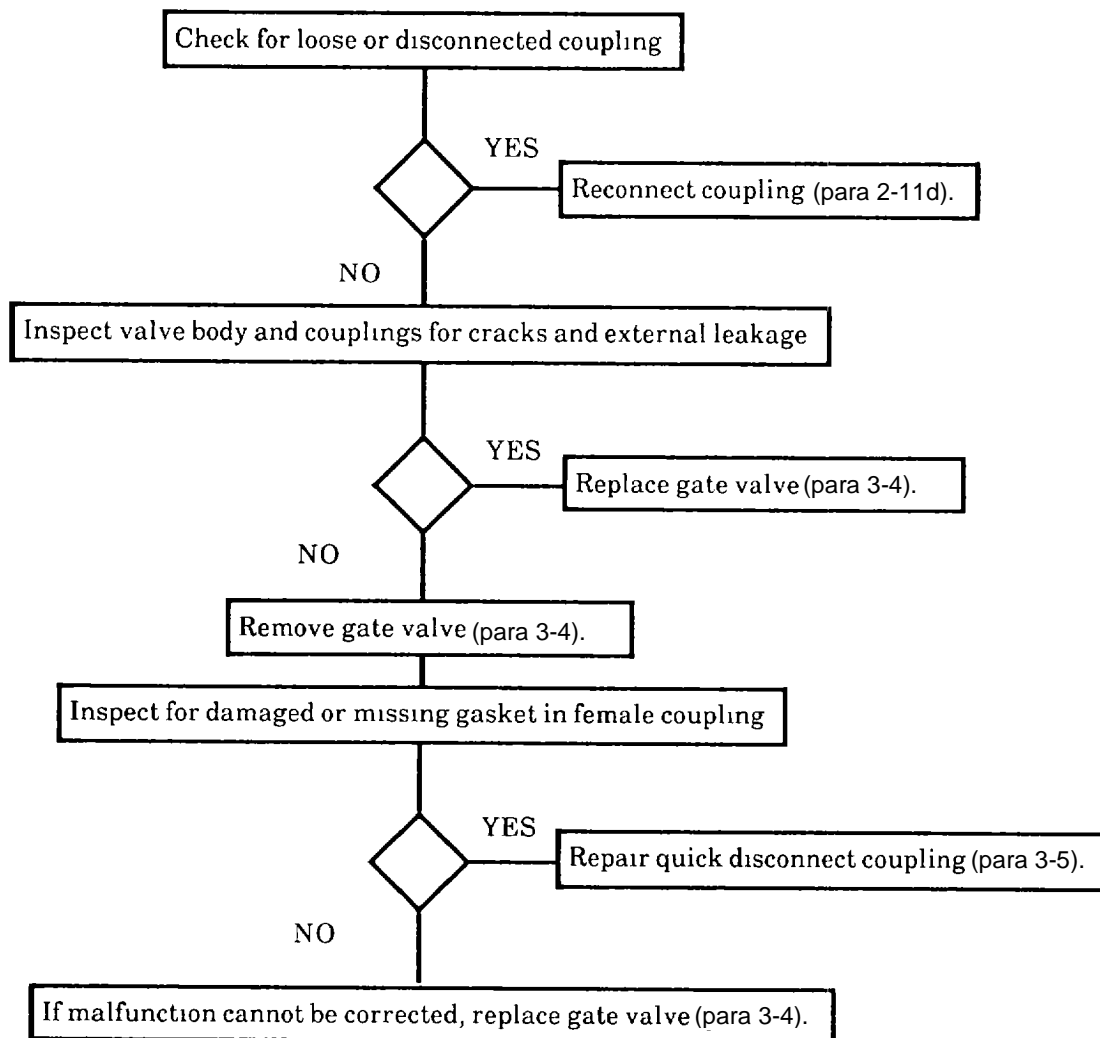

Table 3-1. Operator Troubleshooting-cont.

MALFUNCTION 17. GATE VALVE ASSEMBLY (4-INCH) (S-1) STUCK OPEN OR CLOSED).

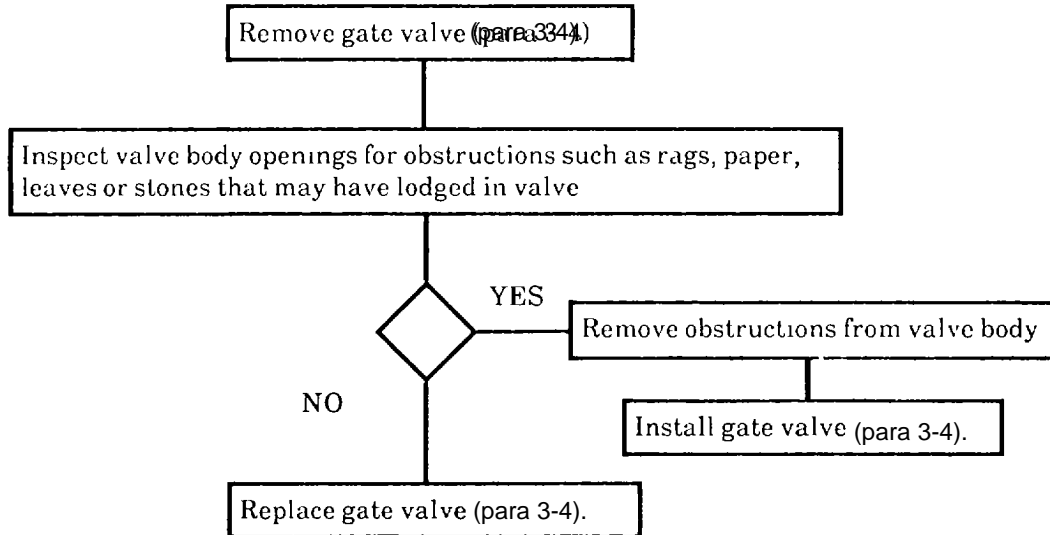

Table 3-1. Operator Troubleshooting-cont.

MALFUNCTION 18. WATER METER ASSEMBLY LEAKS.

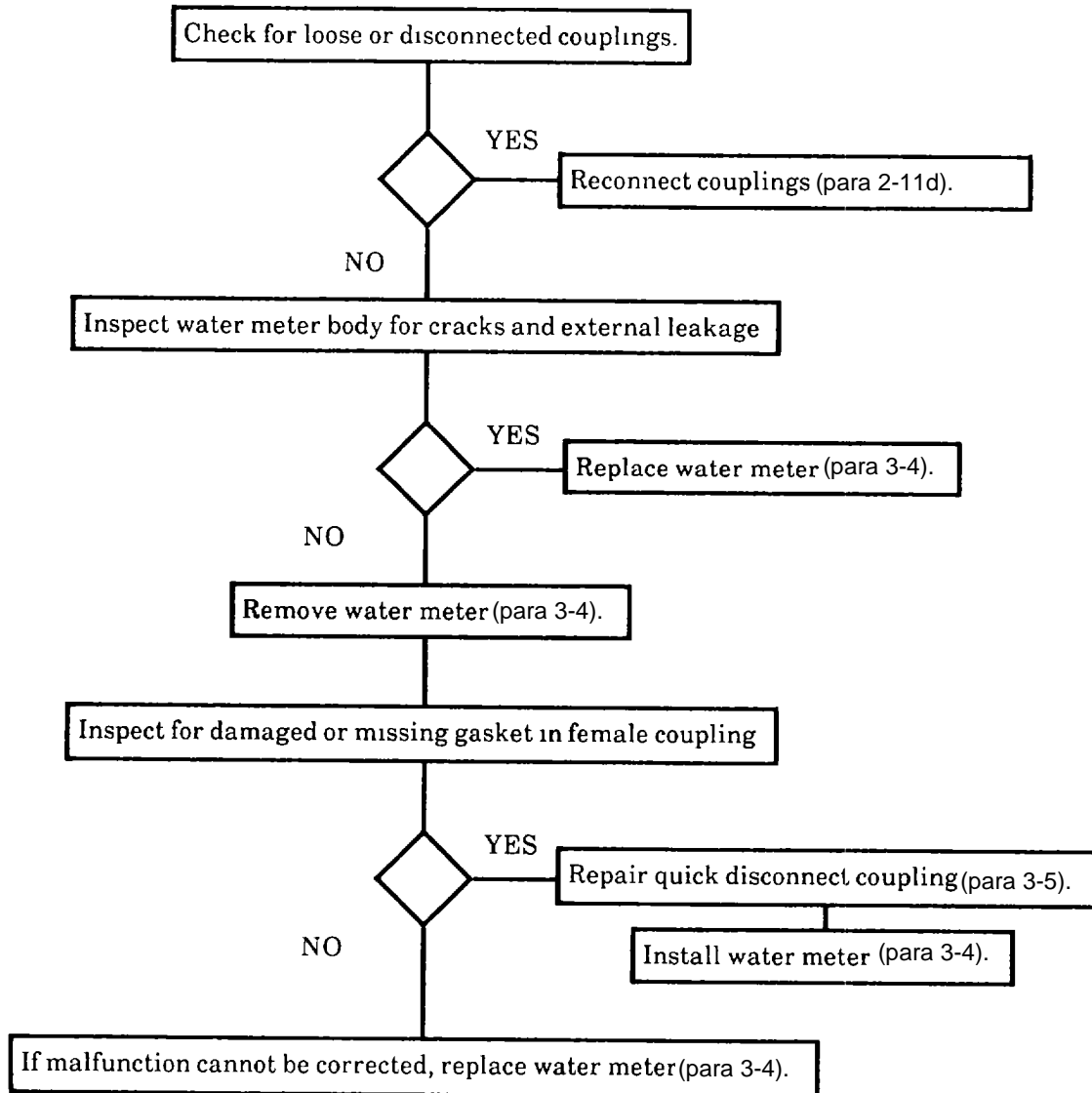

Table 3-1. Operator Troubleshooting-cont.

MALFUNCTION 19. WATER METER ASSEMBLY WILL NOT OPERATE.

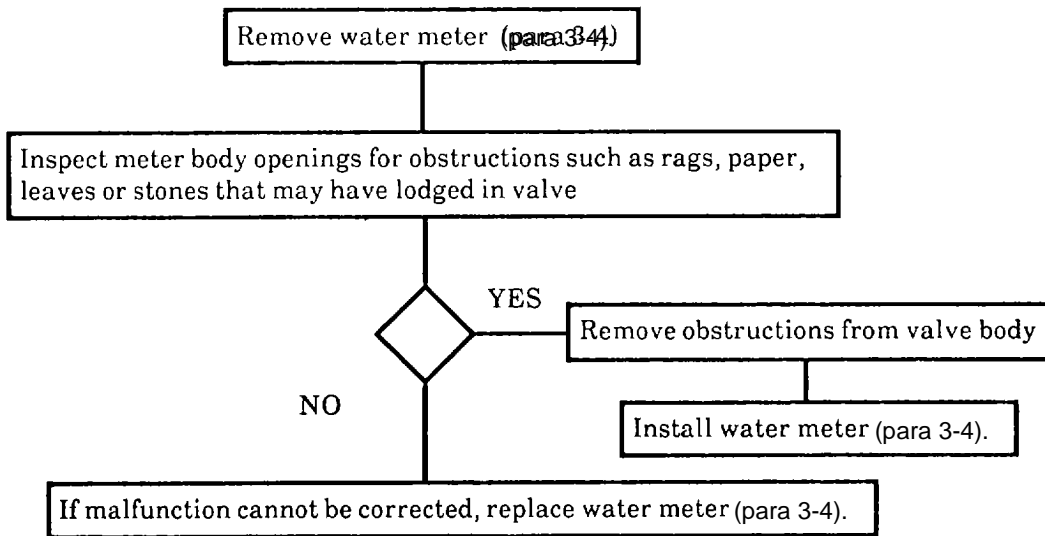

Table 3-1. Operator Troubleshooting-cont.

MALFUNCTION 20. CHECK VALVE LEAKS.

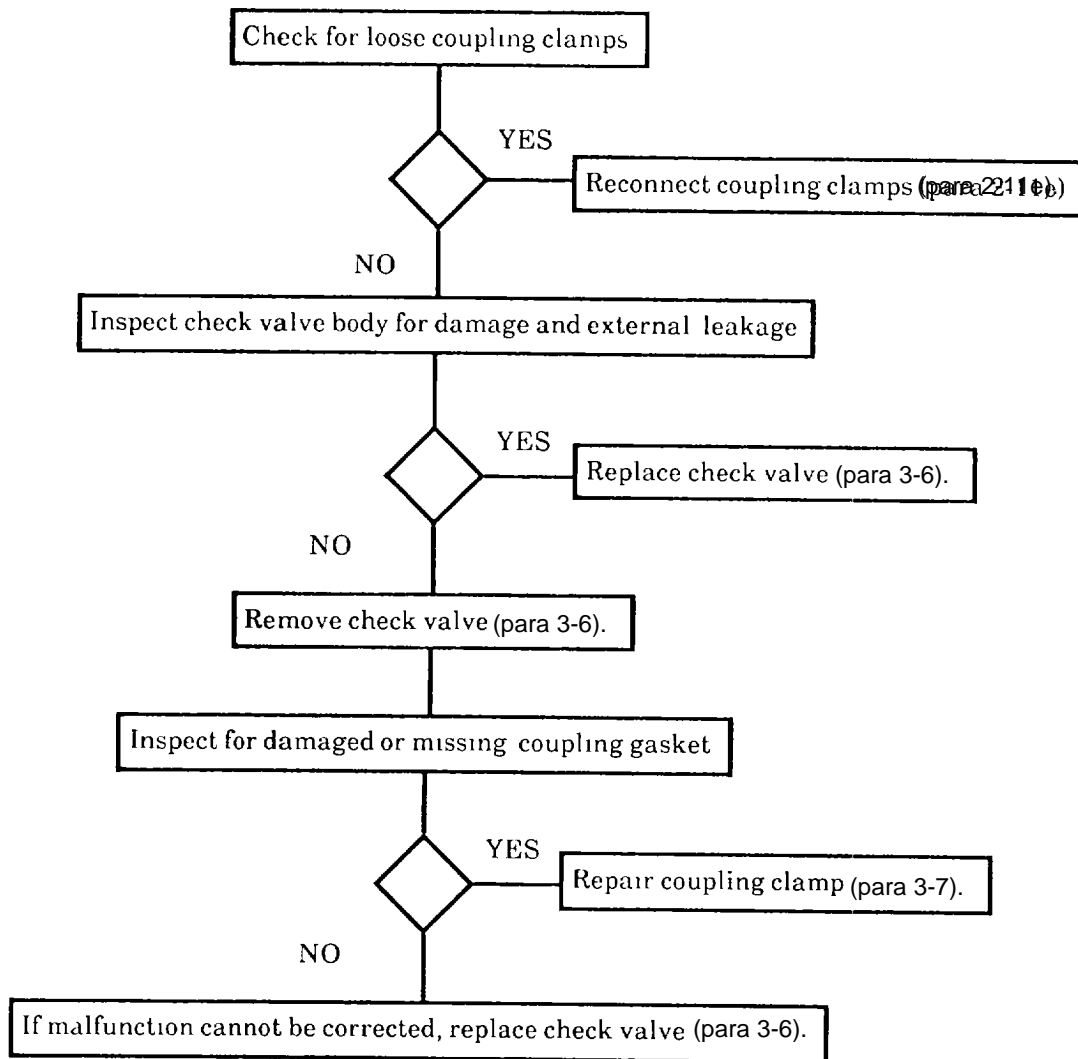
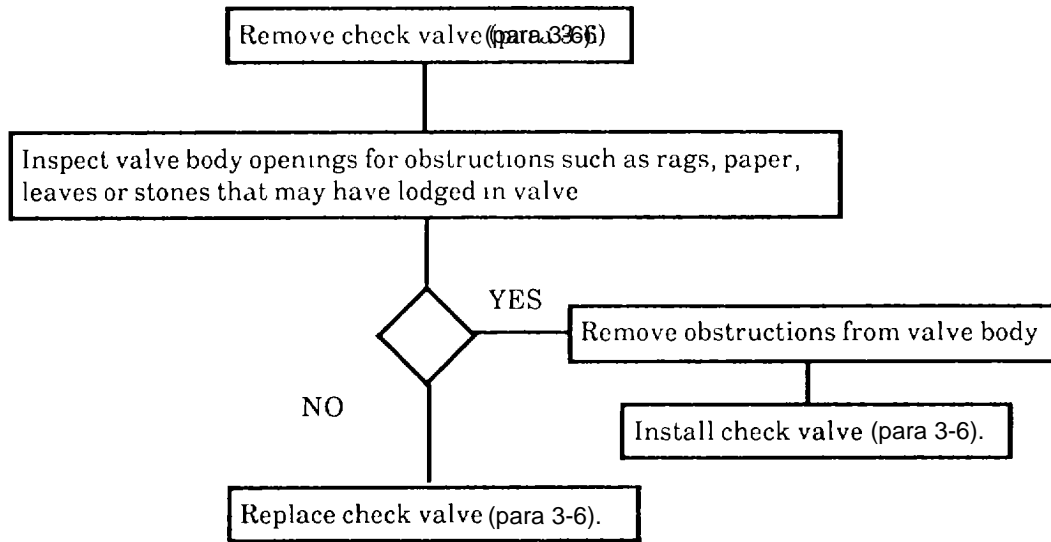

Table 3-1. Operator Troubleshooting-cont.

MALFUNCTION 21. CHECK VALVE STUCK OPEN OR CLOSED.



Section III. OPERATOR MAINTENANCE PROCEDURES

13-4. COMPONENT REPLACEMENT (QUICK DISCONNECT COUPLINGS).

Removal of defective components from the assembled water system is accomplished by disconnecting the coupling at both ends of the component and removing the defective item. Installation of replacement components is performed by positioning the new component in the water system and connect the coupling at both ends of the component

This task consists of: a Removal b. Installation

INITIAL SET-UP:

General Safety Instructions:

Equipment Condition:

Water system shutdown (para 2-13d)

WARNING

To prevent injury to personnel, all water pumps must be shutdown and water pressure relieved from discharge hoses before disconnecting couplings. Cap all open couplings to prevent water system contamination.

NOTE

Replacement of a typical 4-inch gate valve is shown. Replacement of all water system components having quick disconnect couplings is similar.

a. Removal. Refer to figure 3-2.

- (1) Disconnect female coupling (1) from male coupling (2).
- (2) Disconnect female coupling (3) from male coupling (4).
- (3) Remove defective 4-inch gate valve (5) from water system.
- (4) Install cap (6) on male coupling (4).
- (5) Install plug (7) in female coupling (1).

b. Installation. Refer to figure 3-2.

- (1) Remove plug (7) from female coupling (1).
- (2) Remove cap (6) from male coupling (4).
- (3) Position replacement 4-inch gate valve (5) in water system.
- (4) Connect female coupling (1) to male coupling (2).
- (5) Connect female coupling (3) to male coupling (4).
- (6) Startup water system (para 2-13c) and check for leaks at replaced component.

3-4. COMPONENT REPLACEMENT (QUICK DISCONNECT COUPLINGS)-cont.

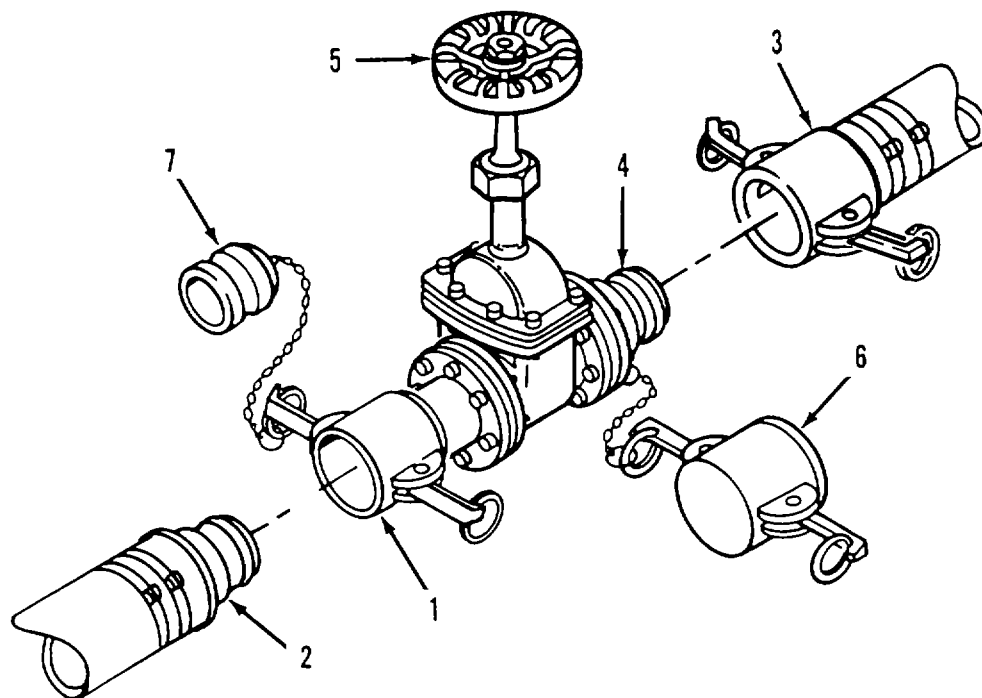

Figure 3-2. Quick Disconnect Component Replacement.

3-5. QUICK DISCONNECT COUPLING REPAIR.

The following instructions are applicable to both female quick disconnect couplings and caps.

This task consists of **a. Removal** **b. Installation**

INITIAL SET-UP:**Equipment Condition:**

Water system shutdown (para 2-13d)

General Safety Instructions:

WARNING

To prevent injury to personnel, all water pumps must be shutdown and water pressure relieved from discharge hoses before disconnecting couplings. Cap or plug all open couplings to prevent water system contamination.

Materials Required:

Wiping rag (Item 2, App E)
Determine gaskets required from the following table

Coupling Size	Gasket
2-inch	(Item 1, App I)
4-inch	(Item 2, App I)

NOTES

- Repair of a typical 4-inch female coupling and cap is shown. Repair of 2-inch couplings and caps is similar.
 - Replacement gaskets are supplied in the accessory kit.
- a. Removal. Refer to figure 3-3.
- (1) Disconnect female coupling (1) from water system (para 2-11d).
 - (2) Pull gasket (2) from interior of female coupling (1).
- b. Installation. Refer to figure 3-3.
- (1) Using clean wiping rag, remove grit, sand, and dirt from gasket seat inside female coupling (1).
 - (2) Position replacement gasket (2) in female coupling (1).
 - (3) Press gasket (2) into gasket seat inside female coupling (1). There will be no ripples or bumps in gasket material when gasket is properly installed.
 - (4) Connect female coupling (1) to water system (para. 2-11d).
 - (5) Startup water system (para 2-13c) and test female coupling (1) for leaks.

13-5. QUICK DISCONNECT COUPLING REPAIR-cont.

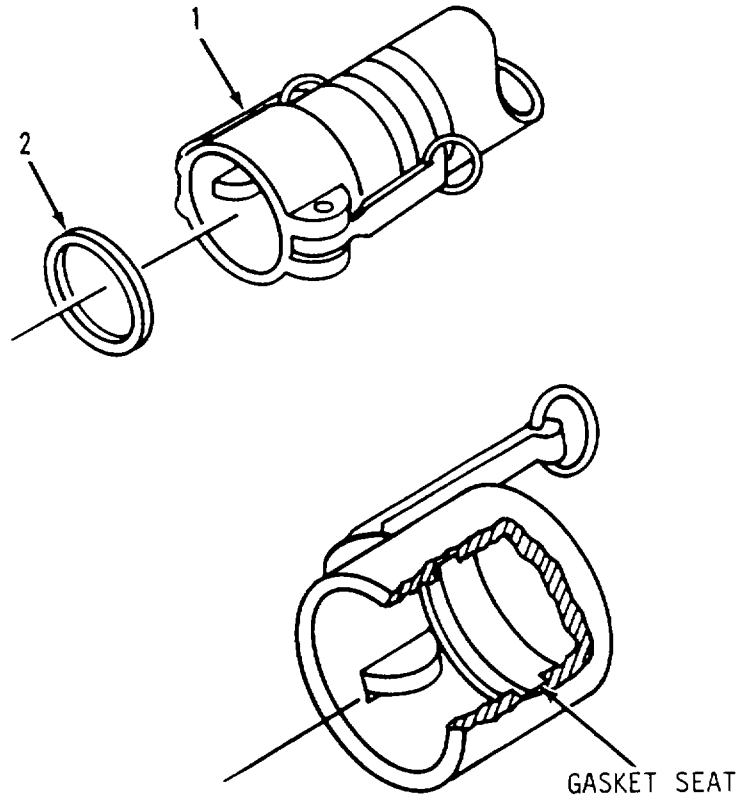

Figure 3-3. Quick Disconnect Repair.

3-6. COMPONENT REPLACEMENT (COUPLING CLAMPS).

Removal of defective components from the assembled water system is accomplished by removing the coupling clamp at both ends of the component and removing the defective item. Installation of replacement components is performed by positioning the new component in the water system and installing coupling clamps at both ends of the component.

This task consists of a. Removal b. Installation

INITIAL SET-UP:

Personnel Required:

Two

General Safety Instructions:

WARNING

To prevent injury to personnel, all water pumps must be shutdown and water pressure relieved from discharge hoses before disconnecting coupling clamps. Cap all open couplings to prevent water system contamination.

Equipment Condition:

Water system shutdown (para 2-13d)

Tools:

Hammer (Item 5, App B)
Punch (Item 6, App B)
Assembly Tool (Accessory Kit)

Material/Parts:

Lubricant (Item 3, App E)

NOTE

Replacement of a typical 6-inch butterfly valve is shown. Replacement of all water system components with grooved pipe couplings is similar.

a. Removal. Refer to figure 3-4.

- (1) Install assembly tool (1) on coupling clamp (2). Push assembly tool handle to the closed position.
- (2) Using a punch and hammer, drive out locking pin (3) from coupling clamp (2).
- (3) Pull handle of assembly tool (1) away from coupling clamp (2) and remove tool.
- (4) Open and remove coupling clamp (2) from hose (4) and butterfly valve (5).
- (5) Separate hose (4) from butterfly valve (5) and remove coupling gasket (6).
- (6) Repeat steps (1) through (5) for coupling clamp (7).
- (7) Remove defective butterfly valve (5) from water system.

3-6. COMPONENT REPLACEMENT (COUPLING CLAMPS)-cont.

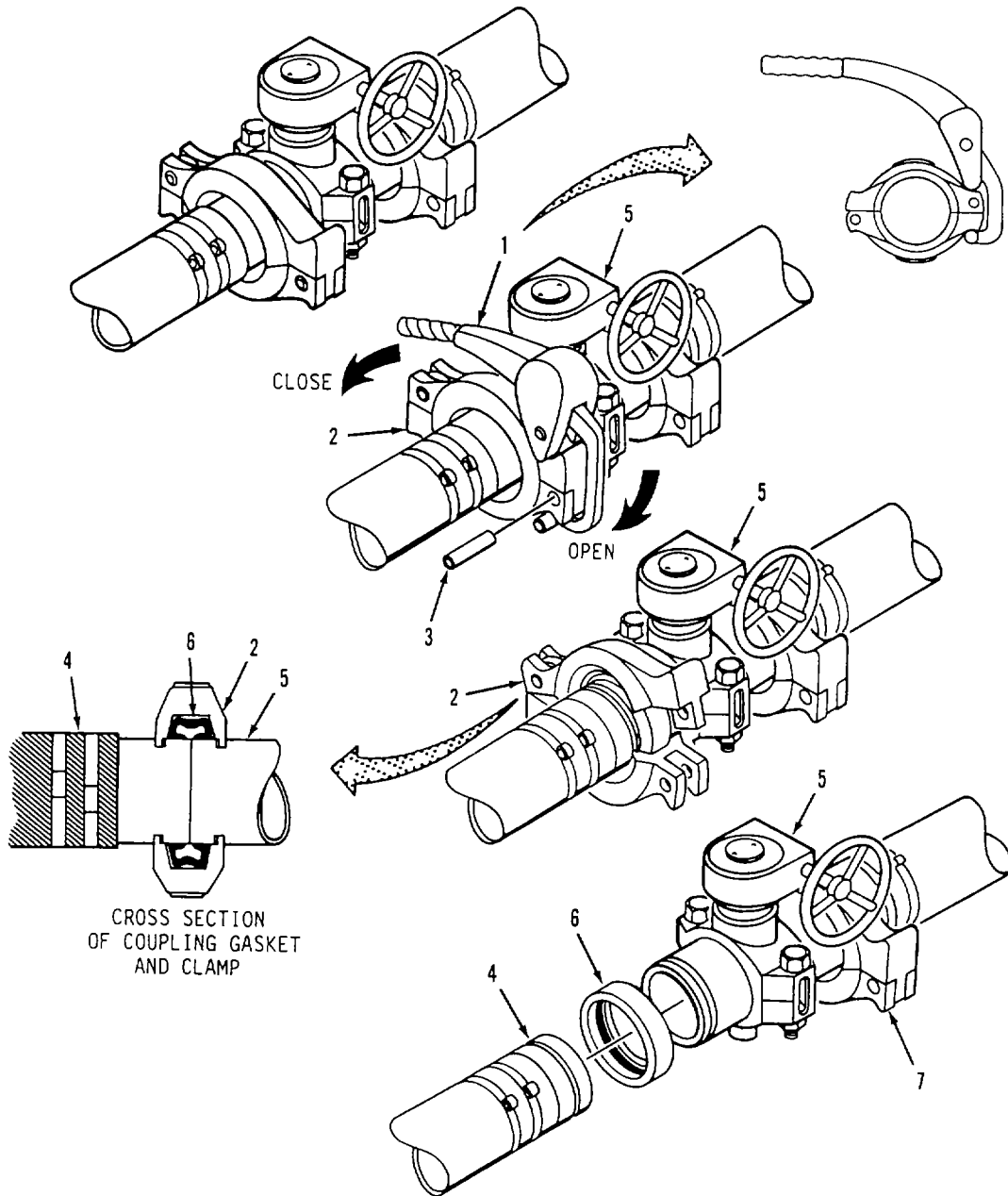

Figure 3-4. Coupling Clamp Component Removal.

3-6. COMPONENT REPLACEMENT(COUPLING CLAMPS)-cont.**WARNING**

To prevent contamination of water system and damage to the equipment, use care when installing coupling clamps to avoid getting dirt, sand and debris on sealing surfaces of mating components Do not use petroleum based lubricants on coupling gaskets

CAUTION

To prevent leaks and ensure water tight connections, make sure coupling gaskets are installed properly

b. Installation. Refer to figure 3-5.

- (1) Position replacement butterfly valve (5) in water system.
- (2) Apply a thin, even coating of lubricant to coupling gasket (6).
- (3) Slide gasket (6) over end of coupling on hose (4).
- (4) Align and mate ends of couplings on hose (4) and butterfly valve (5).
- (5) Slide coupling gasket (6) over ends of couplings on hose (4) and butterfly valve (5) Make sure gasket is positioned as shown.
- (6) Position one half of coupling clamp (2) over coupling gasket (6) and into grooves of couplings on hose (4) and butterfly valve (5).
- (7) Close other half of coupling clamp (2) over coupling gasket (6) while aligning clamp with grooves of couplings on hose (4) and butterfly valve (5) . Hold clamp in position.
- (8) Place assembly tool (1) on coupling clamp (2) . Move handle to closed position. As clamp is squeezed together, make sure coupling gasket (6) is not pinched under clamp. Assembly tool will lock in closed position when clamp is correctly seated.

NOTE

Locking pin must be installed with splines (ridges) pointing out from coupling clamp.

- (9) Using hammer, drive locking pin (3) through locking pin holes in both halves of coupling clamp (2). Make sure locking pin is sticking through both halves of clamp.
- (10) Pull handle of assembly tool (1) to open position, and remove tool from coupling clamp (2).
- (11) Repeat steps (2) through (10) for coupling clamp (7).
- (12) Startup water system (para 2-13c) and check for leaks at replaced component

3-6. COMPONENT REPLACEMENT (COUPLING CLAMPS)- cont.

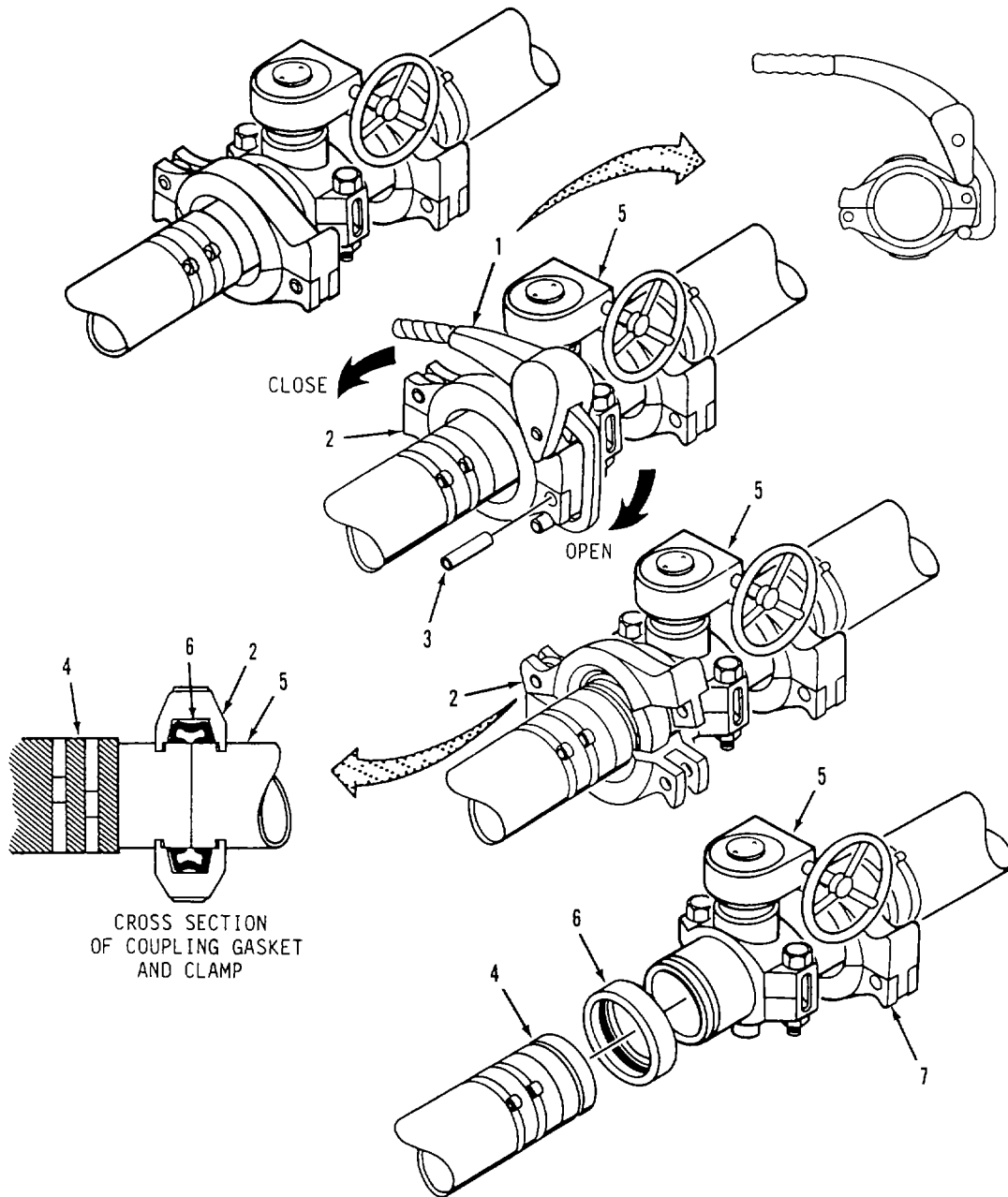

Figure 3-5. Coupling Clamp Component Installation.

3-7. COUPLING CLAMP REPAIR.

This task consists of a. Removal b. Installation

INITIAL SET-UP:

Equipment Condition:

- Water system shutdown (para 2-13d)
- Coupling clamp removed (para 3-6)

Materials Required:

Determine gaskets and pins required by clamp size

General Safety Instructions:

WARNING

To prevent injury to personnel, all water pumps must be shutdown and water pressure relieved from discharge hoses before disconnecting couplings Cap or plug all open components to prevent water system contamination

Clamp Size	Gasket	Pin
4-inch	(Item 3, App I)	(Item 4, App I)
6-inch	(Item 5, App I)	(Item 6, App I)

NOTE

Repair of coupling clamps is limited to replacement of the coupling gasket and pin.

- a. Removal. Remove coupling clamp from installed component (para 3-6a).
- b. Installation. Install coupling clamp using new coupling gasket and pin (para 3-6b).

3-8. HOSE(6-INCH) REPAIR.

This task consists of: **Repair**

INITIAL SET-UP:

Equipment Condition :

Water system shutdown (para 2-13d)

Tools:

Hose Repair Kit (supplied with system)

General Safety Instructions:

WARNING

To prevent injury to personnel, all water pumps must be shutdown and water pressure relieved from discharge hoses before disconnecting couplings. Cap or plug all open components to prevent water system contamination.

Repair. Refer to figure 3-6.

- (1) Install hose clamps (1 and 2) about 3-feet upline and downline from damaged section of hose (β). Tighten hose clamps until hose is pinched closed.

CAUTION

To ensure hose does not leak after repair, mark and cut hose squarely. Do not leave ragged or uneven edges.

- (2) Cut out damaged section of hose (3) with knife. If leak is caused by a small puncture, cut hose at puncture.
- (3) Inspect inside of hose ends (4 and 6) for damage. Cut hose ends back again, as required, to ensure all damaged hose material is removed.
- (4) Drain hose ends (4 and 6) and allow to dry.

CAUTION

If it is necessary to pound adapter into hose end, place a wood block over sealing face of adapter to prevent damage to adapter.

- (5) Insert one end of adapter (5) into hose end (4). Push adapter into hose until hose end contacts shoulder of adapter as shown.

CAUTION

To prevent damage to hose, do not pound adapter into remaining hose end.

- (6) Insert other end of adapter (5) into hose end (6). Push adapter into hose until hose end contacts shoulder of adapter as shown.
- (7) Position three clamp sections (7) around hose end (4) and adapter (5). Make sure clamp sections mate with groove in adapter as shown.
- (8) Install three bolts (9) and nuts (8) to secure clamp sections (7) to adapter (5).

3-8. HOSE (6-INCH) REPAIR.

(9) Repeat steps (7) and (8) to install repair clamp (10) on hose end (6).

(10) Startup water system (para 2-13c) and check repaired section of hose for leaks.

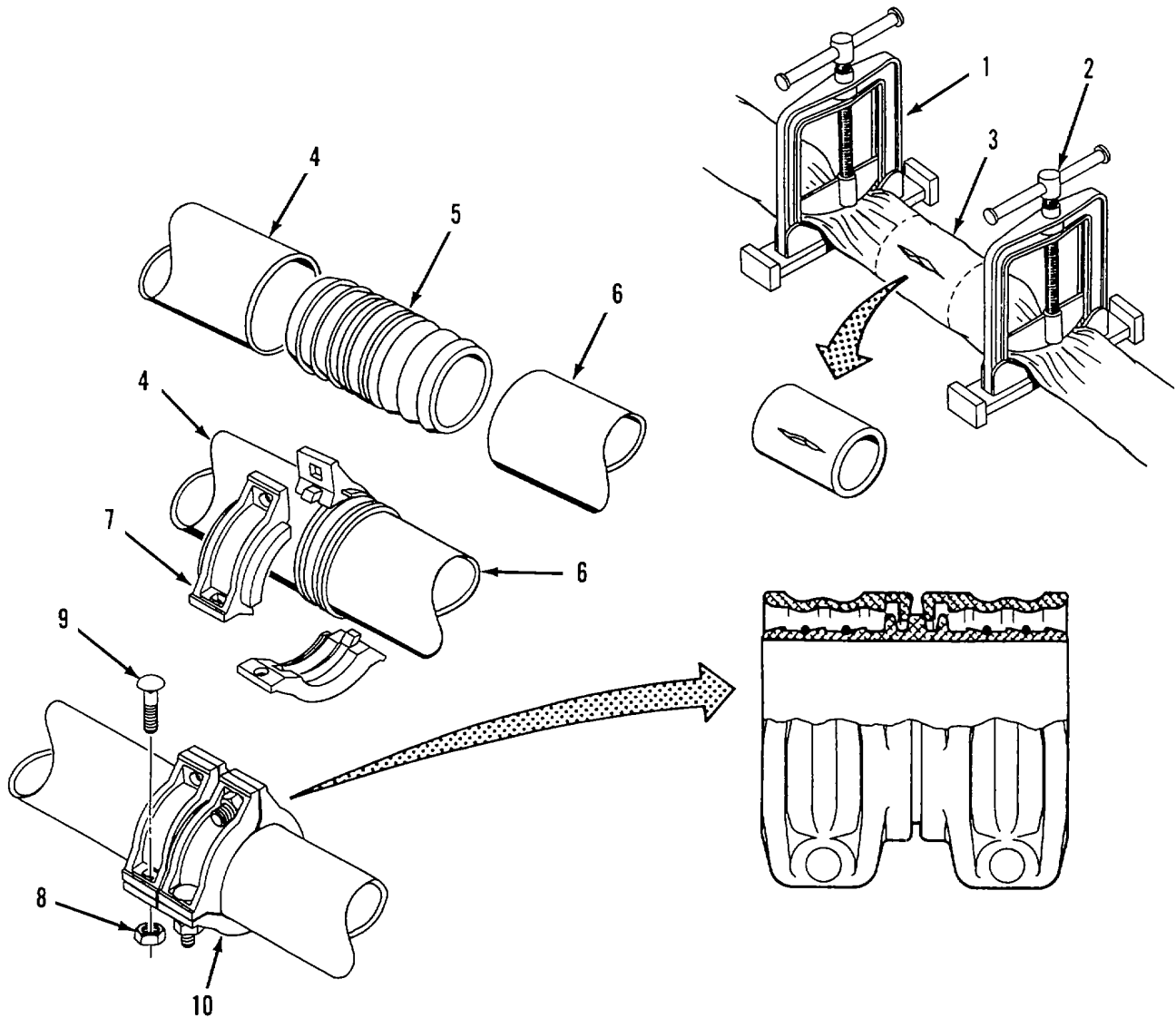

Figure 3-6. Hose Repair.

CHAPTER 4

UNIT MAINTENANCE INSTRUCTIONS

Section I.	Repair Parts and Special Tools List	4-2
4-1.	Common Tools and Equipment.....	4-2
4-2.	Special Tools, TMDE and Support Equipment.....	4-2
4-3.	Repair Parts	4-2
Section II.	Service Upon Receipt	4-2
4-4.	Siting.....	4-2
4-5.	Shelter Requirements.....	4-2
4-6.	Checking Unpacked Equipment.....	4-3
Section III.	Unit Troubleshooting Procedures	4-4
4-7.	Introduction.....	4-4
4-8.	Troubleshooting.....	4-4
4-9.	Malfunction Index.....	4-4
Section IV.	Unit Maintenance Procedures	4-21
4-10.	General.	4-21
4-11.	Personal Safety.....	4-21
4-12.	Proper Equipment.....	4-21
4-13.	Distribution Point Maintenance	4-21
4-14.	Elbow Valve Repair.....	4-22
4-15.	Gate Valve (2-inch) Repair	4-24
4-16.	Distribution Nozzle (1 ½-inch) Repair.....	4-28
4-17.	Suction and Discharge Hose Repair.....	4-33
4-18.	Water Meter Assembly Repair.....	4-38
4-19.	Nozzle Stand Repair.....	4-41
4-20.	Storage Assembly Maintenance.....	4-44
4-21.	Gate Valve (4-inch) Repair	4-44
4-22.	Suspension Assembly Maintenance.....	4-49
4-23.	Storage Chest Repair.....	4-50
4-24.	Sling Assembly Repair.....	4-54
4-25.	Flaking Box Assembly Maintenance	4-56
4-26.	Flaking Box Repair.....	4-56
4-27.	Pressure Regulating Valve Repair.....	4-58
4-28.	Suction Hose Repair.....	4-70
4-29.	Y-Connector Repair.....	4-70
4-30.	Pumping Station Repair.....	4-74
4-31.	Butterfly Valve Repair.....	4-74
Section V.	Preparation for Storage or Shipment	4-78
4-32.	Security Procedures	4-78
4-33.	Administrative Storage	4-78

Section I. REPAIR PARTS AND SPECIAL TOOLS LIST

4-1. COMMON TOOLS AND EQUIPMENT.

For authorized common tools and equipment, refer to the Modified Table of Organization and Equipment (MTOE), CTA 50-970 or CTA 8-100, applicable to your unit.

4-2. SPECIAL TOOLS, TMDE, AND SUPPORT EQUIPMENT.

Refer to the Maintenance Allocation Chart contained in Appendix B for maintenance tasks authorized at unit level maintenance and the TMDE and support equipment required to perform these tasks. No special tools are required to maintain the Tactical Water Distribution System.

4-3. REPAIR PARTS.

Repair parts are listed and illustrated in the repair parts and special tools list, TM 10-4320-345-24P, covering unit, direct support, and general support maintenance of this equipment.

Section II. SERVICE UPON RECEIPT

4-4. SITING

- a. Transport. The water system is designed to be packaged and shipped inside four TRICONS, 64 flaking boxes and various crating supplied with the system. Transport the water system only on equipment compatible with TRICON transport requirements (TM55-8145-200-13&P).
- b. Site Selection. When selecting a site for installation of the water system, consider the overall operating area. Siting must include access to the water source, adequate space to set up four 600 gpm pumping stations, two water storage and distribution points and associated hoseline to connect the water system to large water distribution centers (maximum hoseline length is 10 miles). Site should be level and provide good water drainage away from system components. If possible, site should slope down hill from water source to water dispensing points.

4-5. SHELTER REQUIREMENTS

The water system does not require special sheltering during normal operation. Heated shelters may be required when operating in extremely cold conditions (below 32°F). Store unused water system components in the TRICONS and packing crates to prevent damage and minimize routine maintenance.

4-6. CHECKING UNPACKED EQUIPMENT.

- a. General. The water system is packaged and shipped in four TRICONS and 64 flaking boxes. Component parts required to assemble the pump stations, storage and distribution points and connect the hoseline segments are stored in the TRICONS. The 600 gpm pumps, 125 gpm pumps, hypochlorination units, and 20K collapsible fabric tanks are separately packaged and crated. Where possible, save crating inside the TRICON for reuse to make repacking easier. When unpacking the equipment, keep in mind that the system is made up of different connection kits. This manual addresses installation and use of all connection kits, but you may not need all of these components to perform your mission. Your operating requirements will determine which connection kits/components are needed to perform the mission.
- b. Unpack 20K Collapsible Water Tanks Refer to Applicable TM to unpack the water tanks.
- c. Unpack 600 Gpm Pumps. Refer to applicable TM to unpack the 600 gpm pumps.
- d. Unpack 125 Gpm Pumps. Refer to applicable TM to unpack the 125 gpm pumps.
- e. Unpack Hypochlorination Units. Refer to applicable TM to-unpack the hypochlorination units.
- f. Checking Unpacked Equipment
 - (1) Inspect equipment stencils, markings and information plates. All items should be clear and readable
 - (2) Inspect the equipment for any damage incurred during shipment. If the equipment has been damaged, report the damage on SF 364, Report of Discrepancy
 - (3) Inspect components to make sure they are in serviceable condition.
 - (4) Check equipment against the packing slip to see if the shipment is complete. Report all discrepancies in accordance with the instructions of DA Pam 738-750.
 - (5) Check to see if the equipment has all applicable MWOs incorporated.
- g. Processing Unpacked Equipment
 - (1) Remove all tape, paper wrapping, plastic sheeting and packing materials from the water system components.
 - (2) Refer to the applicable TM for processing and servicing the 600 gpm pumps.
 - (3) Refer to the applicable TM for processing and servicing the 125 gpm pumps.
 - (4) Refer to the applicable TM for processing and servicing the hypochlorination units.
 - (5) Refer to the applicable TM for processing the 20K collapsible fabric tanks.

Section III. UNIT TROUBLESHOOTING PROCEDURES

4-7. INTRODUCTION.

This section provides the troubleshooting information for the Tactical Water Distribution System at the Unit Maintenance level. It consists of the symptom index, listing the most common malfunction symptoms, and the troubleshooting table, Table 4-1. This table repeats the malfunctions, and provides the procedural steps and corrective actions necessary to return the system to operational readiness.

4-8. TROUBLESHOOTING .

- a. The troubleshooting table lists the common malfunctions which you may find during operation of the water system. You should perform the tests, inspections and corrective actions in the order they appear in the table.
- b. This table cannot list all the malfunctions that may occur, all the tests or inspections needed to find the fault, or all the corrective actions needed to correct the fault. If the equipment malfunction is not listed or actions listed do not correct the fault, notify your supervisor.
- c. Refer to the applicable TM for troubleshooting malfunctions on the 350 gpm pumps.
- d. Refer to the applicable TM for troubleshooting malfunctions on the 125 gpm pump.
- e. Refer to the applicable TM for troubleshooting malfunctions on the hypochlorination units.
- f. Refer to the applicable TM for troubleshooting malfunctions on the 20K collapsible fabric tanks.

4-9. MALFUNCTION INDEX.

Malfunction	Page
1. Discharge or Suction Hose Leaks.....	4-5
2. Gate Valve Assembly (2-Inch) Leaks.....	4-6
3. Gate Valve (2-Inch) Stuck or Jammed.....	4-7
4. Distribution Nozzle (1-1/2 inch) Leaks.....	4-8
5. Distribution Nozzle (1-1/2 inch) Stuck Open or Closed.....	4-9
6. Water Meter Assembly Leaks.....	4-10
7. Water Meter Assembly Will Not Operate	4-11
8. Elbow Valve Leaks	4-12
9. Elbow Valve Stuck or Jammed	4-13
10. Butterfly Valve Leaks.....	4-14
11. Butterfly Valve Stuck Open or Closed.....	4-15
12. Pressure Regulating Valve Leaks.....	4-16
13. Pressure Regulating Valve Not Reducing Pressure.....	4-17
14. Gate Valve Assembly (4-inch) Leaks	4-18
15. Gate Valve Assembly (4-inch) Stuck Open or Closed.....	4-19

Table 4-1. Unit Troubleshooting.

MALFUNCTION 1. SUCTION OR DISCHARGE HOSE LEAKS.

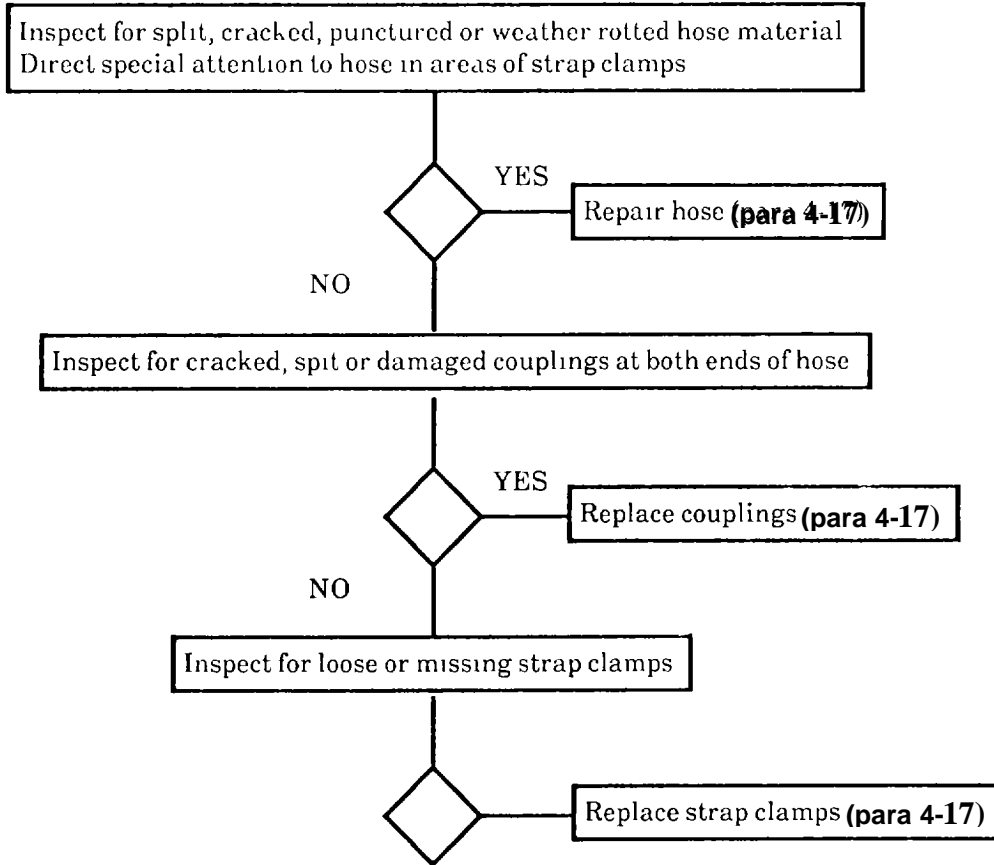

Table 4-1. Unit Troubleshooting - cont.

MALFUNCTION 2. GATE VALVE ASSEMBLY (2-INCH) LEAKS .

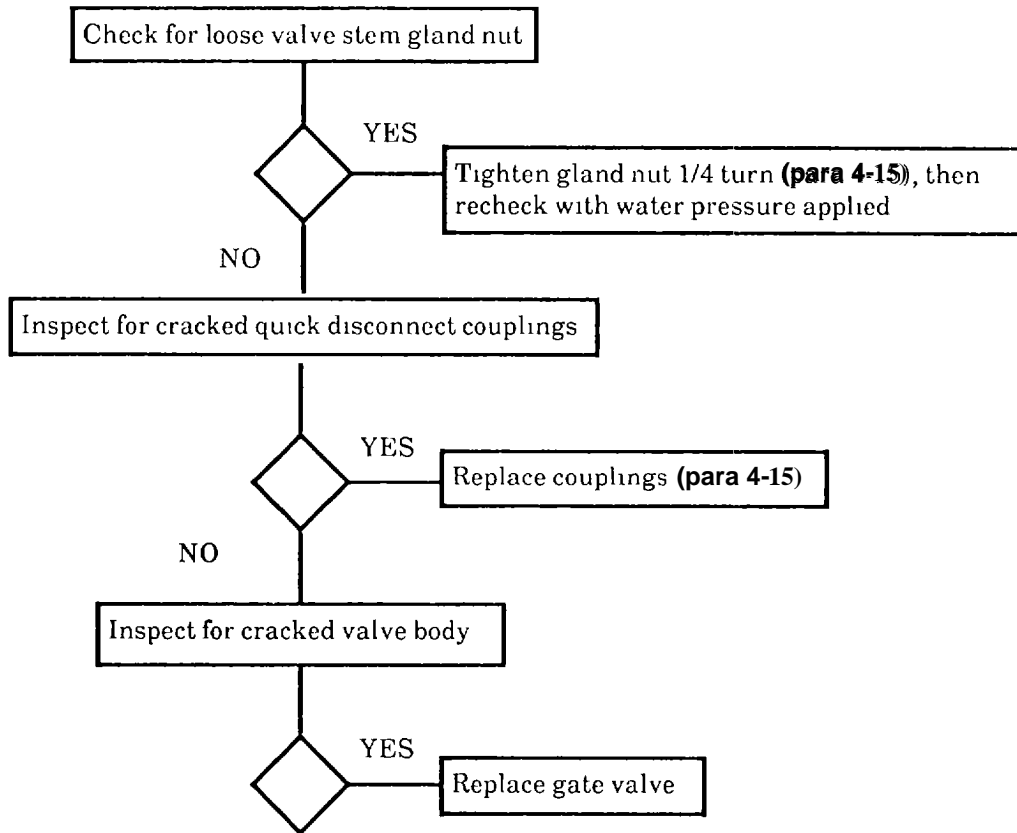

Table 4-1. Unit Troubleshooting - cont.

MALFUNCTION 3. GATE VALVE ASSEMBLY (2-INCH) STUCK OR JAMMED.

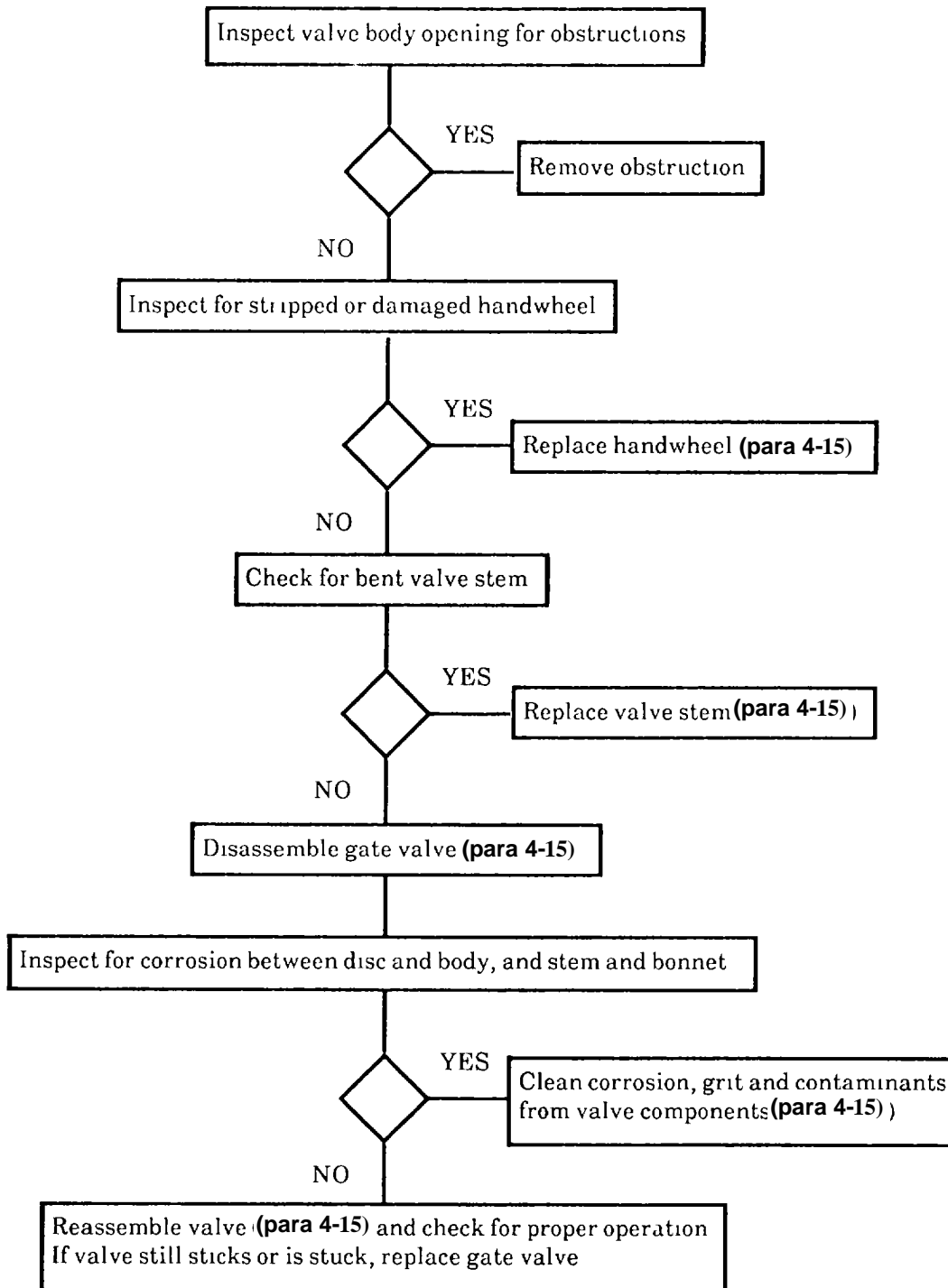

Table 4-1. Unit Troubleshooting - cont.

MALFUNCTION 4. DISTRIBUTION NOZZLE (1-1/2 INCH) LEAKS.

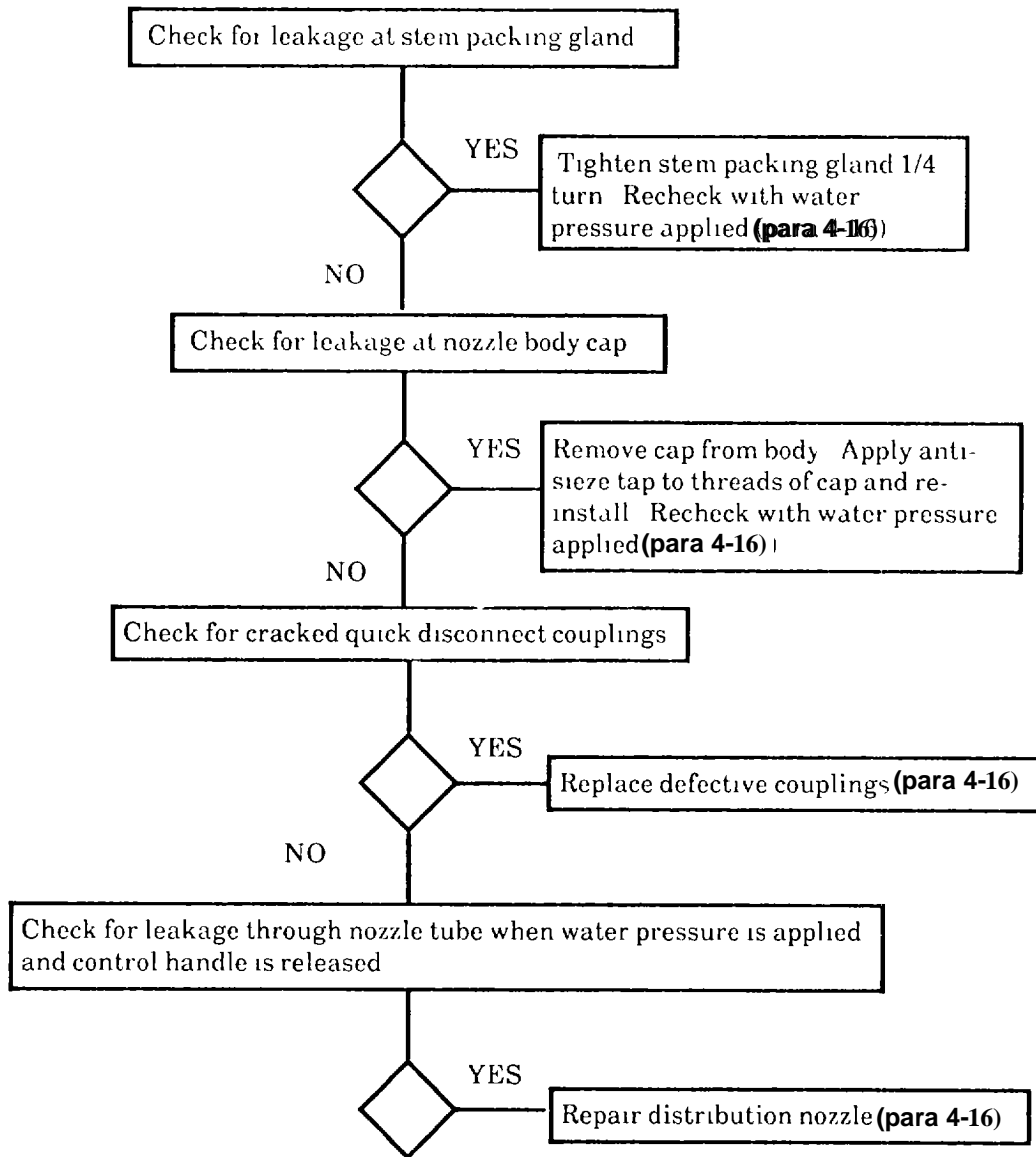

Table 4-1. Unit Troubleshooting - cont.

MALFUNCTION 5. DISTRIBUTION NOZZLE (1-1/2 INCH) STUCK OPEN OR CLOSED.

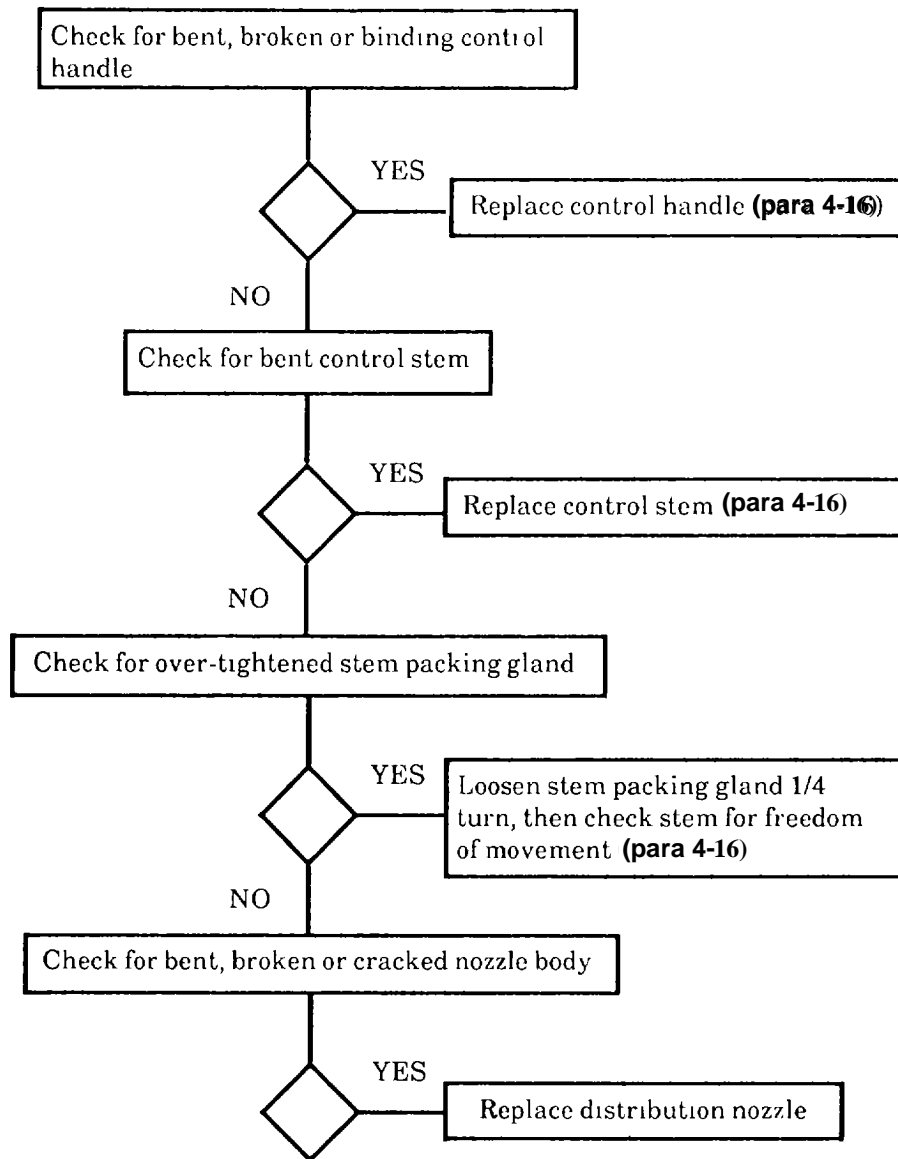

Table 4-1. Unit Troubleshooting - cont.

MALFUNCTION 6. WATER METER ASSEMBLY LEAKS .

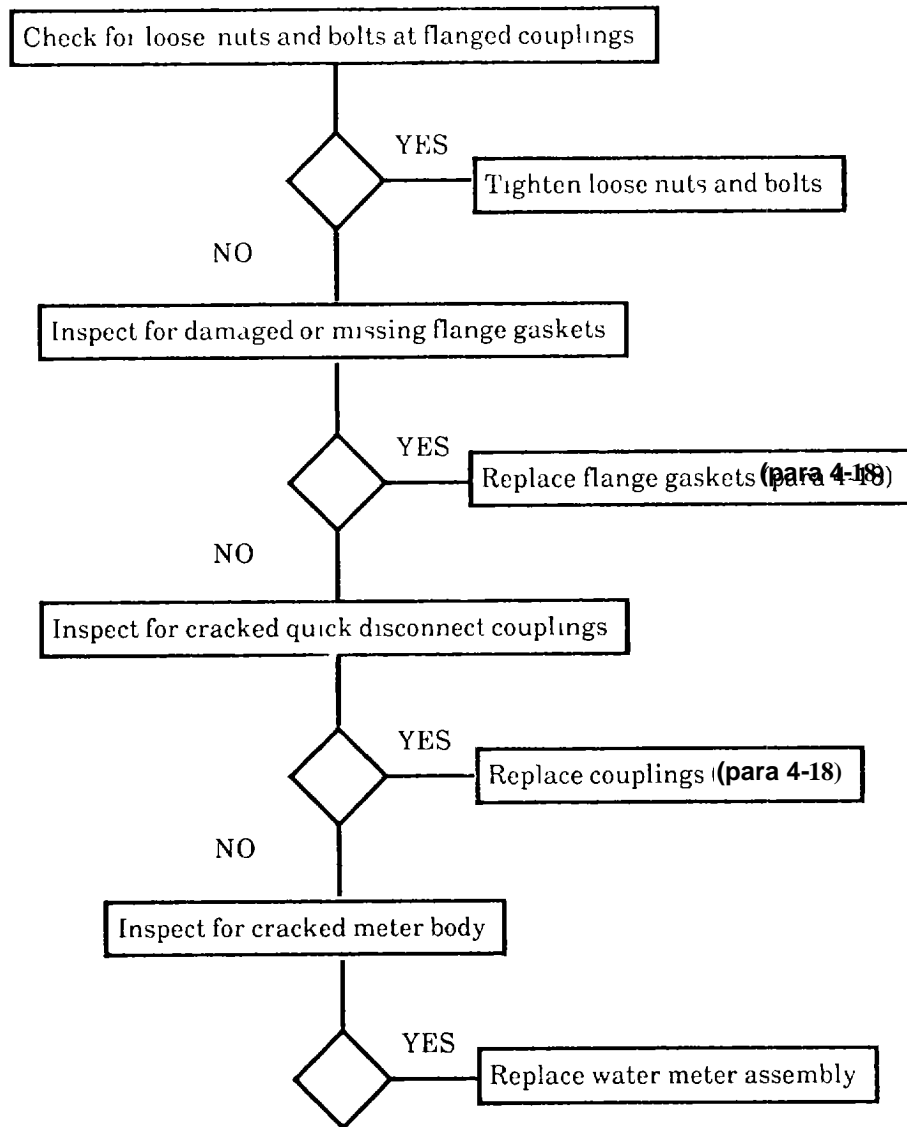

Table 4-1. Unit Troubleshooting- cont.

MALFUNCTION 7. WATER METER ASSEMBLY WILL NOT OPERATE.

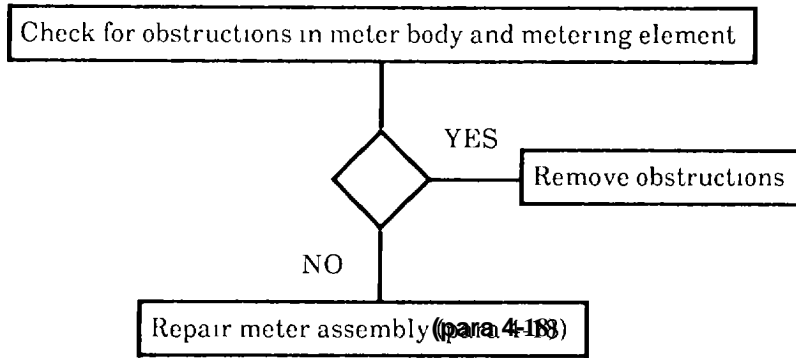

Table 4-1. Unit Troubleshooting - cont.

MALFUNCTION 8. ELBOW VALVE LEAKS.

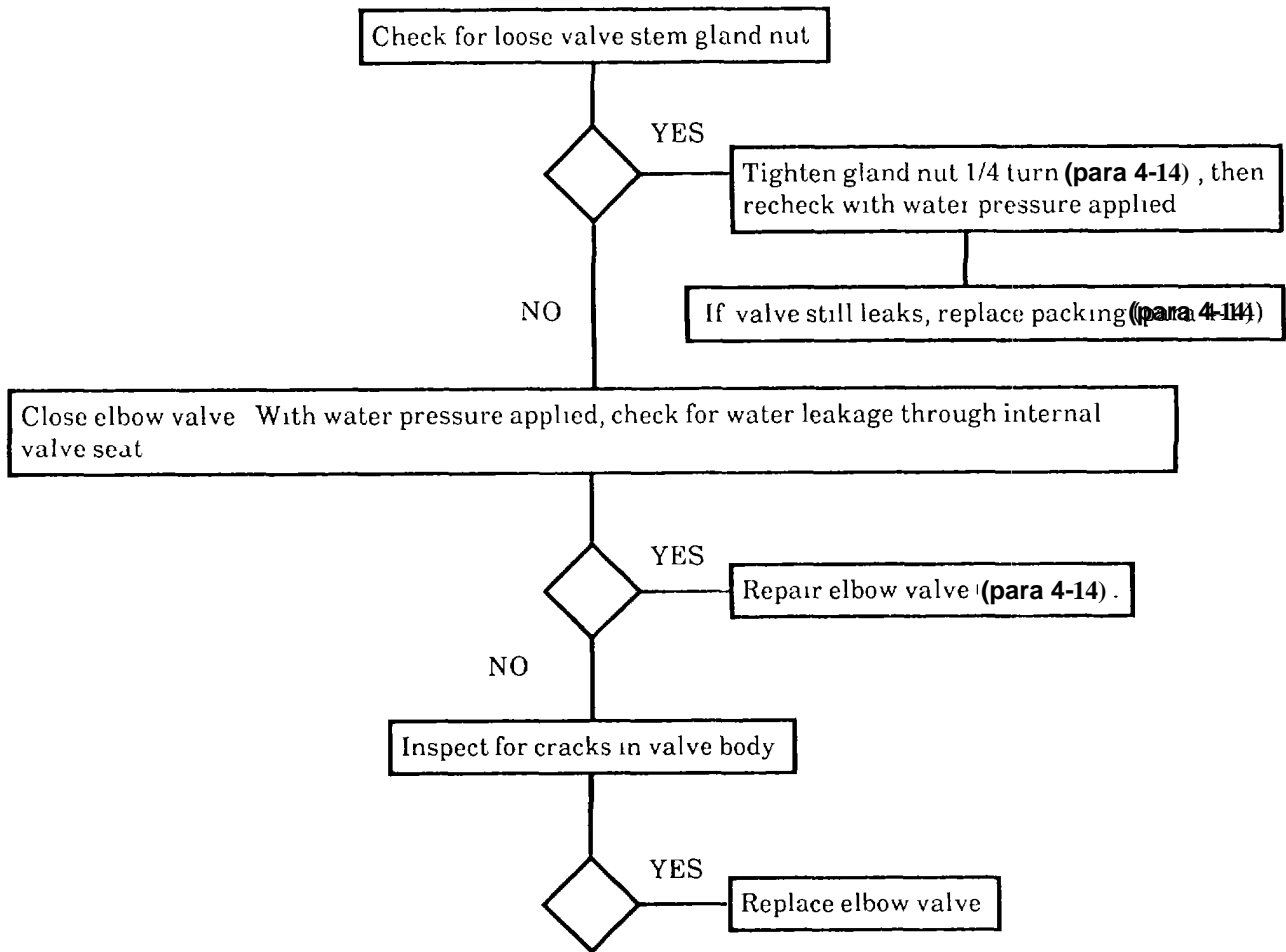

Table 4-1. Unit Troubleshooting - cont.

MALFUNCTION 9. ELBOW VALVE STUCK OR JAMMED.

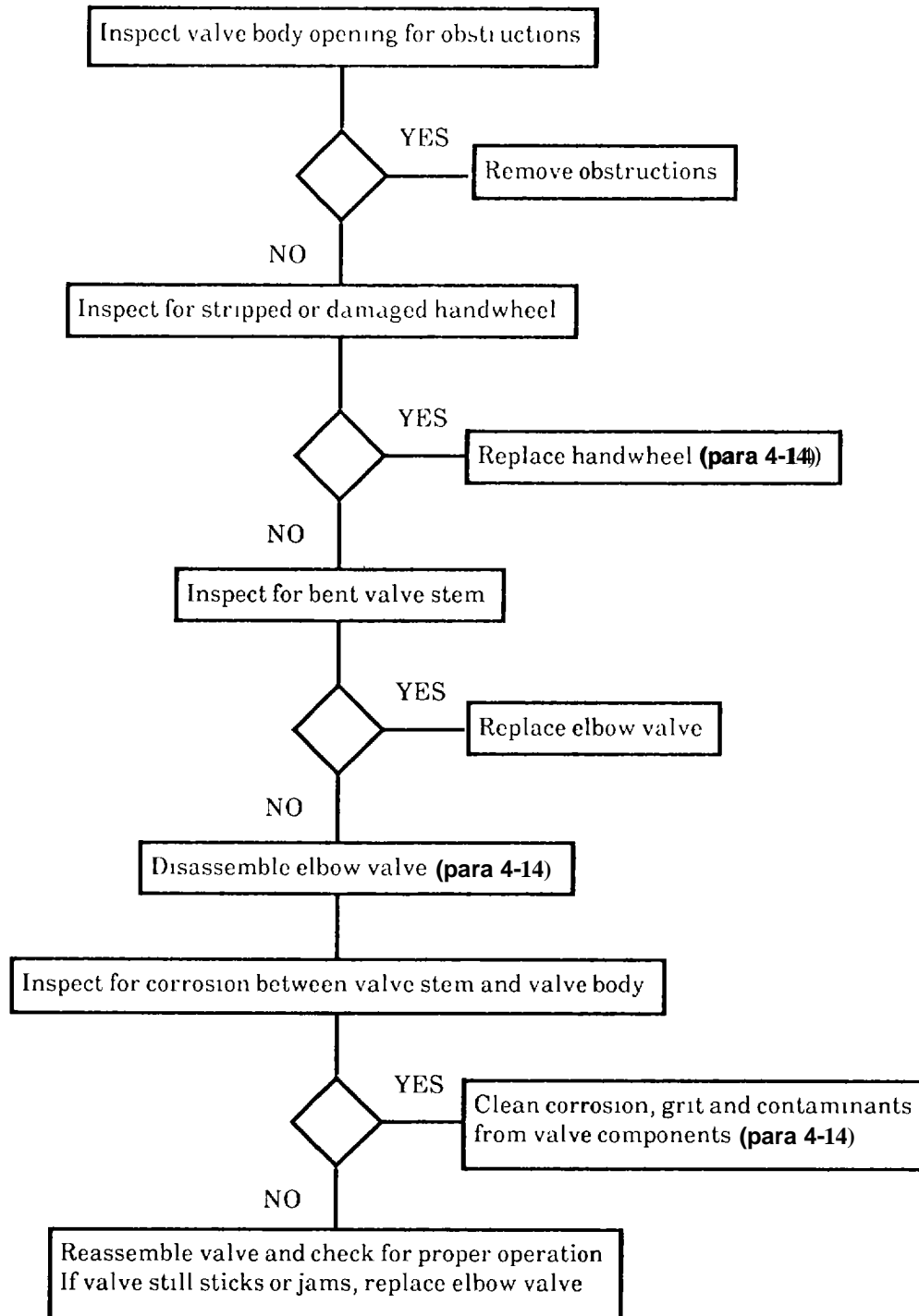

Table 4-1. Unit Troubleshooting - cont.

MALFUNCTION 10. BUTTERFLY VALVE ASSEMBLY LEAKS.

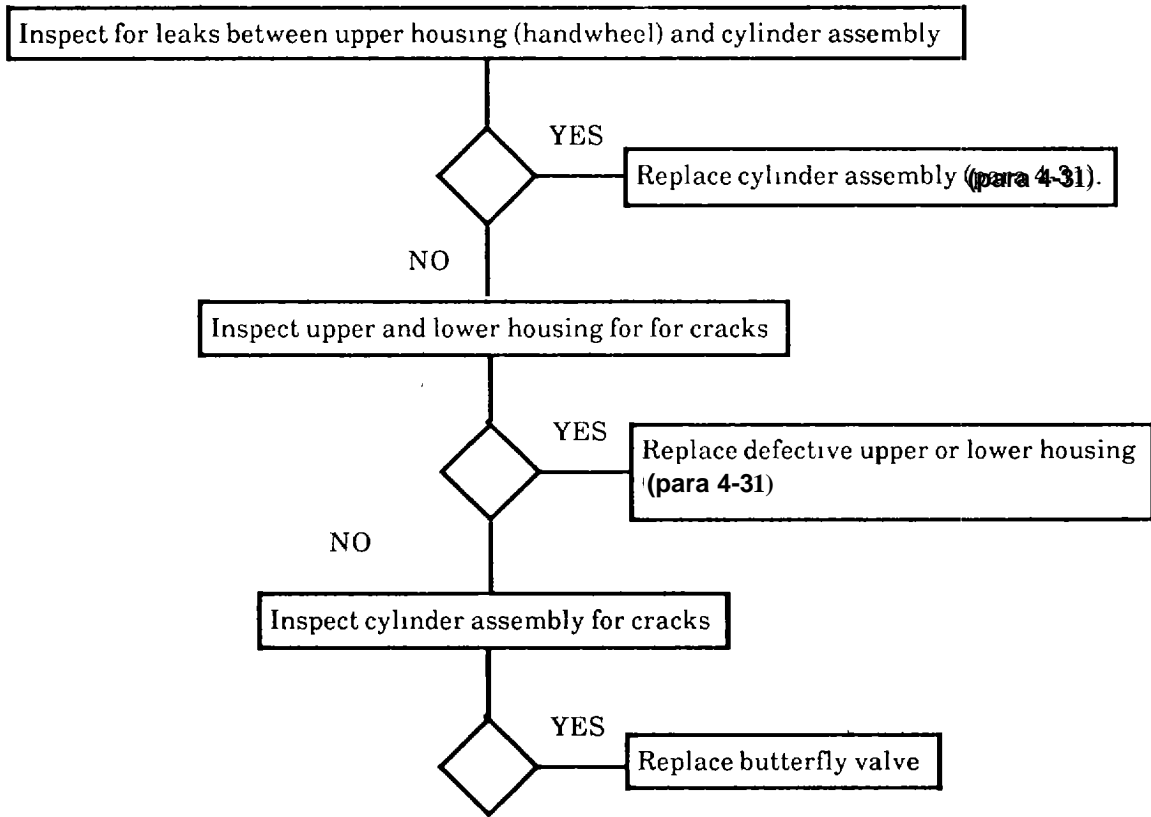

Table 4-1. Unit Troubleshooting - cont.

MALFUNCTION 11. BUTTERFLY VALVE ASSEMBLY STUCK OPEN OR CLOSED.

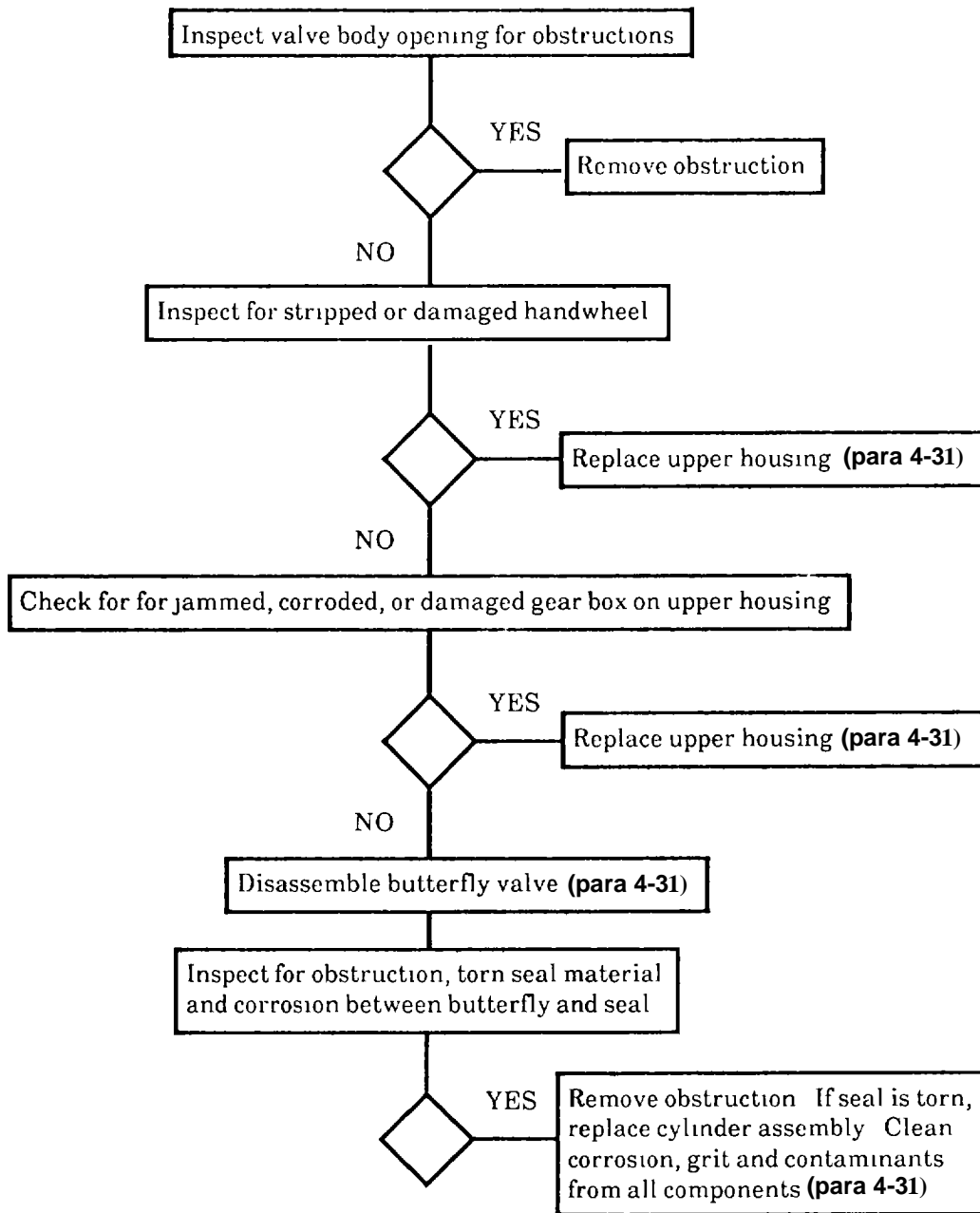

Table 4-1. Unit Troubleshooting - cont.

MALFUNCTION 12. PRESSURE REGULATING VALVE LEAKS.

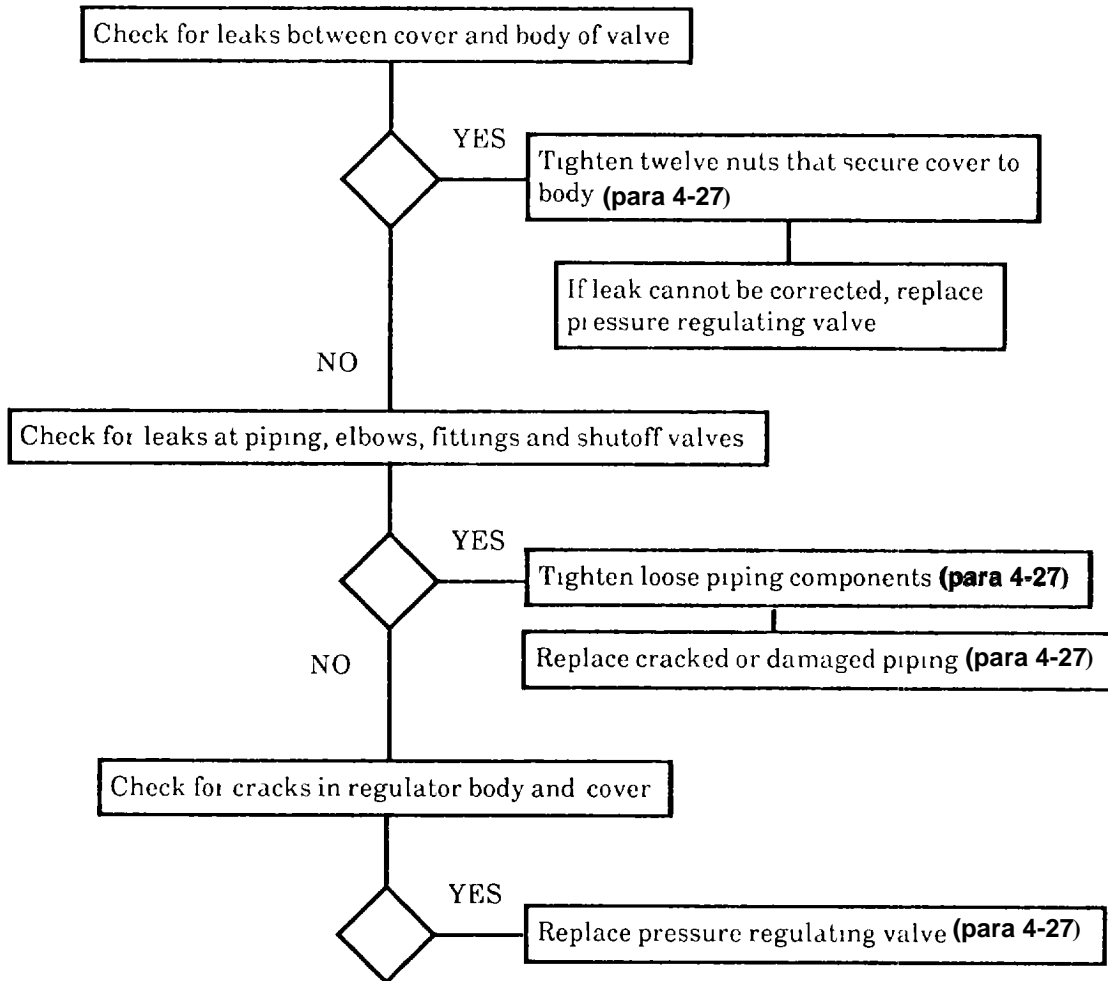

Table 4-1. Unit Troubleshooting - cont.

MALFUNCTION 13. PRESSURE REGULATING VALVE NOT REDUCING PRESSURE.

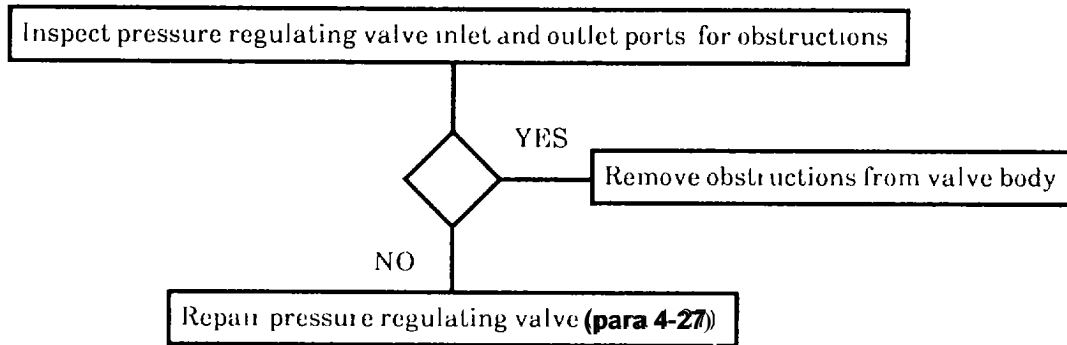

Table 4-1. Unit Troubleshooting - cont.

MALFUNCTION 14. GATE VALVE ASSEMBLY (4-INCH) LEAKS.

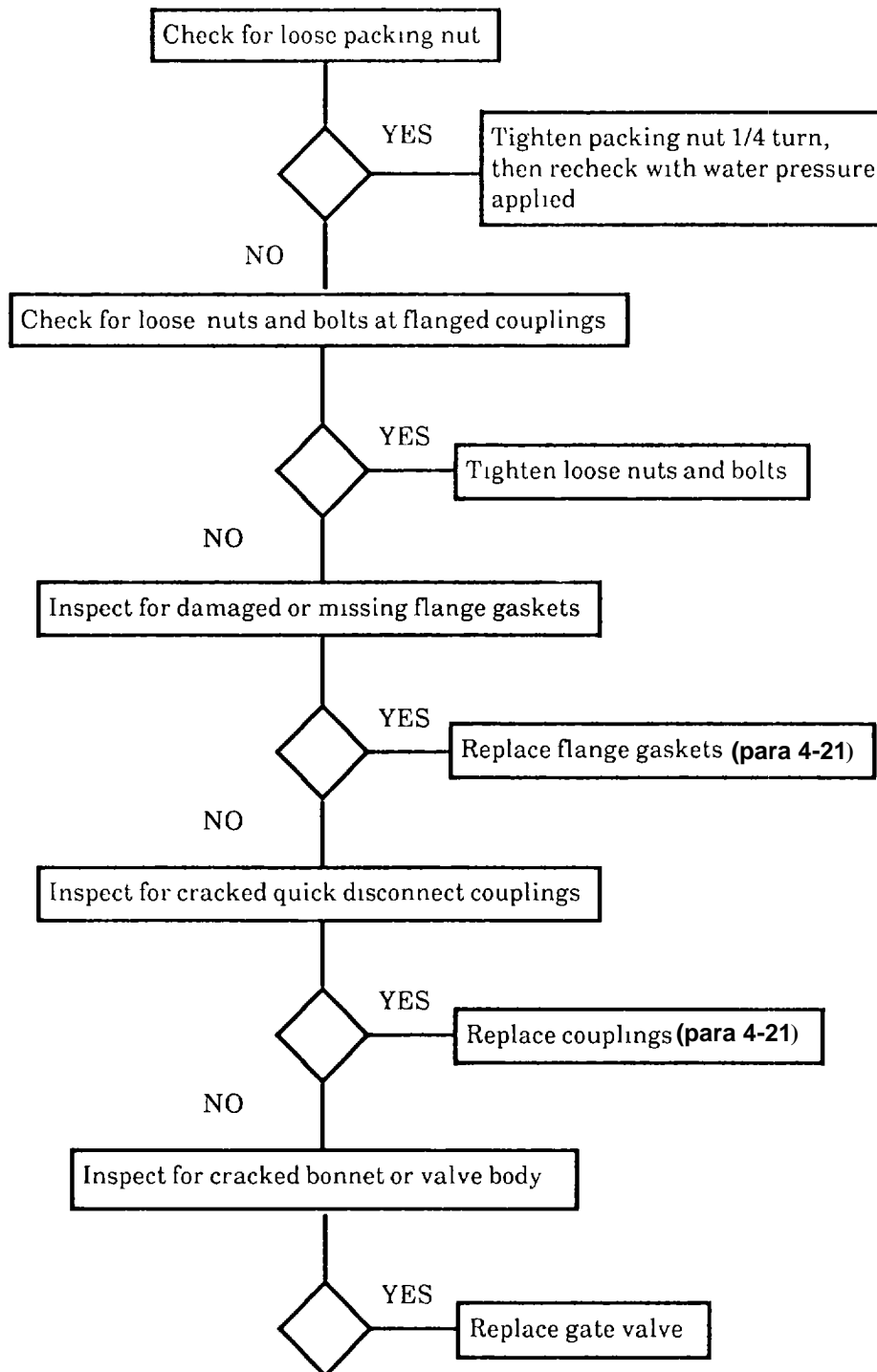
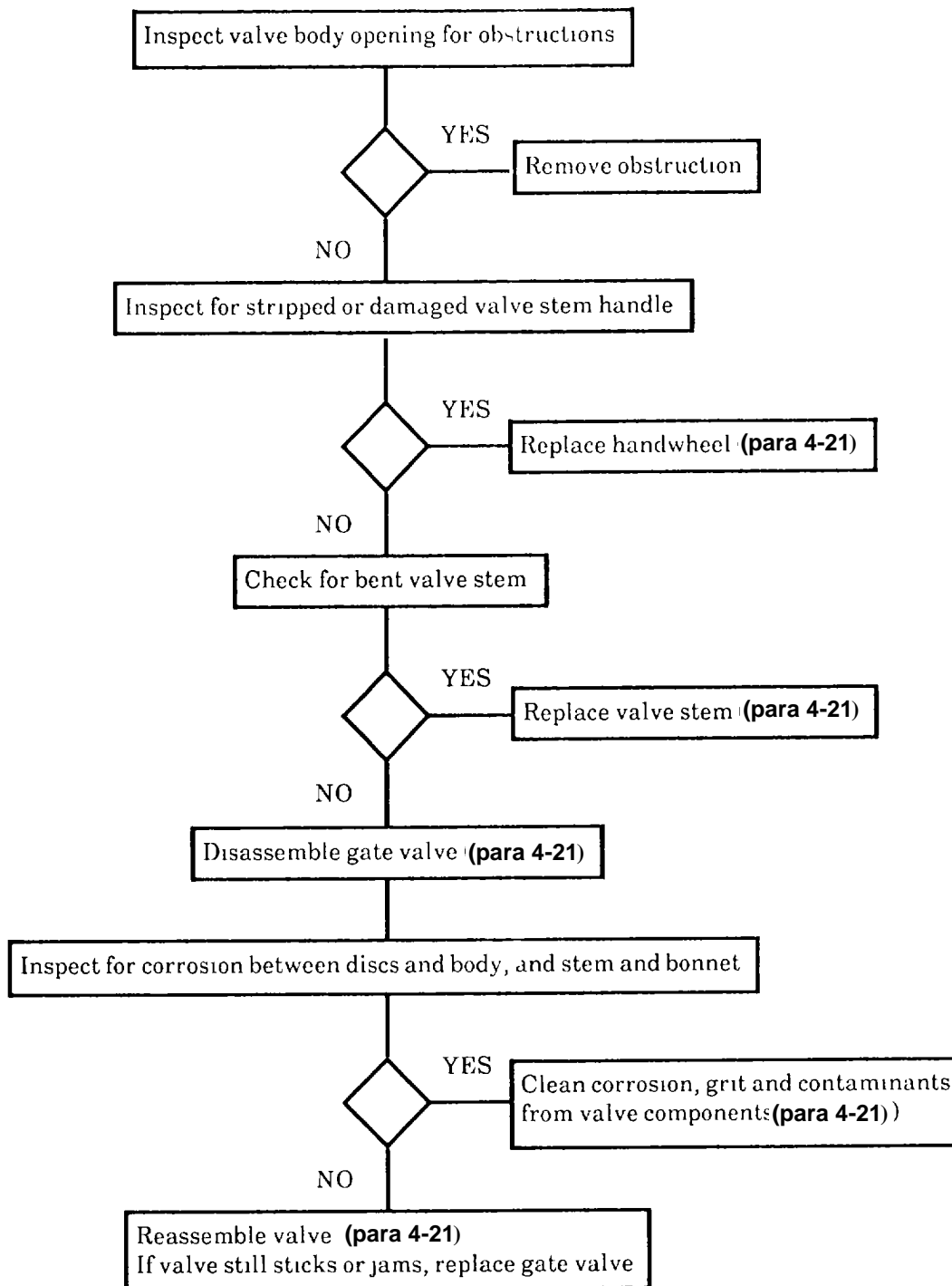

Table 4-1. Unit Troubleshooting - cont.

MALFUNCTION 15. GATE VALVE ASSEMBLY (4-INCH) STUCK OPEN OR CLOSED.



Section IV. UNIT MAINTENANCE PROCEDURES

4-10. GENERAL.

This section contains instructions for performing unit level maintenance on the Tactical Water Distribution System. Refer to applicable technical manuals for unit maintenance on the following equipment

Hypochlorination Unit.....	Applicable TM
125 Gpm Pump Assembly.....	Applicable TM
600 Gpm Pump Assembly.....	Applicable TM
20K Collapsible Fabric Tank.....	Applicable TM
TRICON.....	TM 55-8145-200-13&P

4-11. PERSONAL SAFETY.

To ensure safety of personnel, proper care should be used when handling assemblies and components. Many assemblies are heavy. The assistance of another person, lifting device, or other support equipment may be required to move or position heavy items.

Personnel must remove all items of jewelry (rings, bracelets, watches, necklaces etc) and loose clothing before working on the equipment. Jewelry and loose clothing can get caught in moving equipment and result in injury to personnel. Jewelry can cause electrical shorts or severe injury when working around electrical equipment.

When performing maintenance on the water system, keep in mind that the purpose of the equipment is to store and distribute potable water. Cleaning fluids, lubricants, preservatives, paint or other chemicals must not be allowed to contaminate the water system. Clean water system components with only approved materials.

Operate the water system after performing maintenance to ensure repairs have been performed correctly and system can be returned to service.

4-12. PROPER EQUIPMENT.

Obtain proper equipment before beginning maintenance. This includes hand tools and/or special tools, receptacles for storing small parts, and expendable materials required by the maintenance task.

4-13. DISTRIBUTION POINT MAINTENANCE.

The distribution point consists of the components listed below. Refer to the following paragraphs for applicable maintenance procedures.

Procedure	Para.
Elbow Valve Repair.....	4-14
Gate Valve Assembly (2-Inch)Repair.....	4-15
Distribution Nozzle (1-1/2 Inch) Repair.....	4-16
Suction and Discharge Hose Repair.....	4-17
Water Meter Assembly Repair.....	4-18
Nozzle Stand Assembly Repair.....	4-19

4-14. ELBOW VALVE REPAIR.

This task covers:

- | | | |
|-------------------------------------|------------------------------------|----------------------|
| <p>a. Disassembly
d. Repair</p> | <p>b. Cleaning
e. Assembly</p> | <p>c. Inspection</p> |
|-------------------------------------|------------------------------------|----------------------|
-

INITIAL SETUP:

Tools:

General Mechanics Tool Kit (Item 1, App B)
 Pipe Wrench (Item 2, App B)
 Vice (Item 2, App B)

Equipment Condition :

Elbow valve removed (para 3-4a)

Material/Parts:

Detergent, General Purpose (Item 1, App E)
 Wiping Rag (Item 2, App E)
 Coupling Gasket (2) (Item 1, App I)
 Packing (Item 9, App I)

NOTE

Ensure that all parts identified as mandatory replacement parts are discarded and replaced with new components.

- a. Disassembly. Refer to figure 4-1.
- (1) Remove nut (1), washer (2) and handwheel (3) from stem (9)
 - (2) Unscrew packing nut (4) from valve body (10)

CAUTION

Use care when removing packing to prevent scratching stem. Scratching stem will cause premature failure of elbow valve.

- (3) Remove packing gland (5) and packing (6) from stem (9)
 - (4) Remove coupling gaskets (7 and 8) from valve body (10).
- b. Cleaning.
- (1) Wash all components with clean water and detergent
 - (2) Rinse components in clean water and dry with wiping rag
- c. Inspection.
- (1) Inspect valve body (10) for cracks and corrosion.
 - (2) Inspect sealing surface of stem (9) for scoring, scratches and nicks
- d. Repair. Replace damaged parts and all sealing components. If stem (9) or valve body (10) is damaged or defective, replace entire elbow valve

4-14. ELBOW VALVE REPAIR - cont.

e. Assembly. Refer to figure 4-1.

- (1) Install coupling gaskets (7 and 8) in valve body (10)
- (2) Install packing (6) and packing gland (5) on stem (9)
- (3) Screw packing nut (4) onto valve body (10)
- (4) Place handwheel (3) on stem (9) and install washer (2) and nut (1)
- (5) Install elbow valve in water system (para 3-4).
- (6) Startup water system (para 2-13c) and check elbow valve assembly for leaks. If valve leaks at stem (9), tighten packing nut (4) 1/4 turn until leak stops. Do not over tighten.

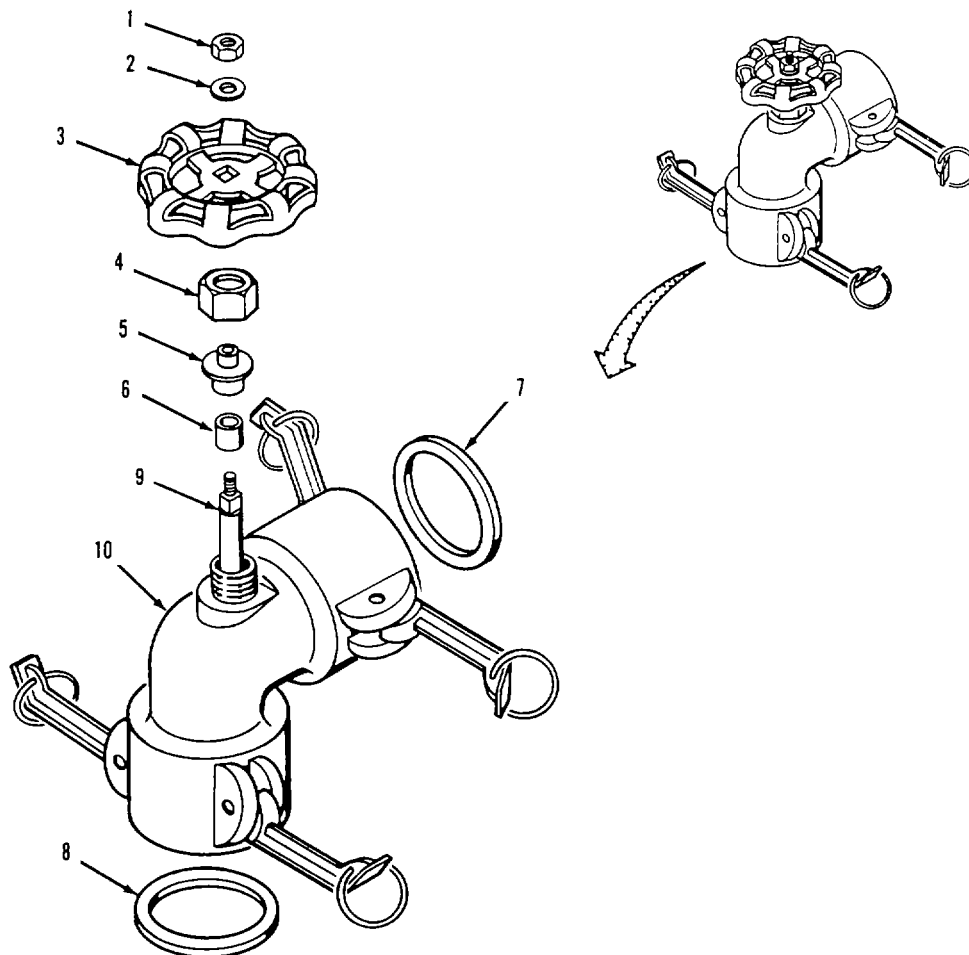

Figure 4-1. Elbow Valve Repair.

4-15. GATE VALVE ASSEMBLY(2-INCH) REPAIR.

This task consists of: a. **Disassembly** b. **Cleaning** c. **Inspection**
 d. **Repair** e. **Assembly**

INITIAL SET-UP:	
<p>Tools: General Mechanics Tool Kit (Item 1, App B) Pipe Wrench (Item 2, App B) Vice (Item 2, App B)</p> <p>Equipment Condition : Gate valve assembly removed (para 3-4a)</p>	<p>Material/Parts: Detergent, General Purpose (Item 1, App E) Wiping Rag (Item 2, App E) Tape, Anti-seize (Item 4, Appendix E) Coupling Gasket (Item 1, App I) Packing (Item 7, App I)</p>

NOTE

Ensure that all parts identified as mandatory replacement parts are discarded and replaced with new components

- a. Disassembly. Refer to figure 4-2.
- (1) Clamp gate valve body (13) in vise.
 - (2) Remove gasket (1) from female coupling (2).
 - (3) Using pipe wrench, unscrew female coupling (2) from valve body (13).
 - (4) Using pipe wrench, unscrew male coupling (3) from valve body (13).
 - (5) Turn handwheel (5) fully clockwise to close valve.
 - (6) Remove handwheel nut (4) and handwheel (5) from stem (11).
 - (7) Using pipe wrench, remove bonnet ring (9) from valve body (13) Lift bonnet (10) and attached parts from valve body.
 - (8) Slide disc (12) from end of stem (11).
 - (9) Unscrew packing nut (6) from bonnet (10).
 - (10) Remove packing gland (7) and packing (8) from bonnet (10).
 - (11) Unscrew stem (11) from bottom of bonnet (10).
- b. Cleaning.
- (1) Wash all components with clean water and detergent.
 - (2) Rinse components in clean water and dry with wiping rag.

4-15. GATE VALVE ASSEMBLY(2-INCH) REPAIR - cont.

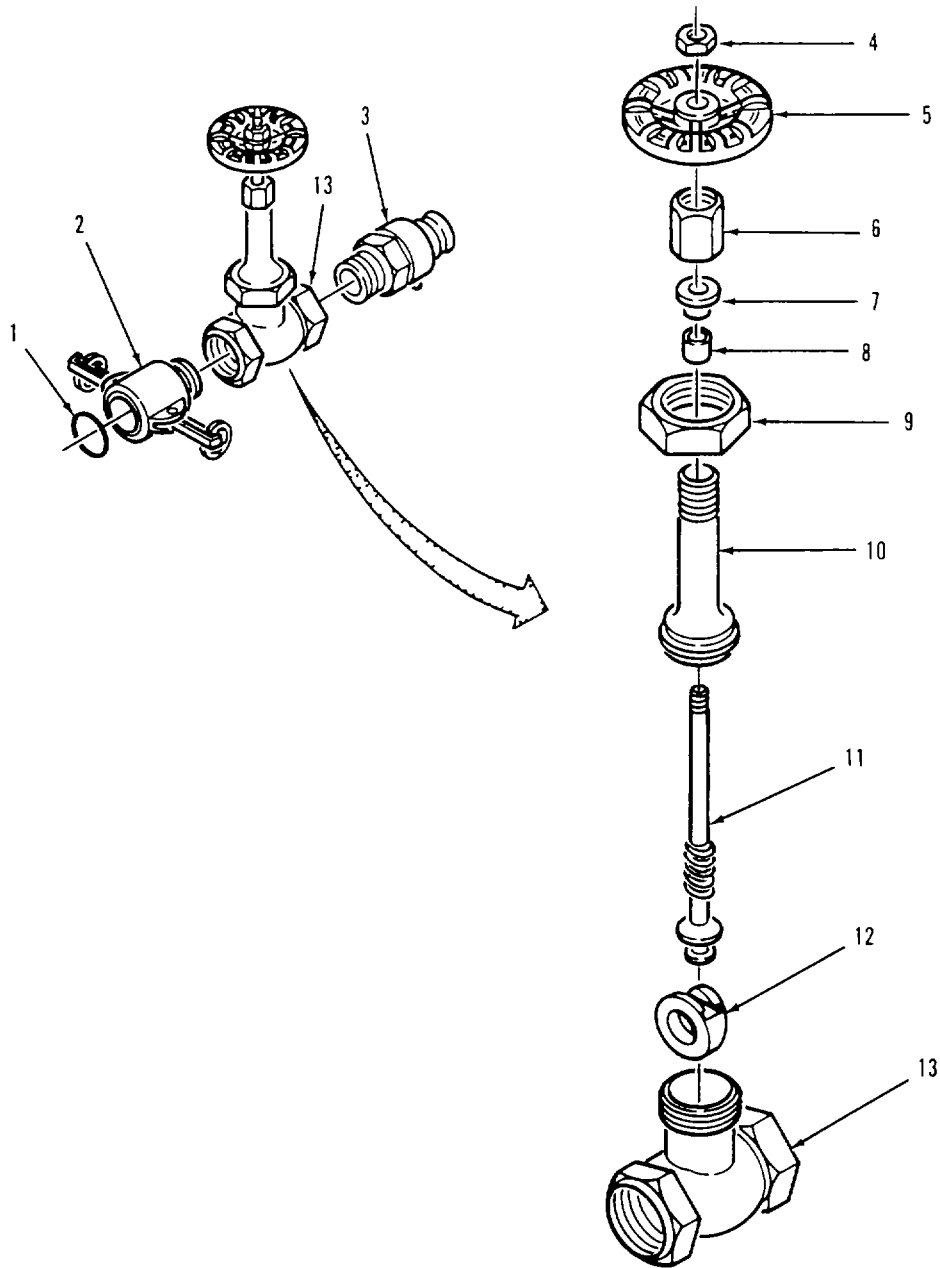

Figure 4-2. Gate Valve Assembly (2-inch) Disassembly.

4-15. GATE VALVE ASSEMBLY(2-INCH) REPAIR - cont.c. Inspection.

- (1) Inspect valve body (13) for cracks and stripped or damaged threads.
- (2) Inspect disc (12) for cuts or scratches across sealing surfaces.
- (3) Inspect bonnet (10) for cracks and stripped threads.
- (4) Inspect stem (11) for stripped, galled or damaged threads.
- (5) Inspect female coupling (2) for cracks, broken lock arms and damaged threads.
- (6) Inspect male coupling (3) for cracks and damaged threads.

d. Repair. Replace all defective parts. Do not reuse packing (8) or gasket (1) If disc (12) or valve body (13) is damaged, replace entire valve.e. Assembly. Refer to figure 4-3.

- (1) Screw stem (11) into bottom of bonnet (10).
- (2) Install new packing (8) and packing gland (7) over stem (11) and into bonnet (10)
- (3) Screw packing nut (6) onto bonnet (10)only finger tight.
- (4) Slide disc (12) onto end of stem (11).
- (5) Lower bonnet (10) and attached parts onto valve body (13) Make sure disc (12) fits in valve body seat.
- (6) Install bonnet ring (9) on valve body (13). Tighten packing nut (6).
- (7) Install handwheel (5) and handwheel nut (4) on stem (11).

NOTE

Ensure gasket is fully seated in groove of coupling.

- (8) Install gasket (1) in female coupling (2).

NOTE

Ensure that anti-seize tape is applied in the same direction as the threads.

- (9) Apply anti-seize tape to threads of female coupler (2). Using pipe wrench, screw coupler into valve body (13).
- (10) Apply anti-seize tape to threads of male coupler (3). Using pipe wrench, screw coupler (3) into valve body (13).
- (11) Install gate valve assembly in water system (para 3-4).

4-15. GATE VALVE ASSEMBLY(2-INCH) REPAIR - cont.

- (12) Install gate valve assembly (para 3-4b).
- (13) Startup water system (para 2-13c) and check valve assembly for leaks. If valve leaks at stem (11), tighten packing nut (6) 1/4 turn until leak stops. Do not over tighten.

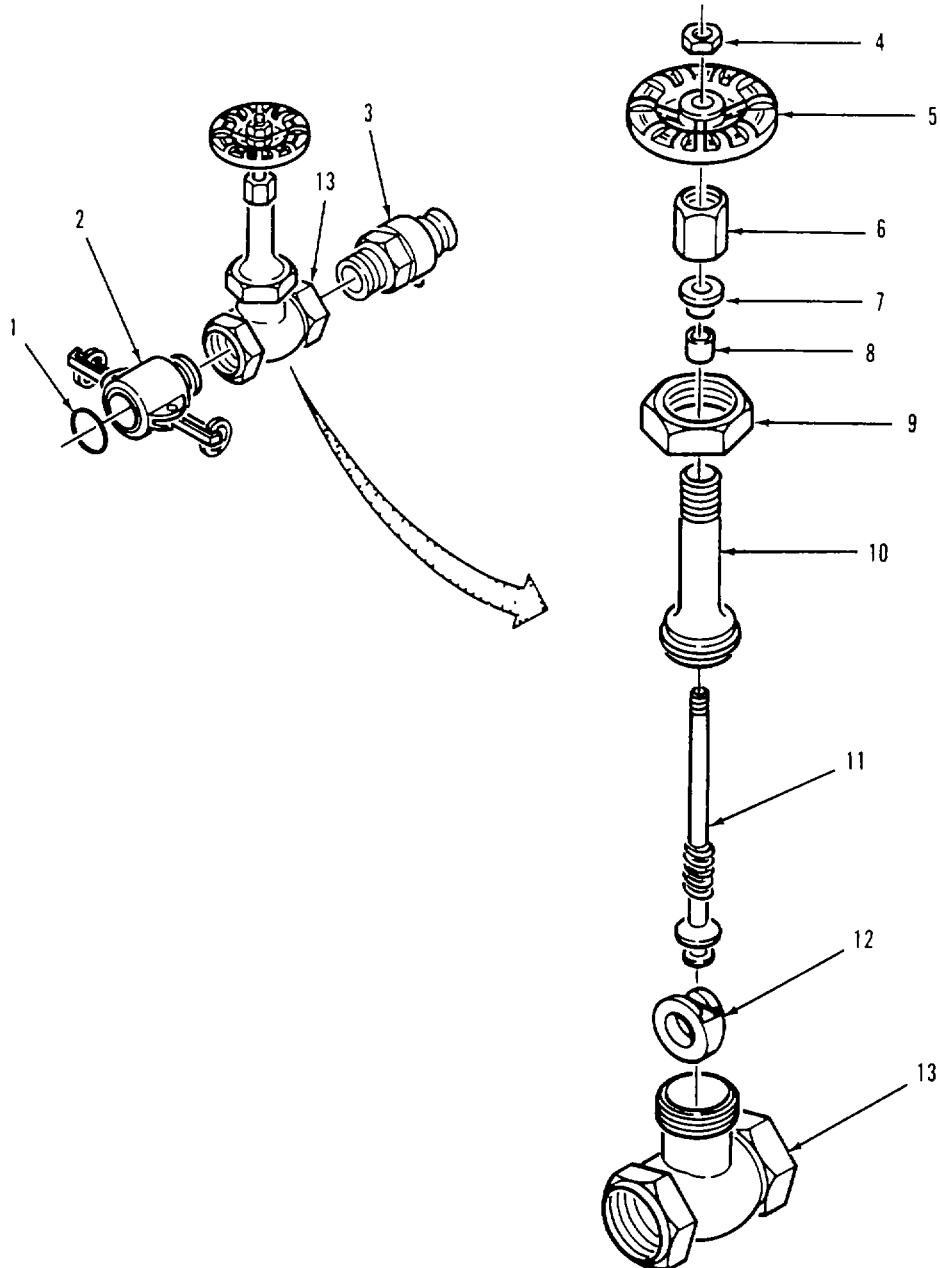

Figure 4-3. Gate Valve Assembly (2-inch) Assembly

4-16. DISTRIBUTION NOZZLE (1 1/2-INCH) REPAIR.

This task consists of **a. Disassembly** **b. Cleaning** **c. Inspection**
 d. Repair **e. Assembly**

INITIAL SET-UP:

Tools:

General Mechanics Tool Kit (Item 1, App B)
 Vice (Item 2, App B)

Equipment Condition :

Distribution nozzle removed (para 3-4a)

Material/Parts:

Detergent, General Purpose (Item 1, App E)
 Wiping Rag (Item 2, App E)
 Tape, Anti-seize (Item 4, Appendix E)
 Gasket (Item 2, App I)
 Packing (Item 8, App I)
 Disc (Item 9, App I)
 Disc (Item 10, App I)

NOTE

Ensure that all parts identified as mandatory replacement parts are discarded and replaced with new components.

a. Disassembly. Refer to figure 4-4.

- (1) Disconnect S-hook (1) from body (26).
- (2) Remove S-hook (1) from chain and spring (2).
- (3) Remove tube cap (4) and S-hook (3) from chain and spring (2) Disconnect S-hook from tube cap.
- (4) Remove gasket (5) from female coupling (6).
- (5) Remove swivel (7) and female coupling (6) from body (26).
- (6) Unscrew female coupling (6) from swivel (7).
- (7) Drive out groove pin (8) and remove handle (9) from body (26).

WARNING

To prevent injury to personnel, remove cap slowly Spring may be under tension.

- (8) Remove cap (10), gasket (11), spring (12) from body (26).
- (9) Remove assembled components (13, 14 and 15) from body (26).
- (10) Unscrew disc guide (15) from disc holder (13) and remove small disc (14).
- (11) Lift assembled components (16 through 19) from body (26).
- (12) Unscrew disc nut (16) from holder (17), then remove washer (18) and disc (19) from holder.

4-16. DISTRIBUTION NOZZLE (1 1/2-INCH) REPAIR.

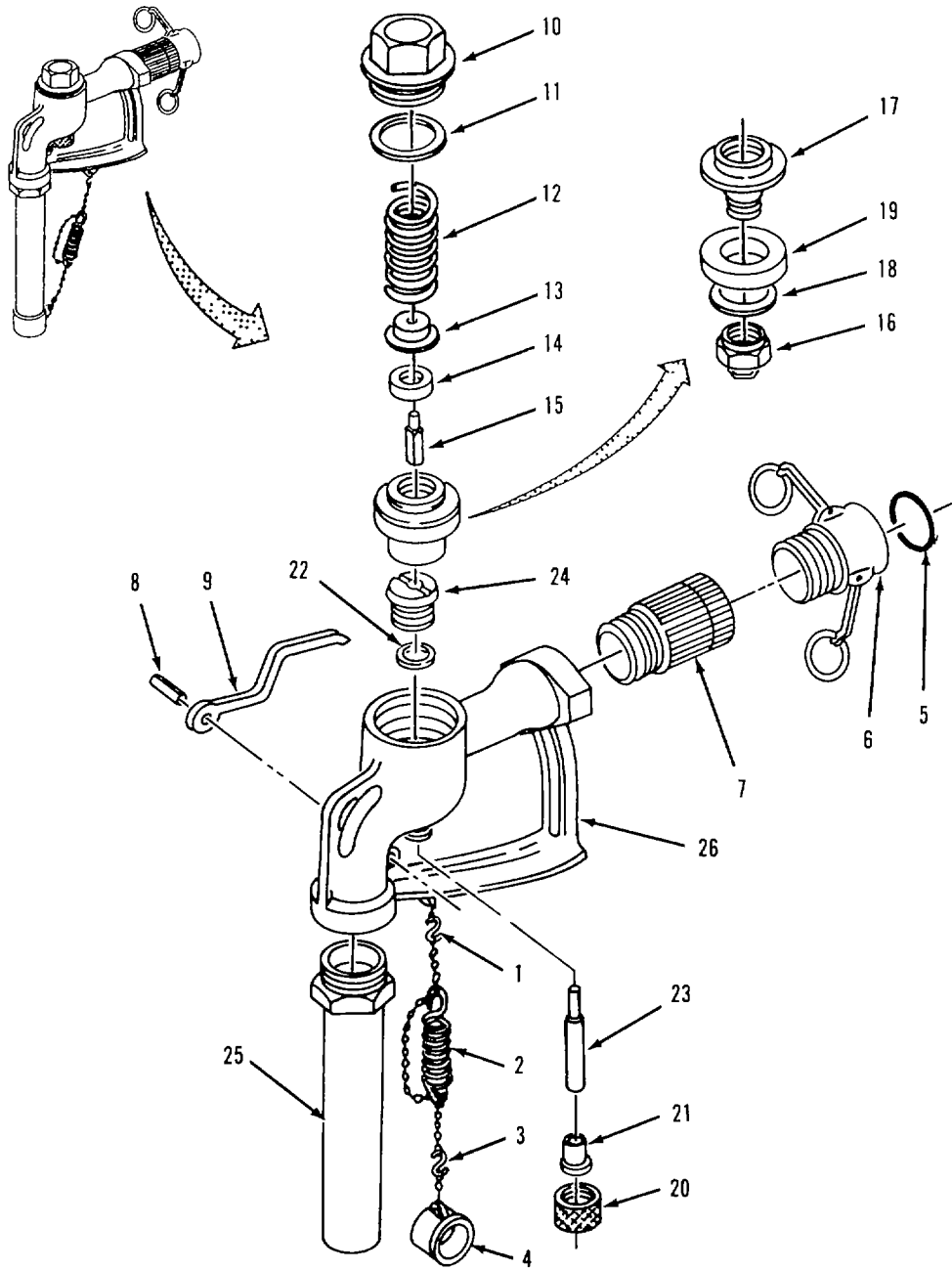

Figure 4-4. Distribution Nozzle (1-1/2 Inch) Disassembly.

4-16. DISTRIBUTION NOZZLE(I 1/2-INCH) REPAIR.

- (13) Loosen packing nut (20) and pull stem (23) from body (26).
- (14) Remove packing nut (20) and packing gland (21) from body (26).
- (15) Remove stuffing box (24) from body (26).
- (16) Remove packing (22) from bottom of stuffing box (24).
- (17) Unscrew tube and adapter (25) from body (26)

b Cleaning.

- (1) Wash all components with clean water and detergent.
- (2) Rinse components in clean water and dry with wiping rag.

c Inspection.

- (1) Inspect body (26) for cracks and stripped or damaged threads.
- (2) Inspect handle (9) for cracks.
- (3) Inspect tube and adapter (25) for bends, cracks, and deformation.
- (4) Inspect stem (23) for scoring Check that stem is straight.

d. Repair. Replace damaged parts and all sealing components.**e. Assembly. Refer to figure 4-5.**

- (1) Screw tube and adapter (25) into body (26).
- (2) Install packing (22) in stuffing box (24), then screw stuffing box down into body (26).
- (3) Push stem (23) in through body (26) and into stuffing box (24).
- (4) Place packing gland (21) and packing nut (20) over stem (23). Tighten packing gland onto body (26)
- (5) Position disc (19) and washer (18) on holder (17). Screw disc nut (16) into holder (17).
- (6) Position assembled components (16 through 19) in body (26).
- (7) Position small disc (14) on disc holder (13) Screw disc guide (15) into disc holder.
- (8) Position assembled components (13, 14 and 15) in body (26).

4-16. DISTRIBUTION NOZZLE (1 1/2-INCHI) IREPAIR - cont.

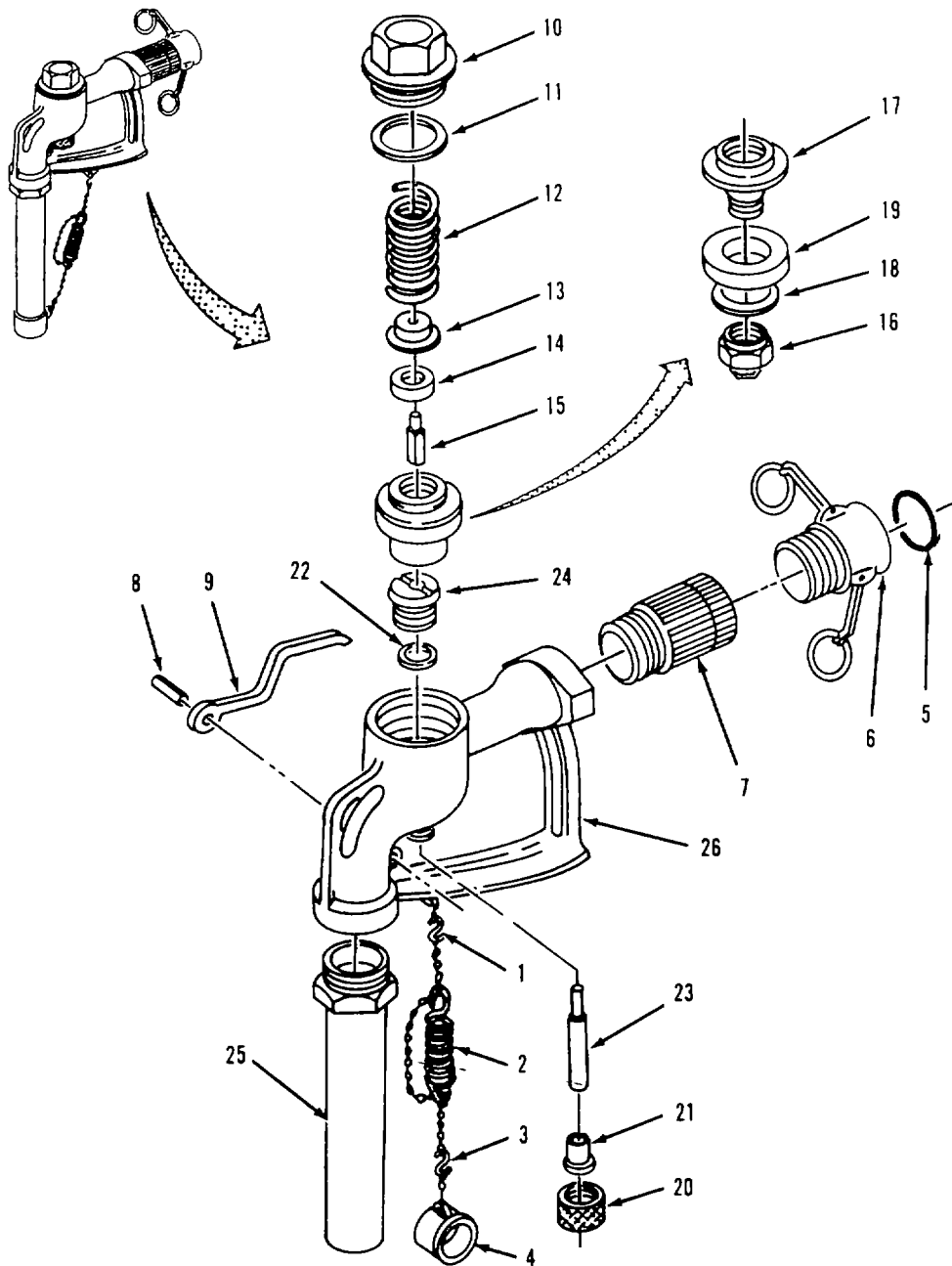

Figure 4-5. Distribution Nozzle (1 1/2-inch) Assembly.

4-16. DISTRIBUTION NOZZLE (1 1/2-INCH) REPAIR - cont.**NOTE**

Ensure that anti-seize tape is applied in the same direction as the threads

- (9) Apply anti-seize tape to threads of cap (10).
- (10) Install gasket (11) on cap (10).
- (11) Position spring (12) on top of disc holder (13).
- (12) Install cap (10) over spring (12) and onto body (26).
- (13) Position handle (9) on body (26) and install groove pin (8).
- (14) Apply anti-seize tape to male threads of swivel (7) and female coupling (6).
- (15) Screw female coupling (6) into swivel (7).
- (16) Screw swivel (7) and attached female coupling (6) onto body (26).
- (17) Install gasket (5) in female coupling (6).
- (18) Connect tube cap (4) to chain and spring (2) with S-hook (3).
- (19) Connect chain and spring (2) to body (26) with S-hook (1).
- (20) Install distribution nozzle in water system (para 3-4b).
- (21) Startup water system (para 2-13c) and check distribution nozzle for leaks.

4-17. DISCHARGE AND SUCTION HOSE REPAIR.

This task consists of **a. Disassembly** **b. Cleaning** **c. Inspection**
 d. Repair **e. Assembly**

INITIAL SET-UP:

<p>Tools: General Mechanics Tool Kit (Item 1, App B) Clamping Tool (Item 4, App B) Vice (Item 2, App B)</p> <p>Equipment Condition: Hose assembly removed (para 3-4a, 3-6a)</p> <p>Material/Parts: Detergent, General Purpose (Item 1, App E) Wiping Rag (Item 2, App E)</p>	<p>Determine additional materials required by hose size.</p> <p>Hose Size</p> <p>2-in Gasket (2) (Item 1, App I) Seal (4) (Item 11, App I) Strapping (A/R) (Item 12, App I)</p> <p>4-in Gasket (2) (Item 2, App I) Seal (4) (Item 11, App I) Strapping (A/R) (Item 12, App I)</p> <p>6 in Gasket (2) (Item 1, App I) Seal (8) (Item 13, App I) Strapping (A/R) (Item 14, App I)</p>
---	---

NOTES

- The following procedure applies to discharge and suction hoses. Quick disconnect couplings are shown, grooved couplings are similar.
- Ensure that all parts identified as mandatory replacement parts are discarded and replaced with new components. Disassemble hoses only to the level required to make repairs.
- 6-inch hoses required 4 straps at each coupling end.

a. Disassembly. Refer to figure 4-6.

- (1) Disconnect split ring (1) from female coupling (2) and remove dust plug (3).
- (2) Disconnect split ring (4) from male coupling (5) and remove dust cap (6).
- (3) Remove gasket (7) from dust cap (6).
- (4) Remove gasket (8) from female coupling (2).
- (5) Cut strapping (clamps) (9 and 10) from hose (11). Pull female coupling (2) from hose.
- (6) Cut strapping (clamps) (12 and 13) from hose (11). Pull male coupling (5) from hose.

b. Cleaning.

- (1) Wash all components with clean water and detergent.
- (2) Rinse components in clean water and dry with wiping rag.

4-17. DISCHARGE AND SUCTION HOSE REPAIR - cont

c. Inspection Refer to figure 4-6.

- (1) Inspect female coupling (2) and dust cap (6) for cracks, corrosion, and damaged locking arms.
- (2) Inspect male coupling (5) and dust plug (3) for cracks and corrosion
- (3) Inspect hose (11) for cuts, tears, punctures and delamination.

d. Repair. Replace damaged components. Do not reuse coupling gaskets (7 and 8) or strapping (9, 10, 12 and 13).

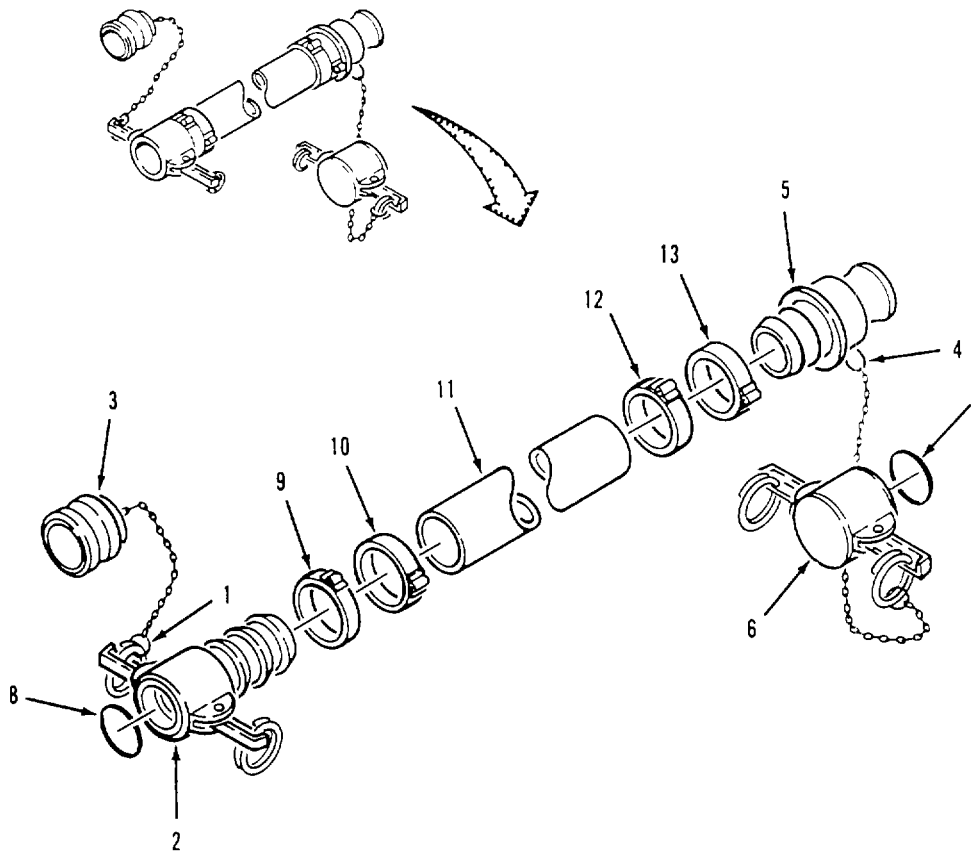

Figure 4-6. Discharge and Suction Hose Disassembly.

4-17. DISCHARGE AND SUCTION HOSE REPAIR - conte. Assembly

- (1) Push male coupling (5, figure 4-6) and female coupling (2) into hose (11).

NOTE

Strapping and seals are supplied in the accessory kit.

- (2) Cut a piece of strapping (1, figure 4-7) 36 inches long.
- (3) Slide seal (2) onto strapping (1) as shown. Bend end of strapping under seal.
- (4) Wrap other end of strapping (1) around hose (3) and through seal (2). Position strapping on hose about 1 inch from end of hose.
- (5) Wrap another loop of strapping (1) around hose (3) and through seal (2).
- (6) Position strapping (1) in slots of clamping tool (4). Tool nose (5) should fit snug against seal (2).
- (7) Apply pressure to gripper lever (6) and turn handle (7) until strapping (1) is snug. Tool will lock in place when correct tension is applied. Reposition tool as required.

CAUTION

Strapping can damage hose if over tightened.

- (8) Turn handle (7) clockwise to tighten strapping (1) Continue turning handle until strapping stops moving through seal (2)

CAUTION

Strapping may break if operator does not release tension on handle when bending over seal.

- (9) While reversing handle (7) 3/4 turn, roll tool (4) to opposite side of seal (2). (This will bend strapping and prevent it from slipping through seal when tool is removed).
- (10) Pull cutting handle (8) on tool to cut strapping (1).
- (11) Remove tool (4) while holding strapping stub down on seal (2) with thumb.
- (12) Clinch end of strapping (1) by hammering down tabs of seal (2) over strapping stub.
- (13) Repeat steps (2) through (12) for three remaining straps (10, 12, and 13). Straps should be 1-inch from end of hose and 1-inch apart.

4-17. DISCHARGE AND SUCTION HOSE REPAIR - cont

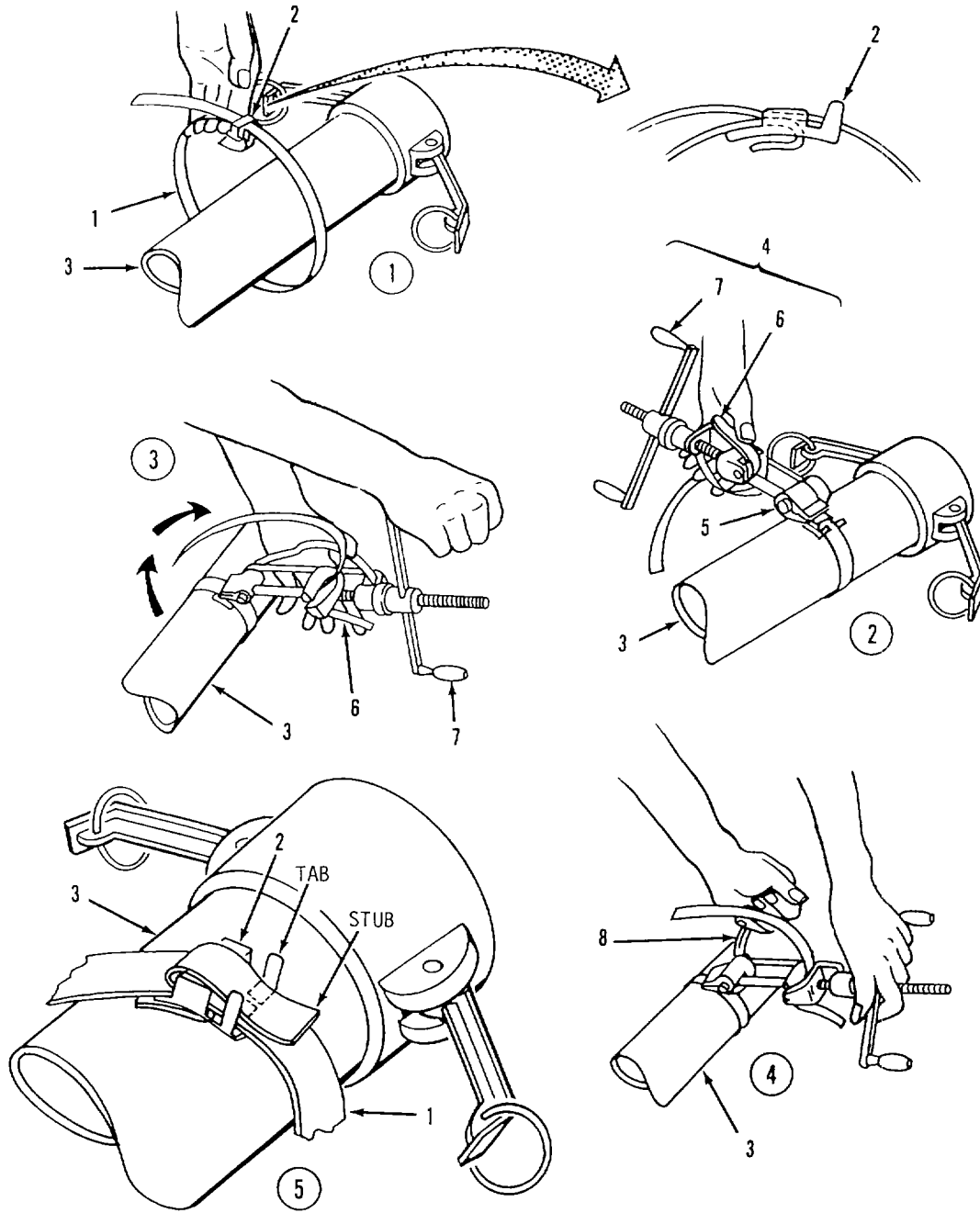

Figure 4-7. Strapping and Seal Installation.

4-17. DISCHARGE AND SUCTION HOSE REPAIR - cont.**CAUTION**

Ensure gasket is fully seated in gasket seat of coupling/dust cap to prevent leaks in assembled components.

- (14) Install gasket (8, figure 4-8) in female coupling (2).
- (15) Install gasket (7) in dust cap (6).
- (16) Connect split ring (4) to male coupling (5) Install dust cap (6) on coupling.
- (17) Connect split ring (1) to female coupling (2) Install dust plug (3) on coupling.
- (18) Install hose in water system (para 3-4b).
- (19) Startup water system (para 2-13c) and test repaired hose for leaks.

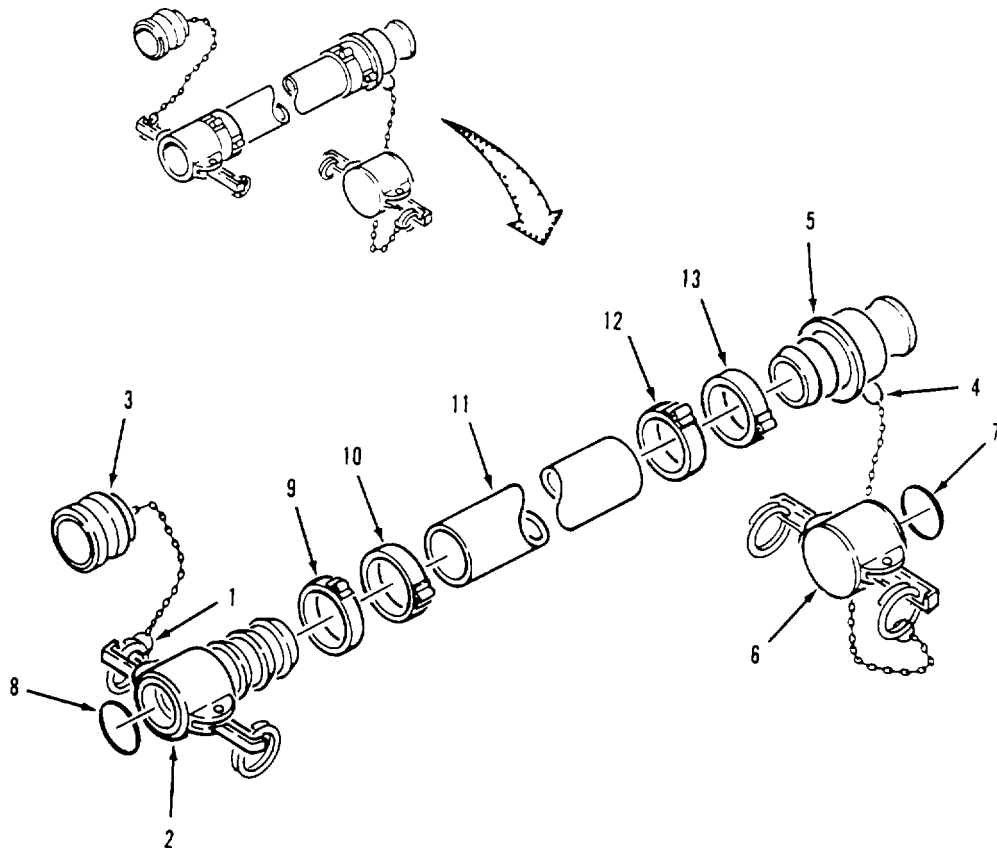

Figure 4-8. Discharge and Suction Hose Assembly.

4-18. WATER METER ASSEMBLY REPAIR.

This task consists of **a. Disassembly** **b. Cleaning** **c. Inspection**
 d. Repair **e. Assembly**

INITIAL SET-UP:

<p>Tools: General Mechanics Tool Kit (Item 1, App B) Pipe Wrench (Item 2, App B)) Vice (Item 2, App B)</p> <p>Equipment Condition: Water meter assembly removed (para 3-4a) Packing (Item 18, App I) Self Locking Nut (16) (Item 40, App I)</p>	<p>Material/Parts: Detergent, General Purpose (Item 1, App E) Wiping Rag (Item 2, App E) Tape, Anti-seize (Item 4, Appendix E) Gasket (2) (Item 2, App I) Gasket, Flange (2) (Item 17, App I)</p>
---	---

NOTE

Ensure that all parts identified as mandatory replacement parts are discarded and replaced with new components

- a. Disassembly Refer to figure 4-9.
- (1) Disconnect ring (1) from male coupling (9) and remove cap (3).
 - (2) Remove gasket (2) from cap (3).
 - (3) Remove eight self locking nuts (4) and screws (5).
 - (4) Separate male coupling (6) and gasket (7) from meter (15).
 - (5) Disconnect ring (8) from female coupling (13) and remove plug (9).
 - (6) Remove gasket (10) from female coupling (13).
 - (7) Remove eight self locking nuts (11) and screws (12).
 - (8) Separate female coupling (13) and gasket (14) from meter (15).
 - (9) If required, remove female coupling end (16) and nipple (17) from adapter (18).
 - (10) If required, remove male coupling end (19) and nipple (20) from adapter (21).
 - (11) Remove ten bolts (22) and lift metering element (23) from body (25).
 - (12) Remove packing (24) from body (25).

4-18. WATER METER ASSEMBLY REPAIR - cont.

c. Cleaning.

- (1) Wash all components with clean water and detergent.
- (2) Rinse components in clean water and dry with wiping rag.

d. Inspection.

- (1) Inspect female coupling end (16), male coupling end (19) and adapters (18 and 21) for cracks, stripped threads, and corrosion.
- (2) Inspect body (25) for cracks and corrosion.
- (3) Inspect metering element (23) for cracks, damage, and corrosion.

e. Repair. Replace damaged or defective parts. Replace all sealing components.

f. Assembly. Refer to figure 4-9.

NOTE

Ensure packing is fully seated in groove of body.

- (1) Position packing (24) in body (25).
- (2) Lower metering element (23) onto body (25). Make sure arrow on top of element is pointing in the same direction as the arrow on the body.
- (3) Install ten bolts (22) in metering element (23).

NOTE

Ensure that anti-seize tape is applied in the same direction as the threads.

- (4) If removed, apply anti-sieze tape to male threads of nipple (20). Install male coupling end (19) and nipple (20) on adapter (21).
- (5) If removed, apply anti-sieze tape to male threads of nipple (17). Install nipple and female coupling end (16) on adapter (18)
- (6) Position gasket (14) and female coupling (13) on meter (15).
- (7) Install eight screws (12) and self locking nuts (11).

NOTE

Ensure gasket is fully seated in groove of coupling.

- (8) Install gasket (10) in female coupling (13).
- (9) Connect plug (9) to female coupling (13) with ring (8).

4-18. WATER METER ASSEMBLY REPAIR - Cont.

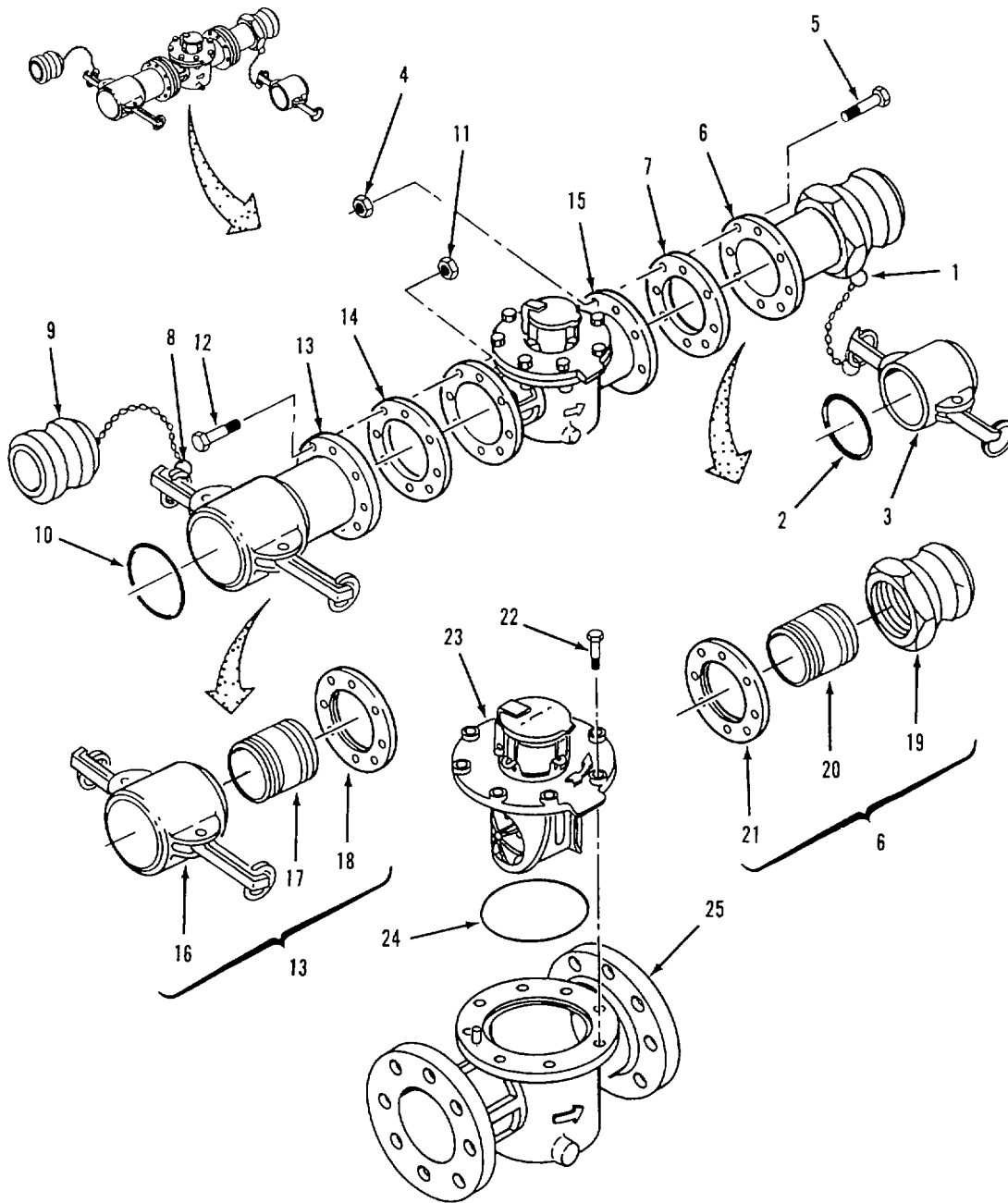

Figure 4-9. Water Meter Repair.

4-18. WATER METER ASSEMBLY REPAIR - cont.

- (10) Position gasket (7) and male coupling (6) on meter (15).
- (11) Install eight screws (5) and self locking nuts (4).

NOTE

Ensure packing is fully seated in groove of cap.

- (12) Install gasket (2) in cap (3).
- (13) Connect cap (3) to male coupling (6) with ring (1).
- (14) Install water meter assembly in water system (para 3-4b).
- (15) Startup water system (para 2-13c) and check water meter assembly for leaks.

14-19. NOZZLE STAND ASSEMBLY REPAIR.

This task consists of. **a. Disassembly** **b. Cleaning** **c. Inspection**
 d. Repair **e. Assembly**

INITIAL SET-UP:

<p>Tools: General Mechanics Tool Kit (Item 1, App B)</p>	<p>Material/Parts: Detergent, General Purpose (Item 1, App E) Wiping Rag (Item 2, App E) Cotter Pin (2) (Item 20, App I)</p>
--	--

NOTE

Ensure that all parts identified as mandatory replacement parts are discarded and replaced with new components

- a. Disassembly. Refer to figure 4-10.
 - (1) Unbend and remove S-hooks (1, 3 and 5) and disconnect chains (2, 4 and 6).

4-19. NOZZLE STAND ASSEMBLY REPAIR - cont.

(2) Remove cotter pin (7) and straight pin (8), then remove leg (11) from leg (13).

(3) Remove cotter pin (10) and straight pin (9), then remove leg (12) from leg (13).

b. Cleaning.

(1) Wash all components with clean water and detergent.

(2) Rinse components in clean water and dry with wiping rag.

c. Inspection.

(1) Inspect legs (11, 12 and 13) for cracks, broken clevis ends and bent or missing nozzle hangers.

(2) Inspect chains (2, 4 and 6) for broken links.

d. Repair. Replace defective components.

e. Assembly. Refer to figure 4-10.

(1) Position clevis fitting on leg (13) over pivot fitting on leg (12).

(2) Install straight pin (9) through pivot fitting and clevis. Install cotter pin (10) in straight pin.

(3) Align clevis fitting on leg (13) with pivot fitting on leg (11).

(4) Install straight pin (8). Install cotter pin (7) in straight pin.

(5) Connect chains (2, 4, and 6) to legs (11, 12, and 13) with S-hooks (1, 3 and 5).

(6) Position nozzle stand in water system.

4-19. NOZZLE STAND ASSEMBLY REPAIR.

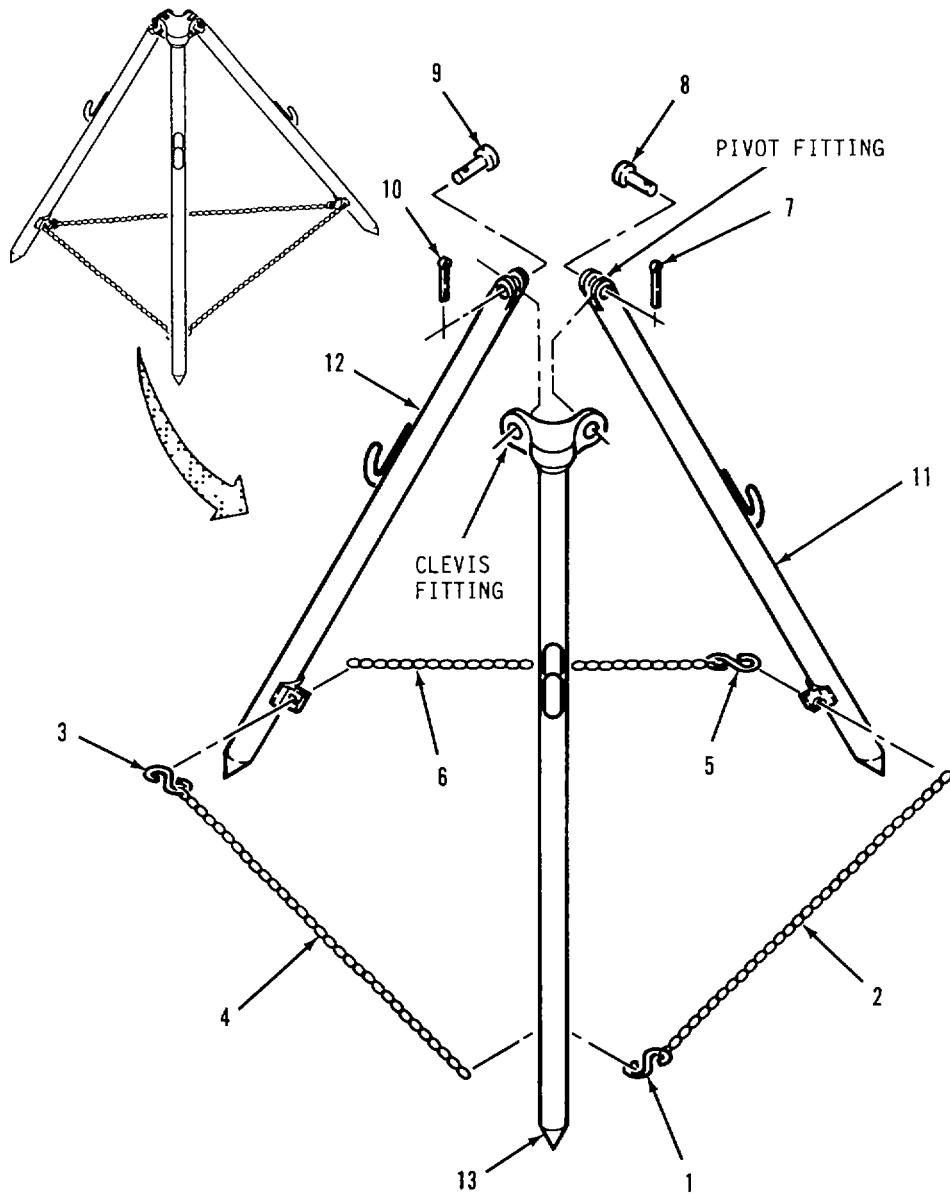

Figure 4-10. Nozzle Stand Repair.

4-20. STORAGE ASSEMBLY MAINTENANCE.

The storage assembly consists of the components listed below Refer to the following paragraphs for applicable maintenance procedures.

Procedure	Para.
Gate Valve Assembly (4-Inch) Repair.....	4-21
Suction and Discharge Hose Repair.....	4-17

4-21. GATE VALVE ASSEMBLY (4-INCH) REPAIR.

This task consists of:

- | | | |
|-----------------------|--------------------|----------------------|
| a. Disassembly | b. Cleaning | c. Inspection |
| d. Repair | e. Assembly | |

INITIAL SETUP:

Tools:

General Mechanics Tool Kit (Item 1, App B)

Equipment Condition:

4-inch gate valve assembly removed (para 3-4a)

Material/Parts:

Detergent, General Purpose (Item 1, App E)

Wiping Rag (Item 2, App E)

Tape, Anti-seize (Item 4, Appendix E)

Casket (2) (Item 2, App I)

Gasket (3) (Item 17, App I)

Lockwasher (16) (Item 16, App I)

Packing Ring (Item 21, App I)

Flange Gasket (Item 22, App I)

Lockwasher (8) (Item 23, App I)

NOTE

Ensure that all parts identified as mandatory replacement parts are discarded and replaced with new components.

a. Disassembly.

Remove gate valve Refer to figure 4-11

- (1) Remove eight nuts (1), lockwashers (2), flat washers (3), screws (4) and flat washers (5).
- (2) Separate male coupling (6) and gasket (7) from gate valve (16).
- (3) Remove gasket (8) from female coupling (14).
- (4) Remove eight nuts (9), lockwashers (10), flat washers (11), screws (12) and flat washers (13).
- (5) Separate female coupling (14) and gasket (15) from gate valve (16).

4-21. GATE VALVE ASSEMBLY (4-INCH) REPAIR.

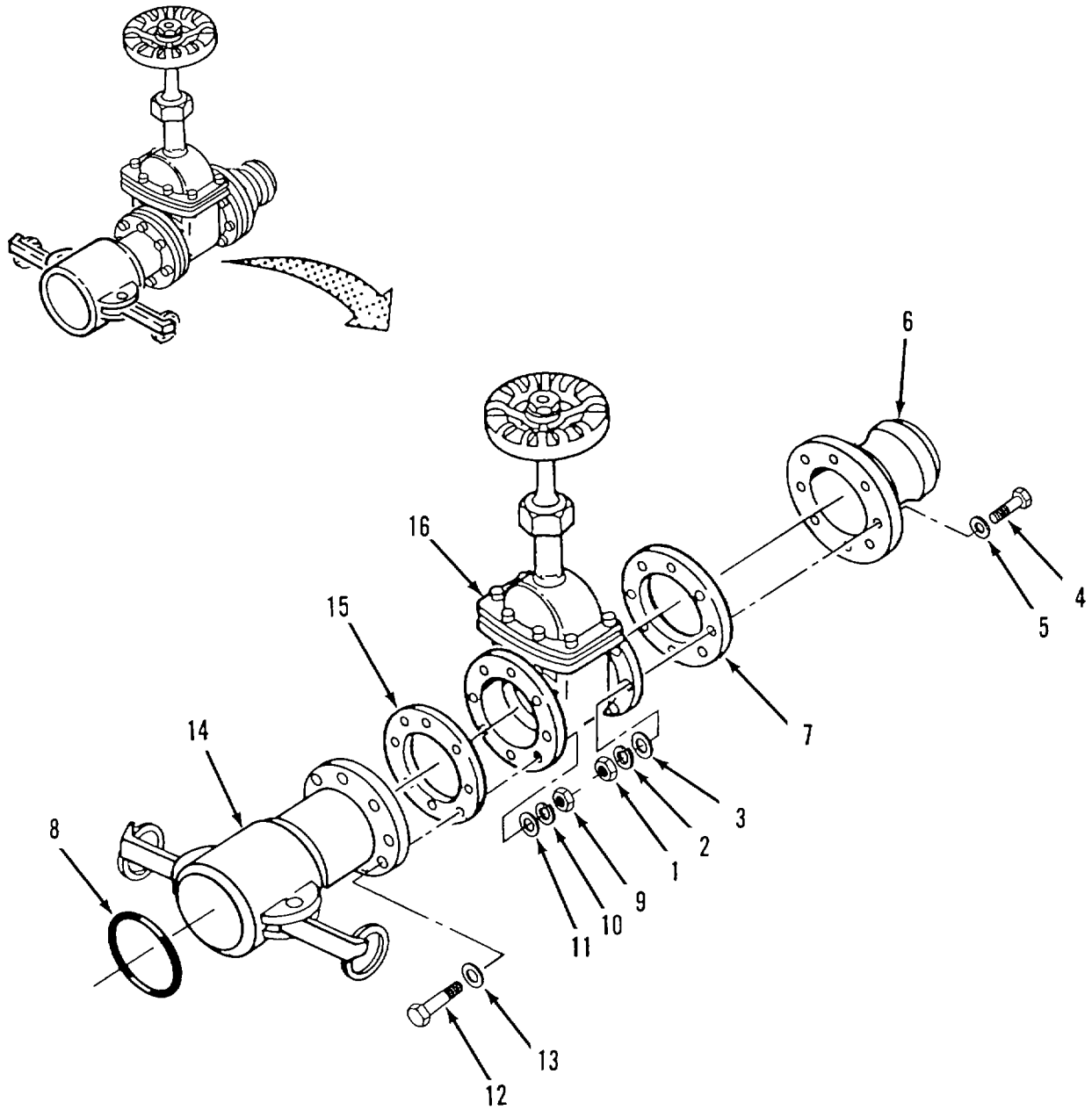

Figure 4-11. Gate Valve (4-inch) Disassembly

4-21. GATE VALVE ASSEMBLY (4-INCH) REPAIR - cont.

Disassemble gate valve Refer to figure 4-12.

- (6) Remove nut (1) and handwheel (2) from stem (13).
- (7) Remove packing nut (3), gland spring (4), packing gland (5) and packing ring (6) from top of bonnet (11).
- (8) Remove eight nuts (7), lockwashers (8), screws (9) and fiat washers (10) from valve body (18) and bonnet (11).

NOTE

If needed, tap bonnet with mallet to loosen sealing surfaces.

- (9) Remove bonnet (11), gasket (12), and attached parts from valve body (18).
- (10) Remove two screws (14) and separate discs (15 and 16) from disc riser (17).
- (11) Remove disc riser (17) from stem (13).
- (12) Unscrew stem (13) from bottom of bonnet (11).

b. Cleaning

- (1) Wash all components with clean water and detergent.
- (2) Rinse components in clean water and dry with wiping rag.

c. Inspection

- (1) Inspect bonnet (11) and valve body (18) for cracks, scored mating surfaces, stripped threads and corrosion.
- (2) Inspect for bent stem (13) and galled or stripped threads.
- (3) Inspect sealing surfaces of discs (15 and 16) and valve body (18) for deep scratches and cracks.
- (4) Inspect male coupling (6, figure 4-11) for cracks and corrosion
- (5) Inspect female coupling (14) for cracks and broken locking arms

d. Repair. Replace damaged or defective parts Replace all sealing components

4-21. GATE VALVE ASSEMBLY (4-INCH) REPAIR - cont. I

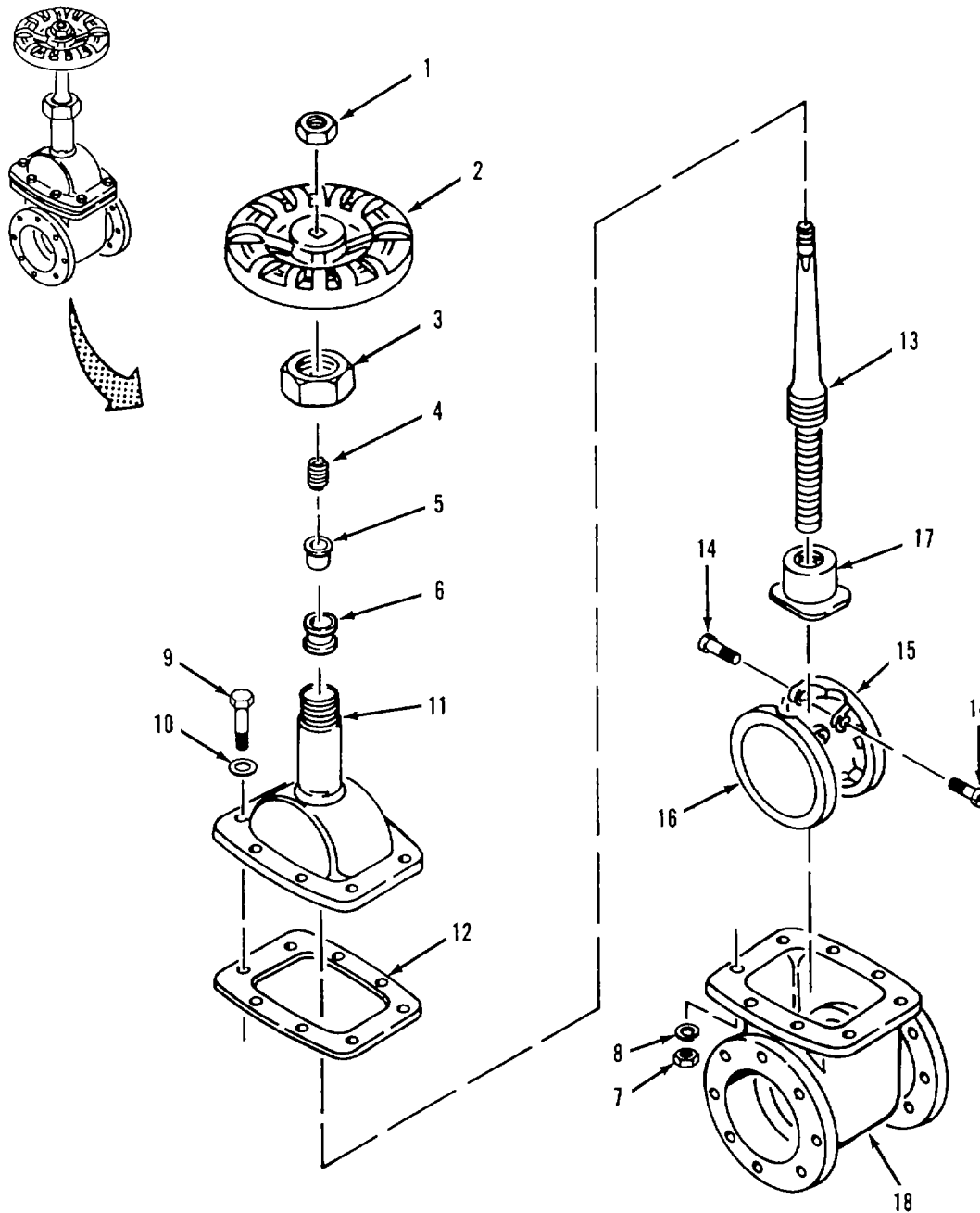

Figure 4-12. Gate Valve (4-Inch) Repair.

Figure 4-12.

4-21. GATE VALVE ASSEMBLY (4-INCH) REI'AI R - cont.e. Assembly.

Assemble gate valve. Refer to figure 4-12.

- (1) Screw stem (13) all the way into bottom of bonnet (11), then back out stem three full turns. Do not allow stem to move from this position.
- (2) While holding stem (13) in place, screw disc riser (17) onto stem until bottom of riser is flush with end of stem.
- (3) Position discs (15 and 16) on riser (17) and install two screws (14).
- (4) While preventing stem (13) from turning in bonnet (11), turn discs (15 and 16) and riser (17) left (counterclockwise) onto stem until top of discs contact flanged bottom of bonnet.
- (5) Position gasket (12) on valve body (18).
- (6) While holding stem (13) in position, lower bonnet (11) and discs (15 and 16) into valve body (18). Do not rotate discs more than 1/4 turn to align discs with body.
- (7) Install eight flat washers (10), screws (9), lockwashers (8) and nuts (7) in valve body (18) and bonnet (11).
- (8) Slide packing ring (6) over stem (13) and down into bonnet (11).
- (9) Slide packing gland (5) and gland spring (4) over stem (13).
- (10) Slide packing nut (3) over stem (13) and tighten onto top of bonnet (11).
- (11) Position handwheel (2) on stem (13) and secure with nut (1).

Install gate valve. Refer to figure 4-11.

NOTE

Install female coupling with locking arms positioned as shown.

- (12) Position gasket (15) and female coupling (14) on gate valve (16).
- (13) Install eight flat washers (13), screws (12), flat washers (11), lockwashers (10) and nuts (9).

NOTE

Ensure gasket is fully seated in groove of coupling.

- (14) Install gasket (8) in female coupling (14).

4-21. GATE VALVE ASSEMBLY (4-INCH) REPAIR - cont.

- (15) Position gasket (7) and male coupling (6) on gate valve (16).
- (16) Install eight flat washers (5), screws (4), flat washers (3), lockwashers (2) and nuts (1).
- (17) Install gate valve in water system (para 3-4b).
- (18) Startup water system (para 2-13c) and check gate valve for leaks.

4-22. SUSPENSION ASSEMBLY MAINTENANCE.

Maintenance of the suspension assembly is limited to replacing worn, damaged or missing suspension kit components. Unit level repair of the storage chest is contained in para 4-23.

4-23. STORAGE CHEST REPAIR

This task consists of:

a. Disassembly
d. Repair

b. Cleaning
e. Assembly

c. Inspection

INITIAL SETUP:**Tools:**

General Mechanics Tool Kit (Item 1, App B)
Drill, Electric (Item 2, App B)
Set, Drill (Item 2, App B)
Riveting Tool (Item 2, App B)

Material/Parts:

Wiping Rag (Item 2, App E)
Rivet (40) (Item 24, App I)

NOTES

- Ensure that all parts identified as mandatory replacement parts are discarded and replaced with new components.
- Disassemble storage chest only to the extent required to replace defective parts.

a. Disassembly. Refer to figure 4-13.

Cover Disassembly

- (1) Unlatch four lower clasps (11) and lift cover (5).
- (2) Using pliers, open two S-hooks(1) and disconnect chains (3) from cover (5).
- (3) Using pliers, open two S-hooks (2) and remove chains (3) from bottom (12).
- (4) Close cover (5)
- (5) Using electric drill and drill bit, remove twelve rivets (4) securing cover (5) to hinge (7).
- (6) Using electric drill and drill bit, remove two rivets (8) and upper clasp (9) from cover (5). Repeat for three remaining upper clasps.

Bottom Disassembly

- (7) Using electric drill and drill bit, remove two rivets (10) and lower clasp (11) from bottom (12). Repeat for three remaining lower clasps.
- (8) Using electric drill and drill bit, remove twelve rivets (6) securing hinge (7) to bottom (12).

b. Cleaning. Use wiping rag to remove grease and dirt from cover (5) and bottom (12).

c. Inspection. Inspect cover (5) and bottom (12) for cracks, broken welds, large dents and corrosion.

d. Repair. Replace damaged or defective components.

4-23. STORAGE CHEST REPAIR - cont.

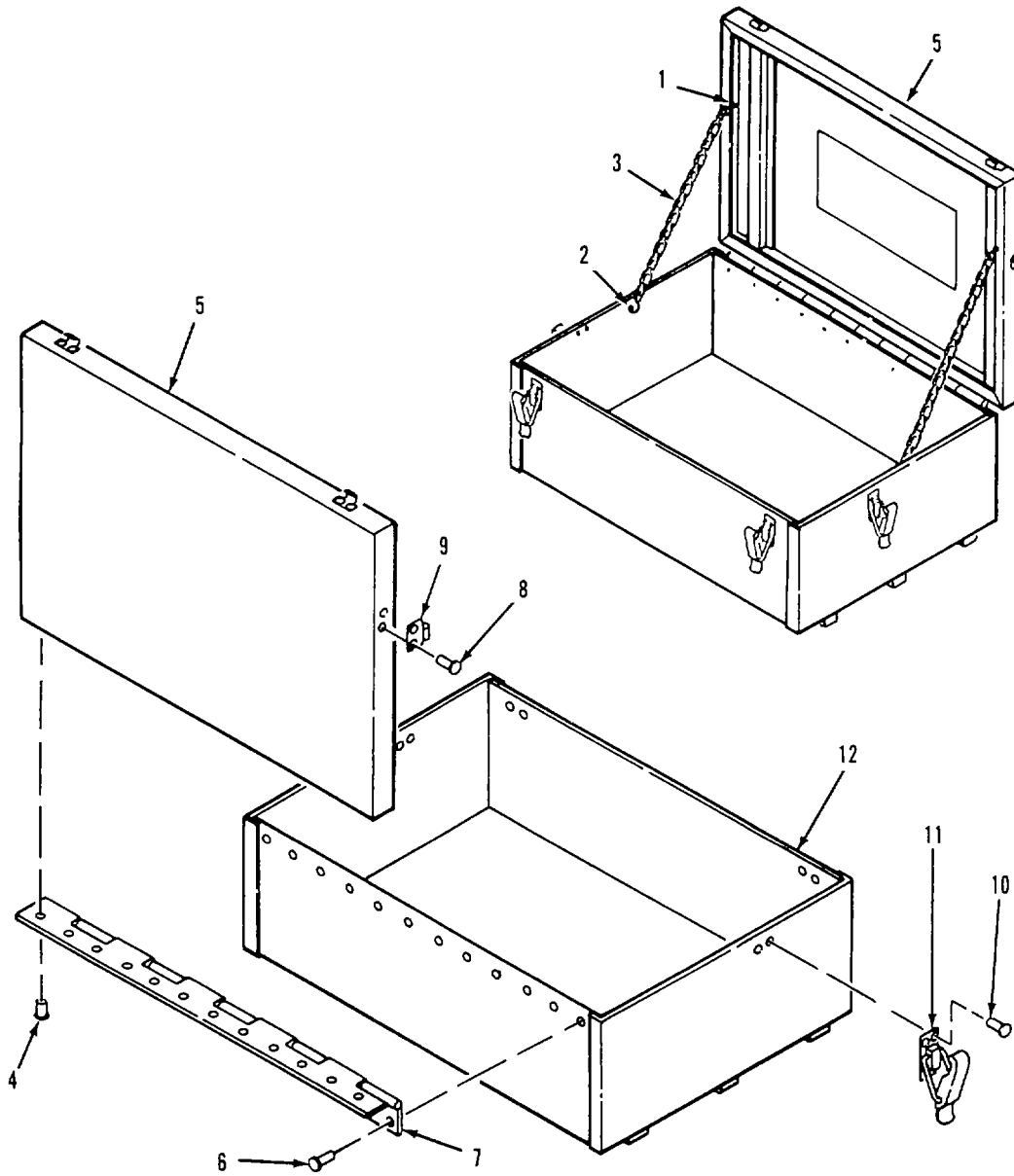

Figure 4-13. Storage Chest Disassembly.

4-23. STORAGE CHEST REPAIR - cont.

e. Assembly. Refer to figure 4-14.

Bottom Assembly

- (1) Aline hinge (7) with mounting holes in bottom (12) Using rivet tool, secure hinge to bottom with twelve rivets (6).
- (2) Aline lower clasp (11) with mounting holes in bottom (12) Using rivet tool secure lower clasp (11) with to bottom (12) with two rivets (10) Repeat for three remaining lower clasps.
- (3) Aline upper clasp (9) with mounting holes in cover (5) Using rivet tool, secure upper clasp (9) to cover (5) with two rivets (8) Repeat for three remaining upper clasps.

Cover Assembly

- (4) Aline mounting holes in cover (5) with hinge (7). Using rivet tool, secure cover to hinge with twelve rivets (4).
- (5) Connect chains (3) to S-hooks (2) in bottom (12). Using pliers, close S-hooks (2) to retain chains in place.
- (6) Connect other end of chains (3) to S-hooks (1) in cover (5). Using pliers, close S-hooks (1) to retain chains in place.
- (7) Close cover (5) and latch four lower clasps (11).

4-23. STORAGE CHEST REPAIR - cont.

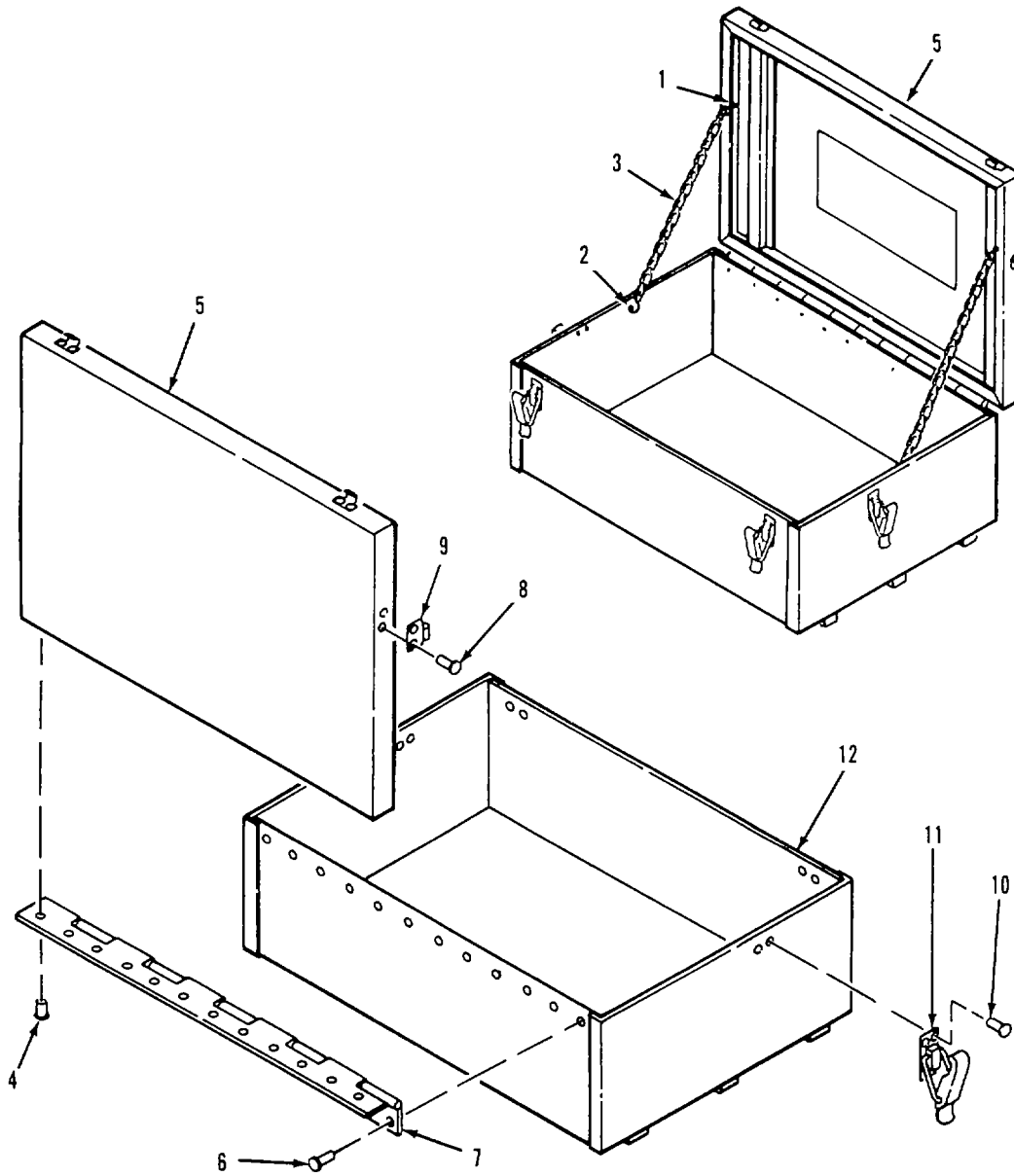

Figure 4-14. Storage Chest Assembly.

4-24. SLING ASSEMBLY REPAIR.

This task consists of:

- | | | |
|----------------|-------------|---------------|
| a. Disassembly | b. Cleaning | c. Inspection |
| d. Repair | e. Assembly | |
-

INITIAL SETUP:**Tools:**

General Mechanics Tool Kit (Item 1, App B)

Material/Parts:

Wiping Rag (Item 2, App E)

NOTE

Disassemble sling only to the extent required to replace defective parts.

- a. Disassembly. Refer to figure 4-15.
- (1) Remove two nuts (1), nuts (2) and flatwashers (3) from u-bolt (4).
 - (2) Remove u-bolt (4) from spreader bar (6).
 - (3) Separate u-bolt (4) from loop in upper sling (5).
 - (4) Remove lower sling (7) from spreader bar (6).
 - (5) Repeat steps (1) through (4) for other end of spreader bar (6).
- b. Cleaning. Using wiping rag, remove dirt and grease from sling components.
- c. Inspection.
- (1) Inspect spreader bar (6) for cracks, enlarged u-bolt mounting holes and corrosion. Inspect for bent spreader bar.
 - (2) Inspect upper and lower slings (5 and 7) for frays, kinks and broken strands of wire. Inspect hooks and rings for cracks.
 - (3) Inspect u-bolt (4) and nuts (1 and 2) for damaged threads and corrosion.
- d. Repair. Replace all damaged or defective components.
- e. Assembly. Refer to figure 4-15.
- (1) Position ring of lower sling (7) over end of spreader bar (6). Center ring between u-bolt mounting holes.
 - (2) Place inside leg of u-bolt (4) through loop in upper sling (5).

4-24. SLING ASSEMBLY REPAIR - cont.

WARNING

To prevent injury to personnel and damage to the equipment, u-bolt must be installed correctly. Ring of lower sling must be positioned between legs of u-bolt as shown.

- (3) Install u-bolt (4) in spreader bar (6).

NOTE

Nuts used to attach u-bolt are two different sizes. The thicker nuts are installed first, followed by the thinner nuts.

- (4) Install two flat washers (3) and nuts (2) on u-bolt (3). Tighten securely.
- (5) Install two nuts (1) on top of nuts (2). Tighten securely.
- (6) Repeat steps (1) through (5) for other end of spreader bar (5).

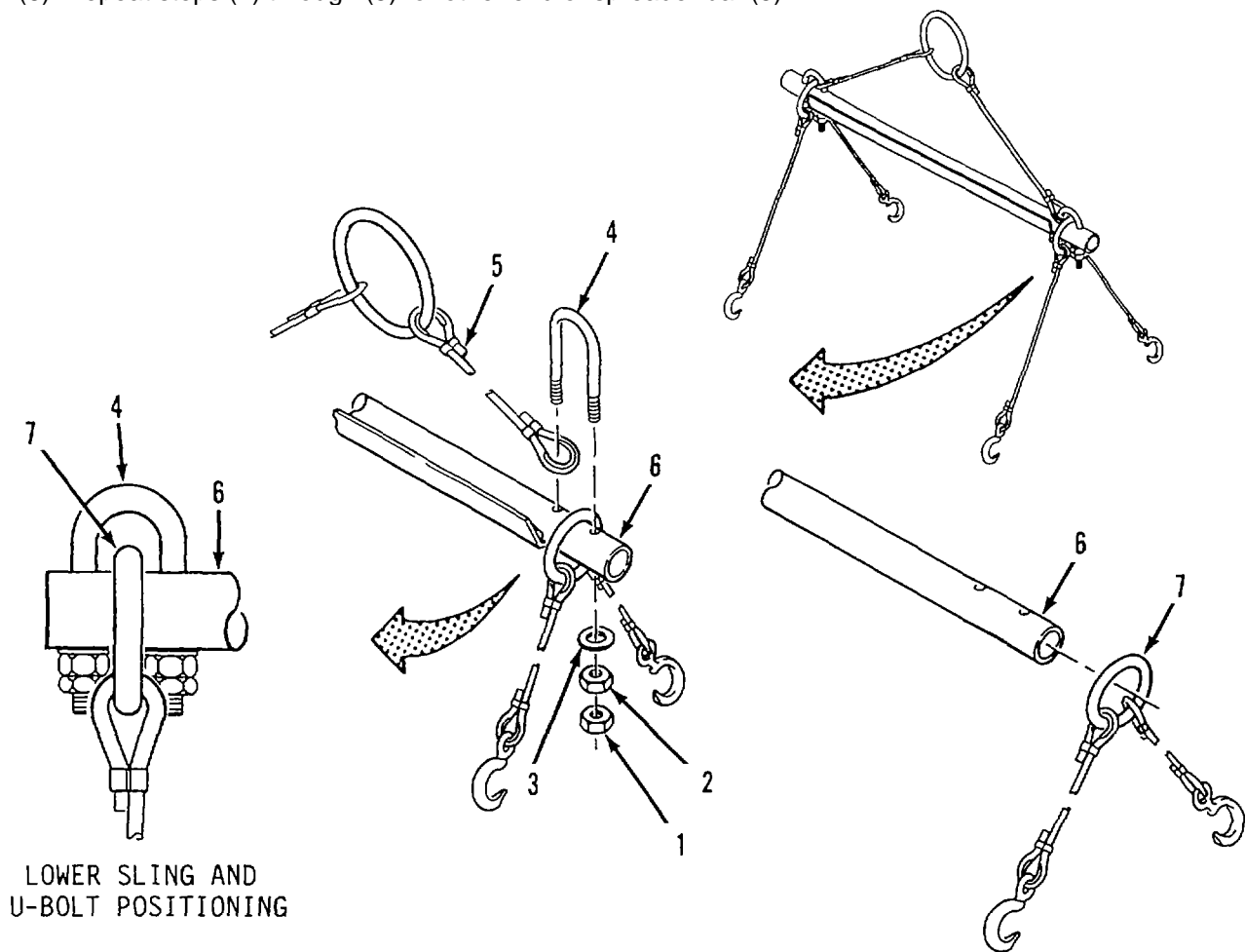

Figure 4-15. Sling Repair

4-25. FLAKING BOX ASSEMBLY MAINTENANCE.

The flaking box assembly consists of the components listed below Refer to the following paragraphs for applicable maintenance procedures.

Procedure	Para.
Flaking Box Repair.....	4-26
Discharge Hose (6-Inch) Repair.....	4-17

4-26. FLAKING BOX REPAIR.

This task consists of:

- | | | |
|-----------------------|--------------------|----------------------|
| a. Disassembly | b. Cleaning | c. Inspection |
| d. Repair | e. Assembly | |

INITIAL SETUP:

Tools:

General Mechanics Tool Kit (Item 1, App B)

Equipment Condition :

Hoses removed or deployed

Material/Parts:

Detergent, General Purpose (Item 1, App E)

Wiping Rag (Item 2, App E)

Cotter Pin (Item 25, App I)

NOTE

Ensure that all parts identified as mandatory replacement parts are discarded and replaced with new components.

- a. Disassembly. Refer to figure 4-16.
 - (1) Remove cotter pin (1) from clevis pin (2).
 - (2) Remove clevis pin (2) from bracket (4).
 - (3) Separate clevis (3) from bracket (4).
 - (4) Repeat steps (1) through (3) for three remaining brackets (4).

- b. Cleaning.
 - (1) Wash flaking box interior and exterior with clean water and detergent.
 - (2) Rinse flaking box with clean water and dry with wiping rag.

- c. Inspection.
 - (1) Inspect interior and exterior of flaking box (5) for cracks, broken welds and bent or crushed frame members.
 - (2) Inspect clevis, (3), clevis pins (2) and brackets (4) for cracks and signs of wear.

- d. Repair. Replace damaged or defective components

4-26. FLAKING BOX REPAIR- cont.

e. Assembly. Refer to figure 4-16.

- (1) Position and align clevis (3) on bracket (4).
- (2) Install clevis pin (2) through clevis (3) and bracket (4). Make sure clevis pin is installed with flat side of head against flaking box (5).
- (3) Install cotter pin (1) in clevis pin (2).
- (4) Repeat steps (1) through (3) for three remaining brackets (4).

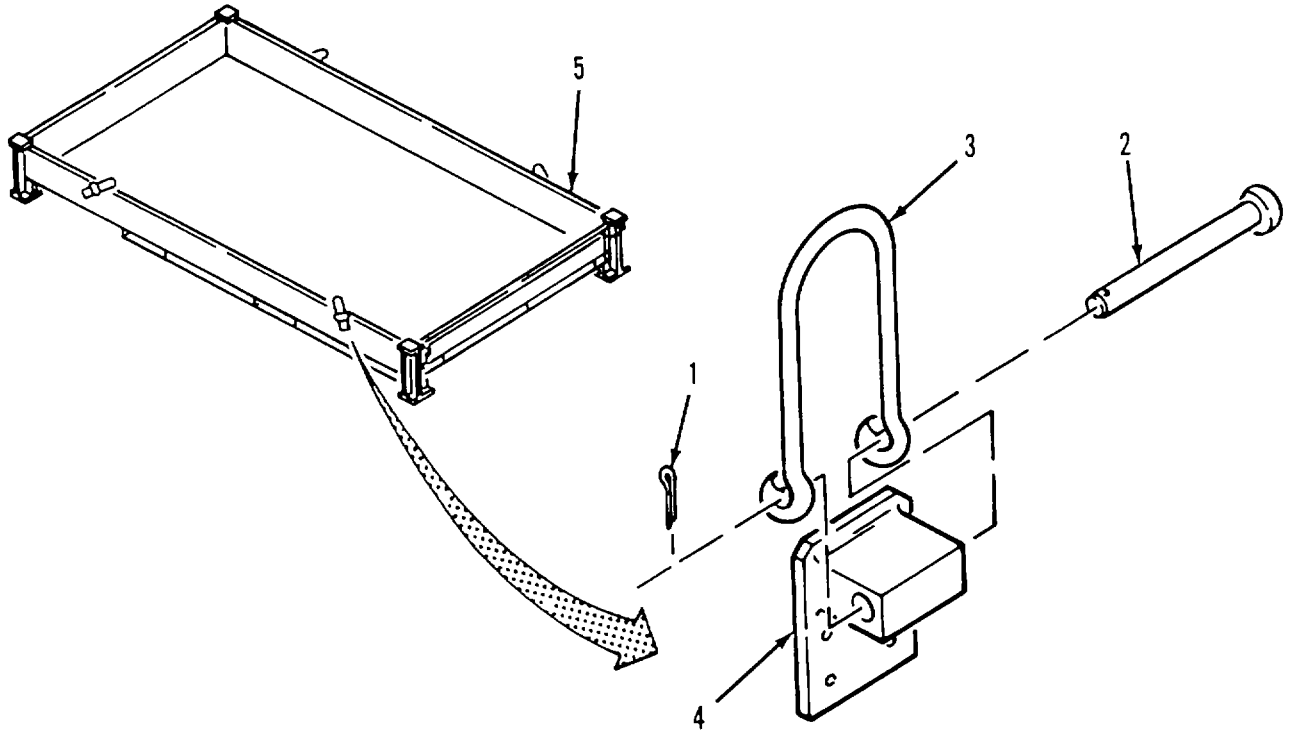

Figure 4-16. Flaking Box Repair

4-27. PRESSURE REGULATING VALVE REPAIR.

This task consists of:

- | | | |
|----------------|-------------|---------------|
| a. Disassembly | b. Cleaning | c. Inspection |
| d. Repair | e. Assembly | |

INITIAL SETUP :**Tools:**

General Mechanics Tool Kit (Item 1, App B)
 Pipe Wrench (Item 2, App B)
 Vice (Item 2, App B)
 Lifting Device
 Eyebolt. 3/4 inch

Equipment Condition :

Pressure regulating valve removed from water system (para 3-4a)

- a. Disassembly.

Materials/Parts:

Detergent, General Purpose (Item 1, App E)
 Wiping Rag (Item 2, App E)
 Anti-seize (Item 4, App E)
 Diaphragm (Item 26, App I)
 Packing (Item 27, App I)
 Disc (Item 28, App I)

NOTE

To aid disassembly, loosen eight nuts (3, figure 4-19) on cover before removing pressure regulating valve from frame.

Remove Valve. Refer to figure 4-17.

- (1) Remove two nuts (1), bolts (2) and flat washers (2) from bracket (6).
- (2) Remove two bolts (4), flat washers (5), and bracket (6) from top of pressure regulating valve (9).
- (3) Repeat steps (1) and (2) for bracket (6) on other side of pressure regulating valve (9).
- (4) If required, remove plug (7) from top of pressure regulating valve (9) and install 3/4-inch eyebolt (8).

WARNING

Pressure regulating valve is heavy/difficult to handle. To prevent injury to personnel use a lifting device to remove valve from frame.

NOTE

Pressure regulating valve must be repositioned during removal to clear sides of frame.

- (5) Using lifting device, carefully hoist pressure regulating valve (9) from frame (10). Turn valve as required to clear sides of frame.

4-27. PRESSURE REGULATING VALVE REP'AIR - cont.

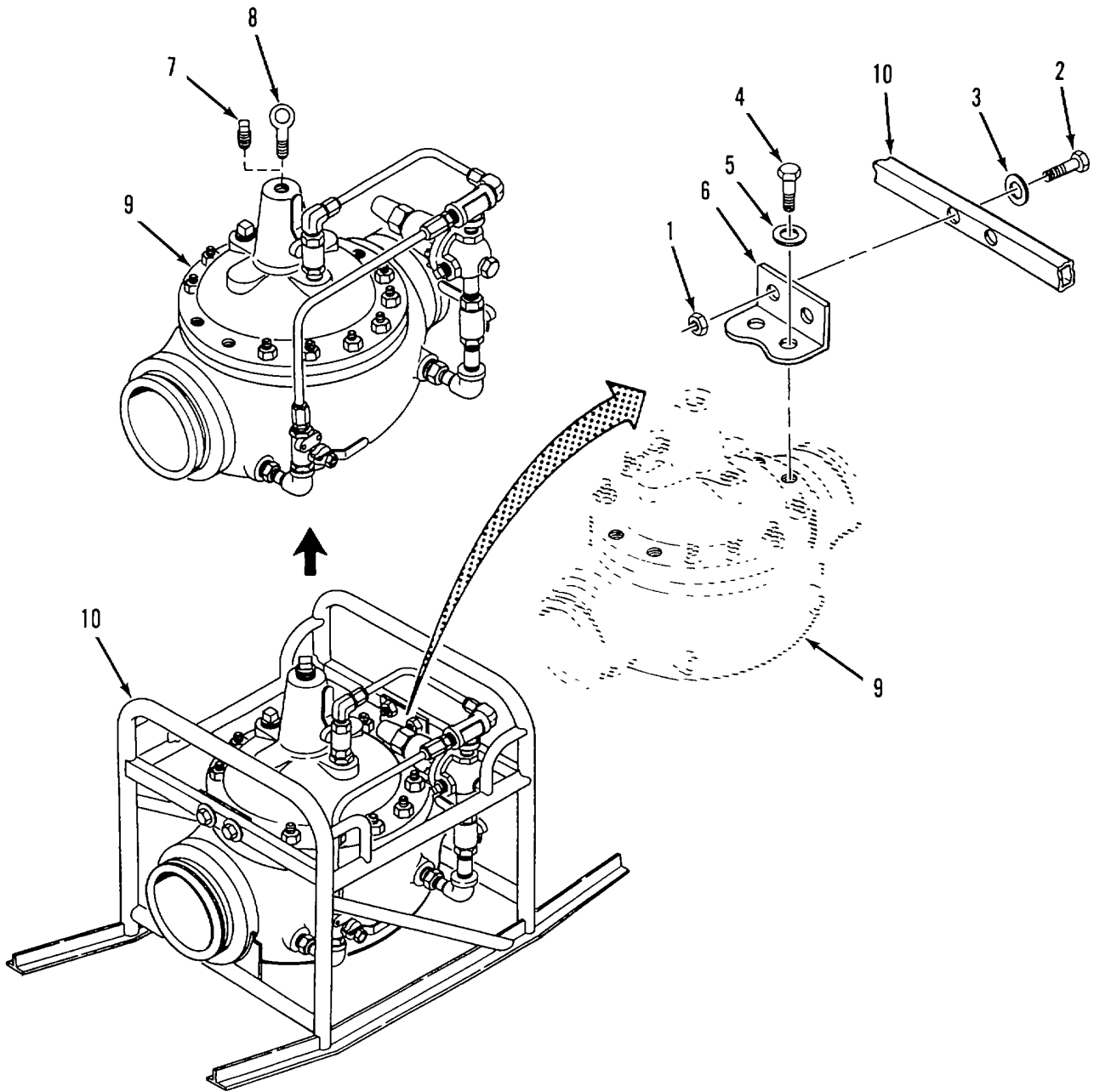

Figure 4-17. Pressure Regulating Valve Removal.

4-27. PRESSURE REGULATING VALVE REPAIR - cont.**NOTE**

Disassemble piping only to the extent required to replace defective component(s).

Disassemble Inlet. Piping Refer to figure 4-18.

- (6) Disconnect both ends of line (1) and remove from valve (24).
- (7) Disconnect both ends of line (2) and remove from pressure regulating valve (24).
- (8) Unscrew connector (3) from valve (4).
- (9) Turn handle of valve (4) in line with valve body (open position).
- (10) Unscrew valve (4) from 1-inch nipple (5).
- (11) Unscrew 1-inch nipple (5), elbow (6), 2-inch nipple (7) and strainer (8) from pressure regulating valve (24).

Disassemble Outlet Piping. Refer to figure 4-18.

- (12) Unscrew elbow (9) and restrictor (10) from tee (11).
- (13) Unscrew 1-inch nipple (12) and regulating valve (13) from 3-inch nipple (14).
- (14) Turn handle of valve (15) in line with valve body (open position).
- (15) Unscrew 3-inch nipple (14), valve (15), and 2 1/2-inch nipple (16) from elbow (17).
- (16) Unscrew elbow (17), 1 1/2 inch nipple (18) and bushing (19) from pressure regulating valve (24).

Disassemble Bypass Piping. Refer to figure 4-18.

- (17) Turn handle of valve (21) in line with valve body (open position).
- (18) Unscrew elbow (20) and valve (21) from 1-inch nipple (22).
- (19) Unscrew 1-inch nipple (22) and bushing (23) from pressure regulating valve (24).

4-27. PRESSURE REGULATING VALVE REPAIR - cont.

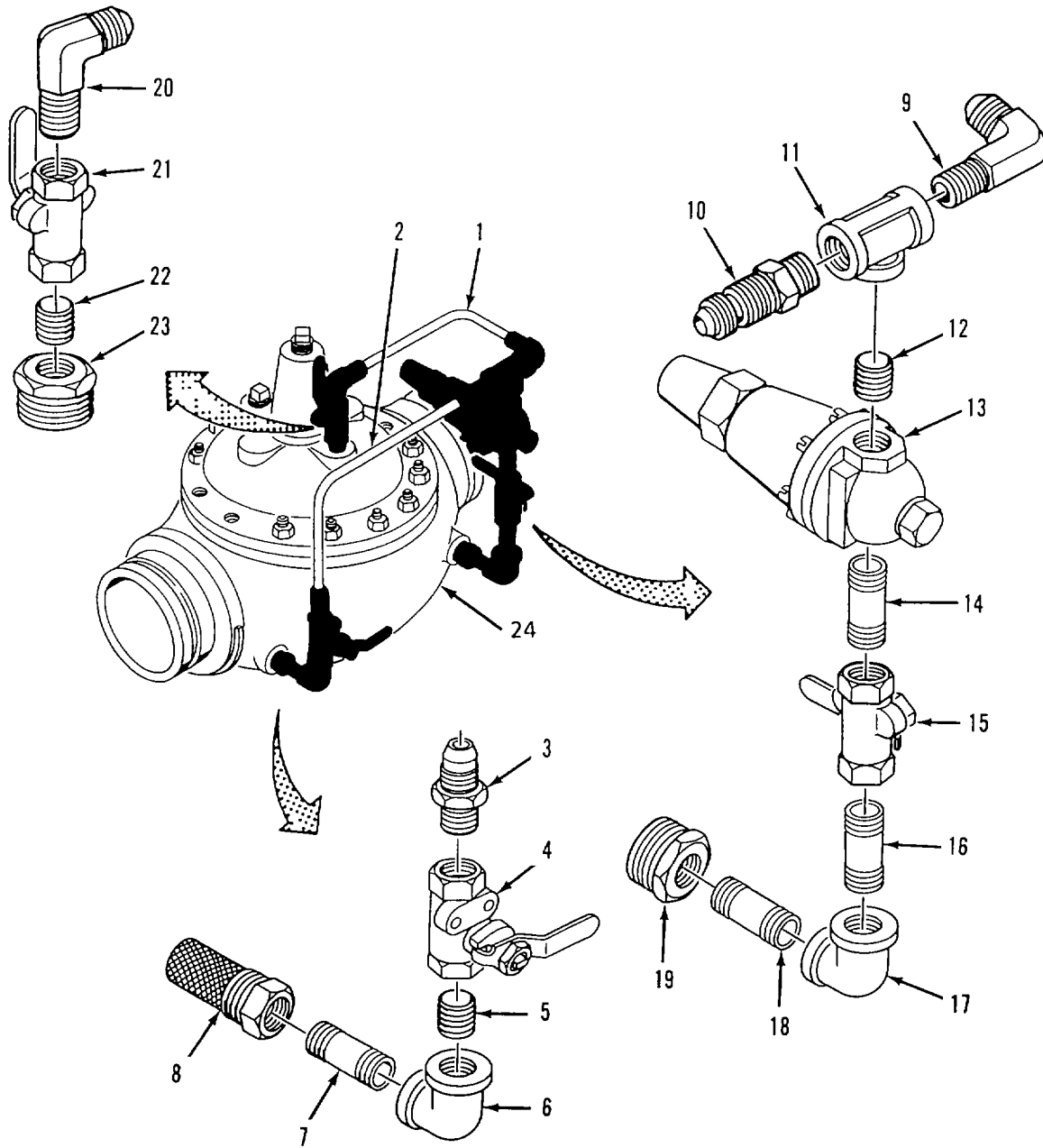

Figure 4-18. Pressure Regulating Valve Piping Removal.

4-27. PRESSURE REGULATING VALVE REPAIR - cont.

Disassemble Pressure Regulating Valve. Refer to figure 4-19.

- (20) Mark and record alinement of cover (4) with body (20).
- (21) Remove plug(l) from cover (4).
- (22) Screw 3/4-inch eyebolt (2) into hole in cover (4).
- (23) Connect lifting device to eyebolt (2).

WARNING

To prevent injury to personnel, remove cover slowly to release spring tension.

- (24) Remove eight nuts (1) from cover (4).

CAUTION

To prevent damage to bearing cover or valve stem, pull cover straight up from body.

- (25) Using Lifting device, lift cover (4) off valve body (20). If cover is stuck, use a hammer and blunt chisel to drive cover up off body by tapping upward around edge of cover.
- (26) If required, remove cover bearing (6) from cover (4).
- (27) Remove spring (7) from top of stem (15).

CAUTION

To prevent damage to stem or seat, pull stem straight up from body.

- (28) Remove assembled diaphragm (5) from body (20).

CAUTION

To prevent damage to stem, use vice that has soft brass jaws.

- (29) Secure end of stem (15) (opposite end of nut (8)) in vice.
- (30) Remove nut (8), diaphragm washer (9) and diaphragm (10) from stem (15).
- (31) Remove disc retainer (11) and disc (12) from stem (15) Using screwdriver, separate disc retainer from disc.
- (32) Remove spacer washer (13) and disc guide (14) from stem (15).
- (33) If required, remove seat (16) and packing (17) from body (20).
- (34) Remove plug (18) from cover (4).
- (35) Remove two plugs (19) from body (20).

4-27. PRESSURE REGULATING VALVE REPAIR - cont.

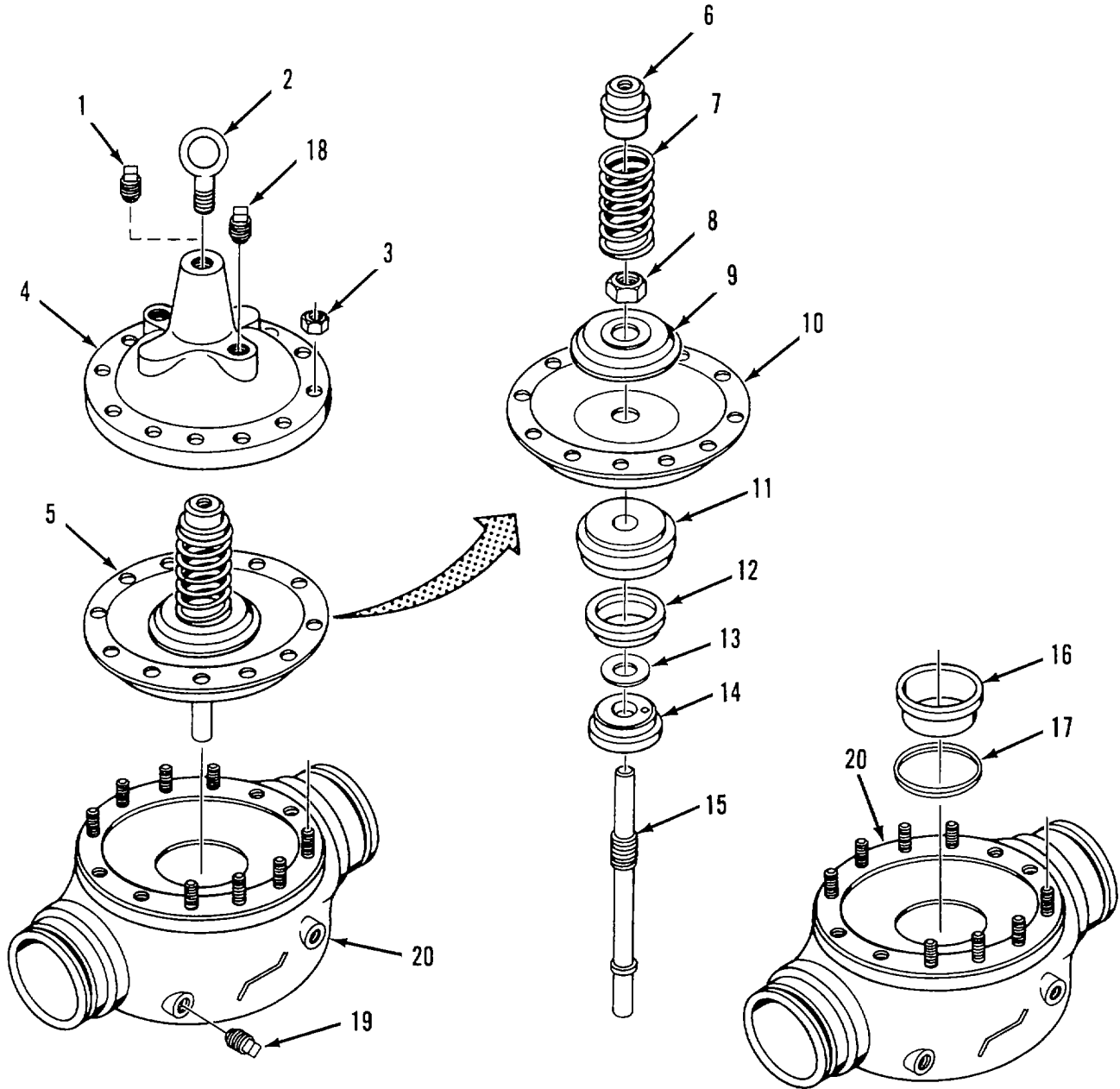

Figure 4-19. Pressure Regulating Valve Disassembly.

4-27. PRESSURE REGULATING VALVE REPAIR - cont.b. Cleaning.

- (1) Using wire brush, remove corrosion and water deposits from threaded components.
- (2) Wash all components with clean water and detergent. Make sure all water deposits are removed.
- (3) Rinse components in clean water and dry with wiping rag.

c. Inspection.

- (1) Inspect body (20, figure 4-19) for cracks, corrosion and stripped or damaged threads.
- (2) Inspect stem (15) for cracks, scratches or damaged threads.
- (3) Inspect cover bearing (6), disc retainer (11), disc guide (14) and seat (16) for cracks, corrosion and deep scratches.
- (4) Inspect all threaded piping components (figure 4-18) for cracks and stripped or damaged threads.
- (5) Inspect frame (10, figure 4-17) for cracks, broken welds and bent frame components.

- d.
- Repair.
- Replace damaged parts and all sealing components. Do not reuse diaphragm (10, figure 4-19), disc (12) or packing (17).

e. Assembly

Assemble Pressure Regulating Valve. Refer to figure 4-20.

NOTE

Ensure that anti-seize tape is applied in the same direction as the threads.

- (1) Apply anti-seize tape to threads of plugs (1, 18, and 19).
- (2) Install two plugs (19) in body (20).
- (3) Install plugs (1 and 18) in cover (4).
- (4) If removed, install packing (17) and seat (16) in body (20).
- (5) Install disc guide (14) and spacer washer (13) on stem (15).

NOTE

Number of spacer washers must be adjusted during assembly to prevent over compression of disc.

- (6) Position disc (12) on disc retainer (11), then slide both parts onto stem (15).

4-27. PRESSURE REGULATING VALVE REPAIR - cont.

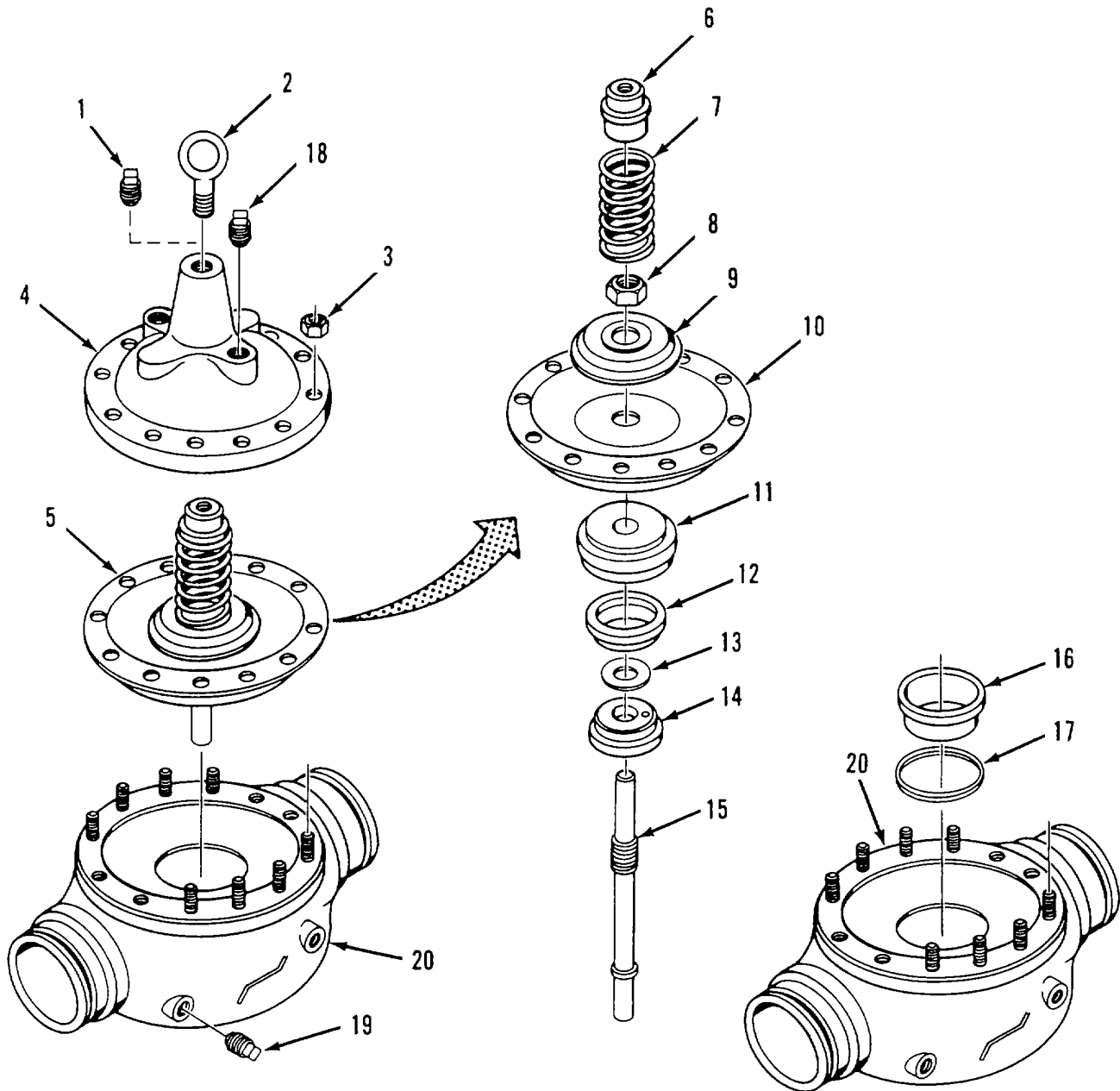

Figure 4-20. Pressure Regulating Valve Assembly.

4-27. PRESSURE REGULATING VALVE REPAIR - cont.**CAUTION**

To prevent premature failure of diaphragm, nut must be tight. If nut is loose on stem, diaphragm could pull loose and tear under pressure.

- (7) Install diaphragm (10), diaphragm washer (9) and nut (8) on stem (15). Tighten nut until diaphragm cannot be twisted on stem.
- (8) Check compression of disc (12) between disc guide (14) and disc retainer (11). Disc should be compressed very lightly. If disc is deformed, install additional spacer washers (13) between disc guide and disc retainer as required.

CAUTION

To prevent damage to stem or seat, lower stem straight into seat (16).

- (9) Lower assembled diaphragm (5) into body (20). Make sure end of stem (15) mates correctly with seat (16).
- (10) Align holes in diaphragm (10) with studs on body (20). If required, diaphragm may be stretched to fit over studs.
- (11) If removed, install bearing (6) in cover (4).
- (12) Install spring (7) on stem (15).
- (13) If removed, install cover bearing (6) in cover (4).

CAUTION

To prevent damage to bearing cover or valve stem, cover must be lowered straight onto stem without twisting or binding.

- (14) While matching alignment marks made during disassembly, lower cover (4) over stem (15) and onto valve body (20).
- (15) Install eight nuts (1) on cover (4) until handtight.

Assemble Bypass Piping. Refer to figure 4-21.

NOTE

Ensure that anti-seize tape is applied in the same direction as the threads.

- (16) Apply anti-seize tape to male threads of nipples (5, 7, 12, 14, 16, 18 and 22), elbows (9 and 20), bushings (19 and 23), connector (3) and restrictor (10).
- (17) Screw bushing (23) and 1-inch nipple (22) onto pressure regulating valve (24).

4-27. PRESSURE REGULATING VALVE REPAIR - cont.

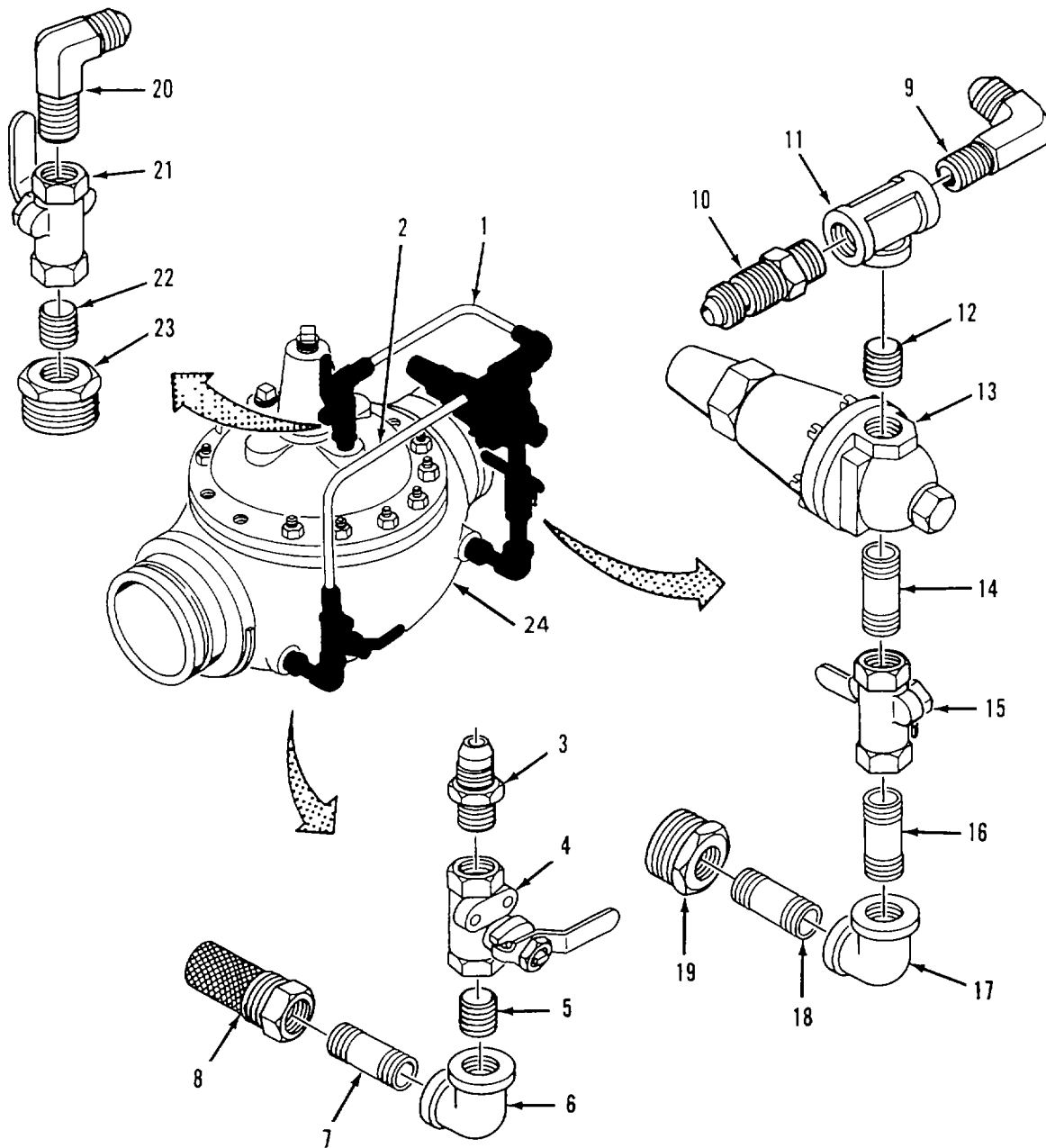

Figure 4-21. Pressure Regulating Valve Piping Installation.

4-27. PRESSURE REGULATING VALVE REPAIR - cont.

(18) Screw valve (21) onto 1-inch nipple (22). Make sure valve is positioned so that handle is pointing up when valve is open.

(19) Screw elbow (20) onto valve (21). Elbow must be positioned to allow connection of line (1).

Assemble Outlet Piping. Refer to figure 4-21.

(20) Screw bushing (19), 1½ inch nipple (18) and elbow (17) into pressure regulating valve (24).

(21) Screw 2 ½-inch nipple (16) and valve (15) onto elbow (17). Position valve so that handle is pointing up when valve is open. Make sure handle will not hit side of pressure regulating valve (24) when handle is operated.

(22) Screw 3-inch nipple (14) and regulating valve (13) onto valve (15). Regulating valve must be positioned as shown.

(23) Screw 1-inch nipple (12) and tee (11) onto regulating valve (13).

(24) Screw elbow (9) and restrictor (10) onto tee (11)

(25) Position line (1) between elbow (9) and elbow (20) Adjust position of elbows as required, then connect both ends of line to elbows.

Assemble Inlet Piping. Refer to figure 4-21.

(26) Screw 1-inch nipple (5), elbow (6), 2-inch nipple (7) and strainer (8) into pressure regulating valve (24)

(27) Screw valve (4) onto 1-inch nipple (5) Position valve so that handle is pointing up when valve is open Make sure handle will not hit side of pressure regulating valve (24) when handle is operated

(28) Screw connector (3) onto valve (4).

(29) Connect line (2) between connector (3) and restrictor (10).

Install Valve. Refer to figure 4-22.

NOTES

- Pressure regulating valve must be repositioned during installation to clear sides of frame.
- Make sure body of pressure regulating valve is seated in saddles of frame.

(30) Using lifting device, carefully lower pressure regulating valve (9) into frame (10). Turn valve as required to clear sides of frame.

4-27. PRESSURE REGULATING VALVE REPAIR - cont.

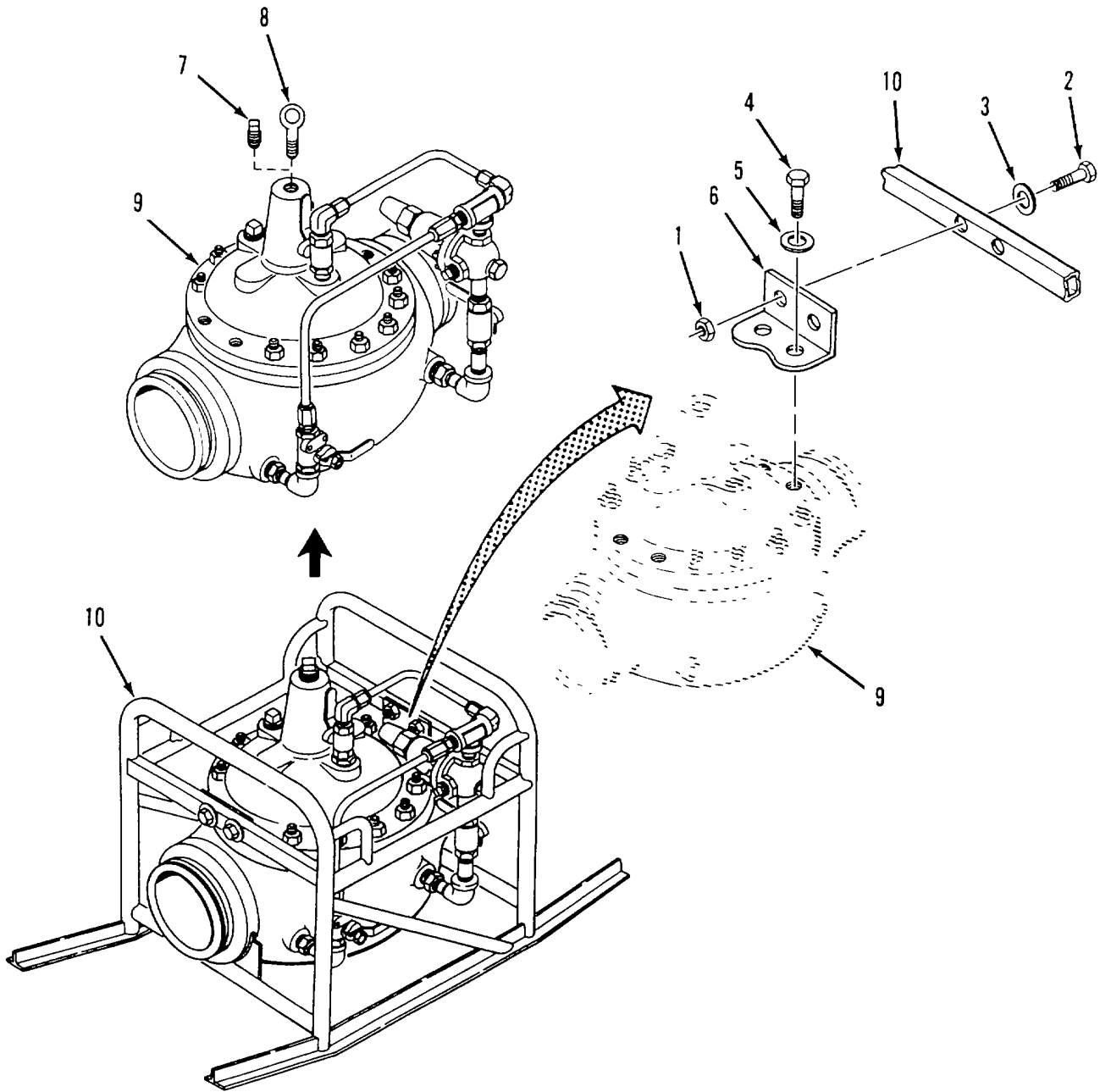

Figure 4-22. Pressure Regulating Valve Installation.

4-27. PRESSURE REGULATING VALVE REPAIR - cont.

- (31) Position bracket (6) on top of pressure regulating valve (9) as shown.
- (32) Install bracket (6), two flat washers (5) and bolts (4) into top of pressure regulating valve (9).
- (33) Install two flat washers (3), bolts (2) and nuts (1) through frame (10) and bracket (6).
- (34) Repeat steps (1) and (2) for bracket (6) on other side of pressure regulating valve (9).
- (35) Tighten eight nuts (3, figure 4-19) on cover. Tighten nuts evenly in a cross pattern.
- (36) Remove eyebolt (8, figure 4-22) from top of pressure regulating valve (9) and install plug (7).
- (37) Install pressure regulating valve in water system (para 3-4).
- (38) Startup water system (para 2-13c) and check pressure regulating valve for leaks.

4-28. SUCTION HOSE (6-INCH) REPAIR.

For repair of the 6-inch suction hose, refer to para 4-17.

4-29. Y-CONNECTOR REPAIR.

This task consist of:

- | | | |
|---|--|---|
| <ul style="list-style-type: none"> a. Disassembly d. Repair | <ul style="list-style-type: none"> b. Cleaning e. Assembly | <ul style="list-style-type: none"> c. Inspection |
|---|--|---|
-

INITIAL SETUP:

Tools:

- General Mechanics Tool Kit (Item 1, App B)
- Pipe Wrench (Item 2, App B)
- Vice (Item 2, App B)

Equipment Condition:

- Y-connector removed (para 3-4a)

Material/Parts:

- Detergent, General Purpose (Item 1, App E)
- Wiping Rag (Item 2, App E)
- Lubricant (Item 3, App E)
- Tape, Anti-seize (Item 4, App E)
- Gasket, Coupling Clamp (2) (Item 3, App I)
- Gasket, Coupling Clamp (Item 5, App I)
- Gasket (2) (Item 1, App I)

NOTES

- Ensure that all parts identified as mandatory replacement parts are discarded and replaced with new components.
- To remove and install coupling clamps, refer to para 2-11.

4-29. Y-CONNECTOR REPAIR - cont.

a. Disassembly. Refer to figure 4-23.

(1) Remove coupling clamp (1) and separate reducer assembly (2) from y fitting (7).

(2) Remove coupling clamp (3) and separate reducer assembly (4) from y fitting (7).

(3) Remove coupling clamp (5) and separate nipple assembly (6) from y fitting (7).

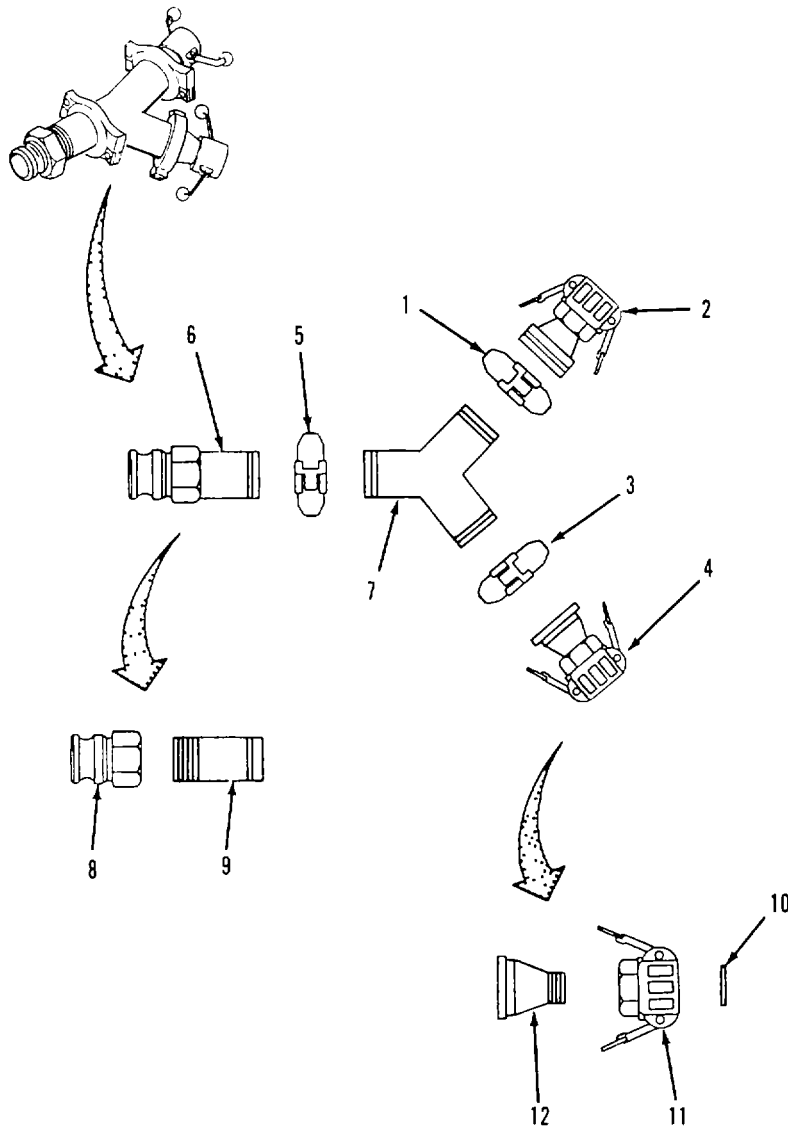

Figure 4-23. Y-Connector Disassembly.

4-29. Y-CONNECTOR REPAIR - cont.

- (4) Disassemble reducer assemblies (2) and (4) as follows:
 - (a) Remove gasket (10) from female coupling (11).
 - (b) Using pipe wrench and vice, unscrew female coupling (11) from reducer (12).
- (5) Using pipe wrench and vice, unscrew male coupling (8) from nipple (9).
- b. Cleaning.
 - (1) Wash all components with clean water and detergent.
 - (2) Rinse components in clean water and dry with wiping rag.
- c. Inspection.
 - (1) Inspect male coupling (8), female couplings (11), nipple (9) and yfitting (7) for cracks and corrosion.
 - (2) Inspect nipple (9), male coupling (8) and reducers (12) for damaged threads.
 - (3) Inspect nipple (9), y fitting (7) and reducers (12) for damaged coupling clamp sealing surfaces.
- d. Repair. Replace damaged parts and all sealing components.
- e. Assembly. Refer to figure 4-24.

NOTE

Ensure that anti-seize tape is applied in the same direction as the threads.

- (1) Apply anti-seize tape to male threads of nipple (9) Screw male coupling (8) onto nipple (9).
- (2) Assemble reducer assemblies (2) and (4) as follows:

NOTE

Ensure that anti-seize tape is applied in the same direction as the threads.

- (a) Apply anti-seize tape to male threads of reducer (12). Screw female coupling (11) onto reducer (12).
- (b) Install gasket (10) in female coupling (11).
- (3) Align nipple assembly (6) with y fitting (7) and install coupling clamp (5).

4-29. Y-CONNECTOR REPAIR - cont.

- (4) Align reducer assembly (4) with y fitting (7) and install coupling clamp (3).
- (5) Align reducer assembly (2) with y fitting (7) and install coupling clamp (1).
- (6) Install Y-connector in water system (para 3-4).
- (7) Startup water system (para 2-13c) and check Y-connector for leaks.

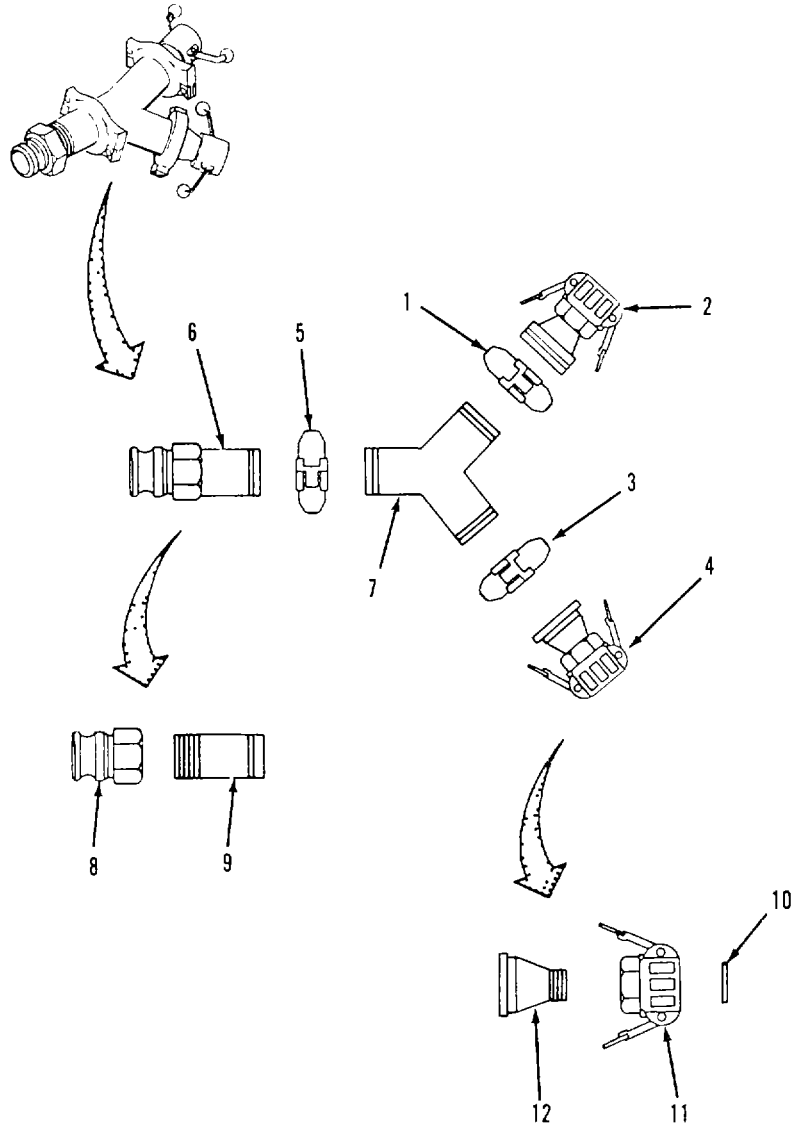

Figure 4-24. Y-Connector Assembly.

4-30. PUMPING STATION MAINTENANCE.

The pumping station consists of the components listed below. Refer to the following paragraphs for applicable maintenance procedures.

Procedure	Para.
Discharge Hose Assembly Repair.....	4-17
Butterfly Valve Repair	4-31

4-31. BUTTERFLY VALVE REPAIR.

This task consist of:

- | | | |
|--|---|-----------------------------|
| <p>a. Disassembly</p> <p>d. Repair</p> | <p>b. Cleaning</p> <p>e. Assembly</p> | <p>c. Inspection</p> |
|--|---|-----------------------------|
-

INITIAL SETUP:

Tools:

General Mechanics Tool Kit (Item 1, App B)

Equipment Condition:

Butterfly valve removed (para 3-6a)

Material/Parts:

Detergent, General Purpose (Item 1, App E)

Wiping Rag (Item 2, App E)

Lubricant (Item 3, App E)

Coupling Gasket (Item 3, App I)

Packing (Item 9, App I)

- a. Disassembly. Refer to figure 4-25.
 - (1) Remove two nuts (1) and bolts (2).
 - (2) Separate upper housing (3) from barrel assembly (7).
 - (3) Remove packing (4) from drive shaft (9).
 - (4) Separate lower housing (5) from barrel assembly (7).
 - (5) Remove packing (6) from shaft (8).

- b. Cleaning.
 - (1) Wash all components with clean water and detergent.
 - (2) Rinse components in clean water and dry with wiping rag.

- c. Inspection.
 - (1) Inspect upper housing (3) for cracks, corrosion, and stuck or binding handwheel.
 - (2) Inspect lower housing (5) for cracks and corrosion.
 - (3) Inspect barrel assembly (7) body for cracks and corrosion.

4-31. BUTTERFLY VALVE REPAIR - cont.

(4) Inspect interior of barrel assembly (7) for torn seal (11) and damaged butterfly (10).

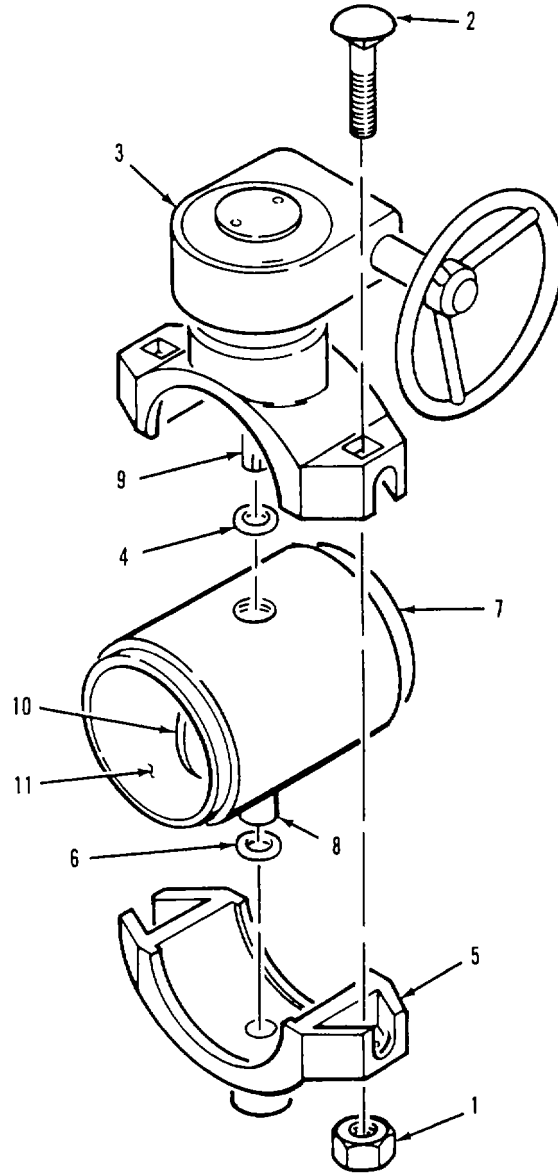

Figure 4-25. Butterfly Valve Disassembly.

4-31. BUTTERFLY VALVE REPAIR - cont.

- d. Repair Replace damaged parts and all sealing components.

NOTE

Barrel assembly, consisting of body, seal, butterfly and packings, must be replaced as one unit.

- e. Assembly. Refer to figure 4-26.

- (1) Apply lubricant to packing (6) Slide packing (6) onto shaft (8).
- (2) Apply lubricant to packing (4) Slide packing (4) onto drive shaft (9).
- (3) Position upper housing (3) onto barrel assembly (7) Rotate handle on upper housing as required to mate drive shaft (9) with butterfly (10).
- (4). Position lower housing (5) onto barrel assembly (7) Shaft (8) must align and mate with bearing in lower housing (5).
- (5) While holding upper housing (3) and lower housing (5) in place, install two bolts (2) and nuts (1). Tighten nuts evenly.
- (6) Turn handle on upper housing (3) and check for proper operation.
- (7) Install butterfly valve in water system (para 3-4).
- (8) Startup water system (para 2-13c) and check butterfly valve for leaks.

4-31. BUTTERFLY VALVE REPAIR - cont.

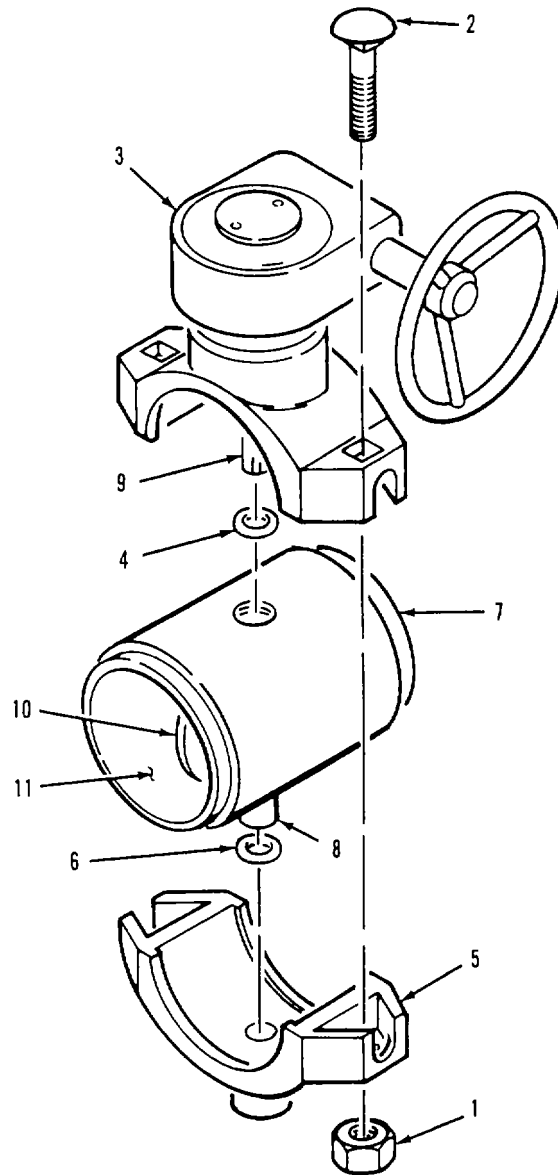

Figure 4-26. Butterfly Valve Assembly.

Section VI. PREPARATION FOR STORAGE OR SHIPMENT**4-32. SECURITY PROCEDURES.**

Refer to AR 190-11 or AR 190-13.

4-33. ADMINISTRATIVE STORAGE.

a. Placement of equipment in administrative storage should be for short periods of time when a shortage of maintenance effort exists. Items should be mission ready within 24 hours or within the time factors as determined by the directing authority. During the shortage period, appropriate maintenance records will be kept.

b. Before placing equipment in administrative storage, current maintenance services and equipment serviceable criteria (ESC) evaluations should be completed, shortcomings and deficiencies should be corrected, and all modification work orders (MWOs) should be applied.

c. Storage Site Selection Inside storage is preferred for items selected for administrative storage. If inside storage is not available, keep components away from corrosive materials, such as saltwater spray.

CHAPTER 5

DIRECT SUPPORT MAINTENANCE INSTRUCTIONS

Direct Support Maintenance Procedures 5-1
 5-1. Introduction..... 5-1
 5-2. Flaking Box Repair 5-1
 5-3. Pressure Regulating Valve Repair..... 5-3

DIRECT SUPPORT MAINTENANCE PROCEDURES

5-1. INTRODUCTION.

This Chapter contains instructions for performing Direct Support level maintenance on the Tactical Water Distribution System.

5-2. FLAKING BOX REPAIR.

This task consist of: a. Repair

INITIAL SETUP:

Tools:

Welding Shop (Appendix B, Sec III, Item 3)

References:

TM 9-237 Welding Theory and Application
 TM 43-0139 Painting Instructions for Army Materiel

Repair

- a. Inspect flaking box frame for cracked or broken welds and bent or smashed frame components.
- b. Weld flaking box frame as required in accordance with TM 9-237.
- c. Paint pressure flaking box frame in accordance with TM 43-0139.

5-2. PRESSURE REGULATING VALVE REPAIR.

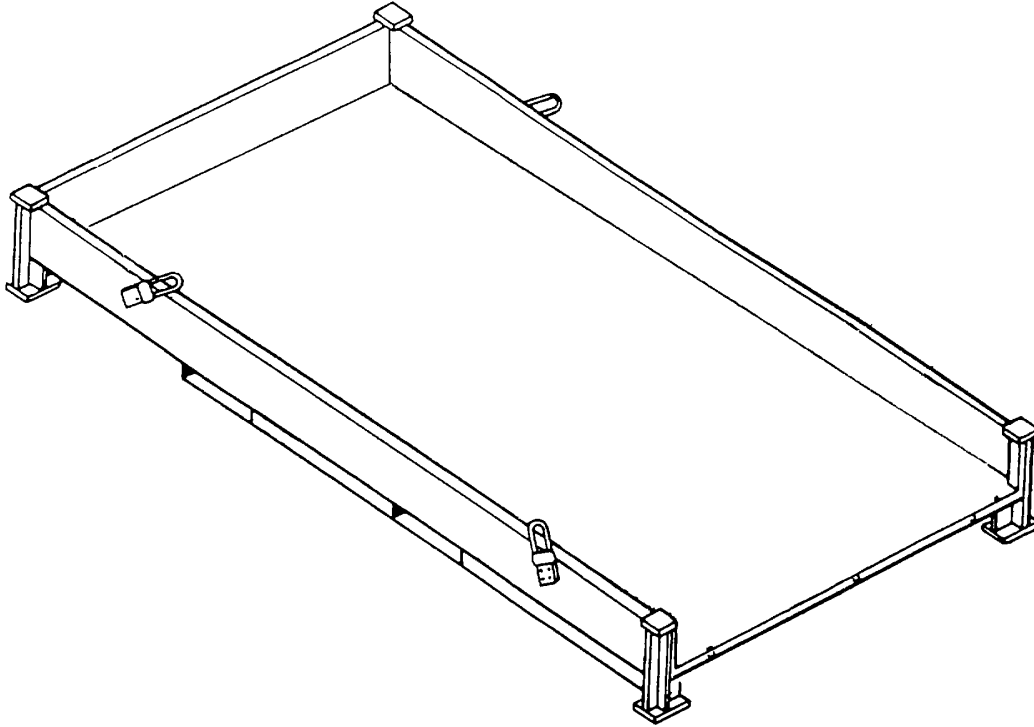

Figure 5-1. Flaking Box Frame.

5-3. PRESSURE REGULATING VALVE REPAIR.

This task consist of: a. Repair

INITIAL SETUP:

Tools:

Welding Shop (Appendix B, Sec III, Item 3)

References:

TM 9-237 Welding Theory and Application
TM 43-0139 Painting Instructions for Army
Materiel

Repair.

- a. Inspect pressure regulating valve frame for cracked or broken welds and bent or smashed frame components.
- b. Weld pressure regulating valve frame as required in accordance with TM 9-237.
- c. Paint pressure regulating valve frame in accordance with TM 43-0139.

5-2. PRESSURE REGULATING VALVE REPAIR.

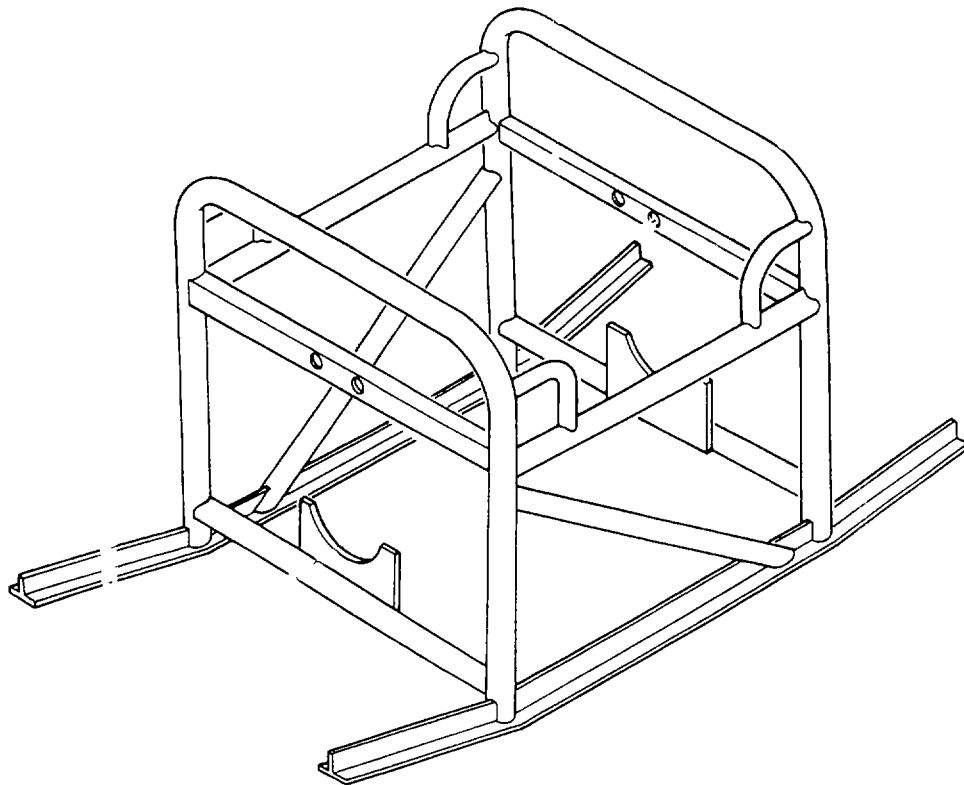

Figure 5-2. Pressure Regulating Valve Frame.

APPENDIX A

REFERENCES

A-1. SCOPE

This appendix lists all forms, field manuals, technical manuals, and miscellaneous publications referenced in this manual

A-2. FORMS

Equipment Control Record.....	DA Form 2408-9
Equipment Inspection and Maintenance Worksheet.....	DA Form 2404
Quality Deficiency Report.....	SF368
Recommended Changes to DA Publications.....	DA Form 2028-2
Recommended Changes to Publications and Blank Forms.....	DA Form 2028
Report of Discrepancy.....	SF 364

A-3. FIELD MANUALS

First Aid for Soldiers.....	FM 21-11
-----------------------------	----------

A-4. MISCELLANEOUS

Consolidated Index of Army Publications and Blank Forms.....	DA PAM 25-30
Destruction of Army Materiel to Prevent Enemy Use.....	TM 750-244-3
Painting Instructions for Army Materiel.....	TM 43-0139
The Army Maintenance Management System (TAMMS).....	DA PAM 738-750
Welding Theory and Application.....	TM 9-237
Operator's, Unit and Direct Support Maintenance Manual (Including Repair Parts and Special Tools List) for TRICON Multipurpose Equipment Shelter.....	TM 55-8145-200-13&P

**APPENDIX B
MAINTENANCE ALLOCATION CHART**

Section I. INTRODUCTION

B-1. GENERAL.

- a. This section provides a general explanation of all maintenance and repair function authorized at various maintenance categories.
- b. The Maintenance Allocation Chart (MAC) in Section II designates overall authority and responsibility for performance of maintenance functions on the identified end item or component. The application of the maintenance functions to the end item or component will be consistent with the capacities and capabilities of the designated maintenance categories.
- c. Section III lists the tools and test equipment (both special tools and common tool sets) required for each maintenance function as referenced from Section II.
- d. Section IV contains supplemental instructions and explanatory notes for a particular maintenance function.

B-2. MAINTENANCE FUNCTIONS.

Maintenance functions will be limited to and are defined as follows:

- a. Inspect. To determine the serviceability of an item by comparing its physical, mechanical, and/or electrical characteristics with established standards through examination (e g , by sight, sound, or feel).
- b. Test. To verify serviceability by measuring the mechanical, pneumatic, hydraulic, or electrical characteristics of an item and comparing those characteristics with prescribed standards.
- c. Service. Operations required periodically to keep an item in proper operating condition, i.e., to lean (includes decontaminate, when required), to preserve, to drain, to paint, or to replenish fuel, lubricants, chemical fluids, or gases.
- d. Adjust. To maintain or regulate, within prescribed limits, by bringing into proper or exact position, or by setting the operating characteristics to specified parameters.
- e. Align. To adjust specified variable elements of an item to bring about optimum performance.
- f. Calibrate. To determine and cause corrections to be made or to be adjusted on instruments or test, measuring, and diagnostic equipments used in precision measurement. Consists of comparisons of two instruments, one of which is a certified standard of known accuracy, to detect and adjust any discrepancy in the accuracy of the instrument being compared.

B-2. MAINTENANCE FUNCTIONS-cont

- g. Remove/Install. To remove and install the same item when required to perform service or other maintenance functions Install may be the act of emplacing, seating, or fixing into position a spare, repair part, or module (component or assembly) in a manner to allow the proper functioning of an equipment or system.
 - h. Replace. To remove an unserviceable item and install a serviceable counterpart in its place. "Replace" is authorized by the MAC and is shown as the 3rd position code of the SMR code.
 - i. Repair. The application of maintenance services, including fault location/troubleshooting, removal/installation, and disassembly/assembly procedures, and maintenance actions to identify troubles, and restore serviceability to an item by correcting specific damage, fault, malfunction, or failure in a part, subassembly, module (component or assembly) end item, or system.
 - j. Overhaul. That maintenance effort (service/action) prescribed to restore an item to a completely serviceable/operational condition as required by maintenance standards in appropriate technical publications (i.e., DMWR). Overhaul is normally the highest degree of maintenance performed by the Army Overhaul does not normally return an item to like new condition.
 - k. Rebuild. Consists of those services/actions necessary for the restoration of unserviceable equipment to a like new condition in accordance with original manufacturing standards. Rebuild is the highest degree of material maintenance applied to Army equipment the rebuild operation includes the act of returning to zero those age measurements (hours/miles, etc.) considered in classifying Army equipment/components.
-

B-3. EXPLANATION OF COLUMNS IN THE MAC-SECTION II.

- a. Column 1, Group Number. Column 1 lists functional group code numbers, the purpose of which is to identify maintenance significant components, assemblies, subassemblies, and modules with the next higher assembly. End item group numbers are "00".
- b. Column 2, Component/Assembly. Column 2 contains the names of components, assemblies, subassemblies, and modules for which maintenance is authorized.
- c. Column 3, Maintenance Function. Column 3 lists the functions to be performed on the item listed in Column 2 (for a detailed explanation of these functions, see paragraph 13-2).
- d. Column 4, Maintenance Level. Column 4 specifies, by the listing of a work time figure (expressed as man-hours shown as whole hours or decimals) in the appropriate subcolumn(s), the level of maintenance authorized to perform the function listed in Column (3). This figure represents the active time required to perform that maintenance function at the indicated level of maintenance If the number or the complexity of the tasks within the listed maintenance function vary alt different maintenance levels, appropriate work time figures will be shown for each level. The work time figure represents the average time required to restore an item (assembly, subassembly, component, module, end item, or system) to a serviceable condition under typical field operating conditions. This time includes preparation item including any necessary disassembly/assembly time), troubleshooting/fault location time, and quality assurance/quality control time in addition to the

time required to perform the specific tasks identified for the maintenance functions authorized in the maintenance allocation chart. The system designations for the various maintenance levels are shown on the following page.

- C Operator or crew
- O Unit Maintenance
- F Direct Support Maintenance
- H General Support Maintenance
- D Depot Maintenance

- e. Column 5, Tools and Equipment. Column 5 specifies, by code, those common tool sets (not individual tools) common TMDE, and special tools, special TMDE, and support equipment required to perform the designated function.
- f. Column 6, Remarks. This column, when applicable, contains a letter code, in alphabetic order, which is keyed to the remarks contained in Section IV.

B-4. EXPLANATION OF COLUMNS IN TOOL AND TEST EQUIPMENT REQUIREMENTS, SECTION III.

- a. Column 1, Reference Code. The tool and test equipment reference code correlates with a code used in the MAC, Section II, Column 5.
- b. Column 2, Maintenance Level. The lowest category of maintenance authorized to use the tool or test equipment.
- c. Column 3, Nomenclature. Name or identification of the tool or test equipment.
- d. Column 4, National Stock Number. The national stock number of the tool or test equipment.
- e. Column 5, Tool Number. The manufacturer's part number.

B-5. EXPLANATION OF COLUMNS IN REMARKS, SECTION IV.

- a. Column 1, Reference Code. The code recorded in column 6, Section II.
- b. Column 2, Remarks. This column lists information pertinent to the maintenance function being performed as indicated in the MAC, Section II.

SECTION II MAINTENANCE ALLOCATION CHART								
(1) GROUP NUMBER	(2) COMPONENT/ASSEMBLY	(3) MAINTENANCE FUNCTION	(4) MAINTENANCE LEVEL				(5) TOOLS & EQPT	(6) REMARKS
			UNIT		DS	GS		
			C	O	F	H		
00	TACTICAL WATER DISTRIBUTION SYSTEM							
01	<u>Distribution Point</u>							
0101	Elbow Valve	Inspect Replace Repair	0.1 0.2 0.2	0.5			1	A
0102	Gate Valve, 2-inch	Inspect Replace Repair	0.1 0.2 0.2	1.5			1,2	A
0103	Distribution Nozzle, 1-1/2-inch	Inspect Replace Repair	0.1 0.2 0.2	0.5			1,2	A
0104	Discharge Hose, 2 in. x 20 ft.	Inspect Replace Repair	0.1 0.2 0.2	1.0			1,2,4	A
0105	Water Meter	Inspect Replace Repair	0.1 0.2 0.2	1.0			1	A
0106	Hypochlorination Unit							
0107	Discharge Hose, 2 in. x 10 ft.	Inspect Replace Repair	0.1 0.2 0.2	1.0			1,2,4	A
0108	Pump Assembly, 125 GPM							
0109	Suction Hose, 2-in x 20 ft.	Inspect Replace Repair	0.1 0.2 0.2	1.0			1,2,4	A
0110	Nozzle Stand Assembly	Inspect Replace Repair	0.1 0.2	0.7			1	

SECTION II MAINTENANCE ALLOCATION CHART								
(1) GROUP NUMBER	(2) COMPONENT/ASSEMBLY	(3) MAINTENANCE FUNCTION	(4) MAINTENANCE LEVEL				(5) TOOLS & EQPT	(6) REMARKS
			UNIT		DS	GS		
			C	O	F	H		
02	<u>Storage Assembly</u>							
0201	Discharge Hose, 4 in. x 10 ft.	Inspect Replace Repair	0.1 0.2 0.2	1.0			1,2,4	A
0202	Gate Valve, 4-inch	Inspect Replace Repair	0.1 0.2 0.2	1.5			1	A
0203	Tank, Fabric, Collapsible, 20,000 Gallons		0.5					B
03	<u>Suspension Assembly</u>							
0301	Storage Chest	Inspect Replace Repair	0.1 0.2 1.5				1, 2	
04	<u>Sling Assembly</u>	Inspect Replace Repair	0.1 0.2	1.0			1	
05	<u>Flaking Box Assembly</u>							
0501	Flaking Box	Inspect Replace Repair	0.1 0.2	2.5	3.0		1, 2, 3	C
0502	Discharge Hose, 6 in. x 500.ft.	Inspect Replace Repair	0.1 0.2 1.0	1.0			1,2,4,5,6, 7	
06	<u>Pressure Relief Valve</u>	Inspect Replace	0.1 0.2				4, 5, 6, 7	
07	<u>Press Regulating Valve, Skid (Mtd</u>	Inspect Replace Repair	0.1 0.2 0.2	1.5	3.0		1,2,3,4,5, 6, 7	A.C,

SECTION II MAINTENANCE ALLOCATION CHART								
(1) GROUP NUMBER	(2) COMPONENT/ASSEMBLY	(3) MAINTENANCE FUNCTION	(4) MAINTENANCE LEVEL				(5) TOOLS & EQPT	(6) REMARKS
			UNIT		DS	GS		
			C	O	F	H		
08	Suction Hose, 6 in. X 10 ft.	Inspect	0.1				1,2,4,5,6, 7	A
		Replace	0.2					
		Repair	0.2	1.0				
09	<u>Y Connector</u>	Inspect	0.1				1,2,5,6,7	A
		Replace	0.2					
		Repair	0.2	07				
10	<u>Pumping Station</u>							
1001	Butterfly Valve	Inspect	0.1				1,5,6,7	A
		Replace	0.2					
		Repair	0.2	1.2				
1002	Discharge Hose, 6 in. x 50 ft.	Inspect	0.1				1,2,4,5,6, 7	A
		Replace	0.2					
		Repair	0.2	1.0				
1003	Discharge Hose, 6 in. x 10 ft.	Inspect	0.1				1,2,4,5,6, 7	A
		Replace	0.2					
		Repair	0.2	1.0				
1004	Discharge Hose, 6 in. x 20 ft.	Inspect	0.1				1,2,4,5,6, 7	A
		Replace	0.2					
		Repair	0.2	1.0				
1005	Pressure Relief Valve	Inspect	0.1				5, 6,7	A
		Replace	0.2					
		Repair	0.2					
1006	Check Valve	Inspect	0.1				5,6,7	A
		Replace	0.2					
		Repair	0.2					
1007	Pumping Assembly, 600 Gpm	Remove/Install	0.5				5,6, 7	B
11	<u>Tricon</u>							D
12	<u>Accessories</u>	Inspect	0.1					E
		Replace	0.1					

Section III. TOOLS AND TEST EQUIPMENT REQUIREMENTS.

(1) REFERENCE CODE	(2) MAINTENANCE CATEGORY	(3) NOMENCLATURE	(4) NATIONAL STOCK NUMBER (NSN)	(5) TOOL NUMBER
1	O	Tool Kit, General Mechanics	5180-00-177-7033	SC 5180-90-CL-N26
2	O	Shop Equipment, Automotive, Common No 1	4910-00-754-0654	SC-4910-95-CL-A74
3	F	Welding Shop, Trailer Mounted	3431-01-090-1231	SC3431-95-CL-A04
4	O	Clamping Tool	5120-00-278-9925	GGG-C-00413
5	C	Assembly Tool, Coupling Clamp		Style792 (79154)
6	C	Hammer, Hand, 16 Oz	5120-00-061 8543	
7	C	Punch, Drive Pin, 1/4 In	5120-00-240-6083	

Section IV. REMARKS

REFERENCE CODE	REMARKS
A	Crew repair limited to replacement of coupling gaskets.
B	Refer to applicable Technical Manual.
C	DS repair limited to welding and straightening of frame.
D	Refer to TM 55-8145-200-13&P.
E	Replace damaged, defective or missing components.

B-7/(B-8 blank)

APPENDIX C

COMPONENTS OF END ITEM AND BASIC ISSUE ITEMS LIST

Section I. INTRODUCTION**C-1. SCOPE.**

This appendix lists components of end item and basic issue items for the Tactical Water Distribution System to help you inventory items required for safe and efficient operation

C-2. GENERAL.

The Components of End Item and Basic Issue Items List are divided into the following sections:

- a. Section II Components of End Item. This listing is for informational purposes only, and is not authority to requisition replacements. These items are part of the end item, but are removed and separately packaged for transportation or shipment. As part of the end item, these items must be with the end item whenever it is issued or transferred between property accounts. Illustrations are furnished to assist you in identifying the items.
- b. Section III Basic Issue Items. These are the minimum essential items required to place the Tactical Water Distribution System in operation, to operate it, and to perform emergency repairs. Although shipped separately packaged, BII must be with the system during operation and whenever it is transferred between property accounts. The Illustrations will assist you with hard-to-identify items. This manual is your authority to request/requisition replacement BII, based on TOE/MTOE authorization of the end item.

C-3. EXPLANATION OF COLUMNS.

The following provides an explanation of columns found in the tabular listing:

- a. Column (1)-Illustration Number (Illus Number). This column indicates the number of the illustration in which the item is shown.
- b. Column (2)-National Stock Number. Indicates the national stock number assigned to the item and will be used for requisitioning purposes.
- c. Column (3)-Description. Indicates the Federal item and name and, if required, a minimum description to identify and locate the item. The last line for each Item indicates the CAGE (in parentheses) followed by the part number.
- d. Column (4)-Unit of Measure (U/M). Indicates the measure used in performing the actual operational/maintenance function. This measure is expressed by a two-character alphabetical abbreviation (e g, ea., in, pr)
- e. Column (5)-Quantity required (Qty reqd). Indicates the quantity of the item authorized to be used with/on the equipment.

Section II. COMPONENTS OF END ITEM

(1) ILLUS NUMBER	(2) NATIONAL STOCK NUMBER	(3) DESCRIPTION CAGE and Part Number Usable on Code	(4) U/M	(5) QTY. RQD
1		ASSEMBLY TOOL, COUPLING CLAMP (79154) STYLE792	EA	4
2		COUPLING CLAMP, BOLTLESS, PIPE (79154) 6 791-A	EA	15
3		CAP, ALUM, END (79154) 05289-ITN	EA	1
4	4730-00-088-9286	COUPLING; HALF, QUICK DISCONNECT (96906) MS27024-17	EA	1
5		COUPLING HALF, QUICK DISCONNECT (96906)) MS27024-19	EA	1
	3835-01-199-4014	DISPLACEMENT AND EVACUATION KIT (974031 13226E1577 CONSISTING OF	EA	2
6	3835 01-361-5682	RECEIVER ASSEMBLY, BALL (97403) 13226E1579	EA	1
7		BALL, DISPLACEMENT (90598) 25128-1	EA	2
8		CAP, ALUM, END (8T694) 05289-1TN	EA	24
9		EJECTOR ASSEMBLY (90598) 25100-100	EA	1
10		COUPLING CLAMP, PIPE (79154) 6-791-A	EA	8
11		INLET ASSEMBLY (90598) 13225E9198	EA	1
12		ASSEMBLY TOOL, CLAMP (79154) STYLE792	EA	1
13		STORAGE CHEST (90598) 25027-100	EA	1

Section II. COMPONENTS OF END ITEM

(1) ILLUS NUMBER	(2) NATIONAL STOCK NUMBER	(3) DESCRIPTION CAGE and Part Number	Usable on Code	(4) U/M	(5) QTY. RQD
		DISTRIBUTION POINT, (97403) 13225E9091 CONSISTING OF:		EA	2
14		VALVE ASSEMBLY, ELBOW (90598) 13225E19091-Y		EA	2
15		HOSE ASSEMBLY, DISCHARGE (2-IN X 20.FT (97403) 13225E9136-2		EA	7
16	4730-01-068-5070	WYE, QUICK DISCONNECT (97403) 13219E(477		EA	3
17		VALVE ASSEMBLY, GATE, 2-IN (90598) 13219E9091-YI		EA	2
18	4730-01-064-0560	REDUCER (96906) MS49000-17		EA	2
19		NOZZLE, ASSEMBLY, DISTRIBUTION (97403) 13225E9091-Y2		EA	2
20		METER ASSEMBLY, FLOW IND (97403) 13225E9177		EA	1
21	4610-00-269-0163	HYPOCHLORINATION UNIT (81349) MII-H-12732		EA	1
22	4730-01-186-0821	REDUCER, QUICK DISCONNECT (96906) MS49000-19		EA	2
23	4720-01-163-5088	HOSE ASSEMBLY, DISCHARGE (2 IN X 10 FT) (97403) 13225E9136 1		EA	1
24	4320-01-156 3873	PUMP, CENTRIFUGAL, 125GPM (81349) MIL-P-52109		EA	1
25		COUPLING HALF, QD, FEMALE (INSTALL, ON ITEM 21) (96906) MS27026 11		EA	1
26		COUPLING, HALF, QD, MALE (INSTALL ON ITEM 21) (96906) MS27022-11		EA	1
27	4720-01-163-4684	HOSE ASSEMBLY, SUCTION (2 IN X 20 FT) (97403) 13225E9135-2		EA	1

Section II. COMPONENTS OF END ITEM

(1) ILLUS NUMBER	(2) NATIONAL STOCK NUMBER	(3) DESCRIPTION CAGE and Part Number	Usable on Code	(4) U/M	(5) QTY. RQD
28	4730-00-951-3295	REDUCER, QUICK DISCONNECT (96906) MS49000-5		EA	2
29	4610-01-117-8271	BAG, WATER (97403) 13200E6480		EA	2
30	4730-00-951-3297	REDUCER, QUICK DISCONNECT (96906) MS49000-11		EA	2
31	4730-00-840 0797	COUPLING HALF, QUICK DISCONNECT (96906) MS27022-17		EA	1
32	4730-00-088-9286	COUPLING, QUICK DISCONNECT (96906) MS27024 17		EA	1
33		NIPPLE, PIPE, BRASS (90598) 25010-5		EA	1
34	4930-01-120-7426	STAND ASSY, NOZZLE (97403) 13225E9140		EA	2
		FLAKING BOX ASSY (90598) 25050-102 CONSISTING OF:		EA	64
35		BOX ASSY, FLAKING (90598) 25651-100		EA	1
36		COUPLING CLAMP (79154) 6-791-A		EA	2
37		HOSE ASSEMBLY, DISCHARGE 6-IN X 500 FT (90598) 25008-12/(81349) MIL-H-53027		EA	2
38	4720-01-163 4686	HOSE ASSEMBLY, SUCTION, 6-INCH X 10 FT (97403) 13225E9135-6		EA	12
	3835-01-199-4015	HOSELINE PACKING KIT (97403) 13226E1571 CONSISTING OF:		EA	1
39		HOIST (81349) MIL-H-904,STYLE 2, TYPE H, 3/4 TON, CL2		EA	1
40	4610-01-355-8567	BOARD ASSEMBLY, PULL (97403) 13226E1572		EA	1

Section II. COMPONENTS OF END ITEM

(1) ILLUS NUMBER	(2) NATIONAL STOCK NUMBER	(3) DESCRIPTION CAGE and Part Number	Usable on Code	(4) U/M	(5) QTY. RQD
41		CHEST, STORAGE (90598) 25027-101		EA	1
42	5310-00-768-0318	NUT, PLAIN (96906) MS51967-14		EA	2
43	5306 00-141-7179	BOLT, EYE (96906) MS27950-8		EA	1
44		LUBRICANT, GASKET (19853) RPLU24PT		CN	2
45	5315 00-198-5231	NAIL, (COMPOSITION, ROUND (96906) MS90714 8B		EA	240
46		NIPPLE, GROOVED TO THREADED PIPE (8T694) 05290-2TN		EA	1
		PUMPING STATION (97403) 13225E9088 CONSISTING OF:		EA	6
47		VALVE, BUTTERFLY (79154) V-060-700-0-EM		EA	3
48		HOSE ASSEMBLY, DISCHARGE, 6-IN X 50-FT (90598) 25008-104		EA	1
49		HOSE ASSEMBLY, DISCHARGE, 6-IN X 10-FT (90598) 25008-100		EA	1
50		HOSE ASSEMBLY, DISCHARGE, 6-IN X 20-FT (90598s) 25008-101		EA	1
51		VALVE, PRESSURE RELIEF (97403) 13225E9196		EA	1
52		VALVE, CHECK (79154) STYLE710X6		EA	1
53	4320-01-159-7992	PUMPING ASSEMBLY, 600 GPM (97403)) PD80366		EA	1
54		LATERAL, 45 DEG, GROOVED (79154) NO30X6		EA	2

Section II. COMPONENTS OF END ITEM

(1) ILLUS NUMBER	(2) NATIONAL STOCK NUMBER	(3) DESCRIPTION CAGE and Part Number Usable on Code	(4) U/M	(5) QTY. RQD
55		COUPLING, CLAMP (79154) 6-791-A	EA	8
56		ASSEMBLY TOOL, CLAMP (79154) STYLE792	EA	1
		REPAIR KIT, 6 INCH HOSELINE (97403) 13226E1581 CONSISTING OF:	EA	1
57		KNIFE, WOODHANDLE (29891) 60870	EA	2
58		CLAMP, HOSE (81349) MIL,-R-53013	EA	2
59		PLASTIC SHEET (81348) L-P-378 TY4CL2	RL	A/R
60		COUPLING CLAMP, PIPE (79154) 6-791 A	EA	3
61		ASSEMBLY TOOL, CLAMP (79154) STYL,E792	EA	1
62		SEAL, NONMETALLIC (79154) G-060-077-0-E0	EA	3
63		SEGMENT, CLAMP (79154) H-060-470-A-SM	EA	54
64		MENDER ASSEMBLY, HOSE (79154) STYLE4726IN	EA	6
65		NIPPLE ASSEMBLY, HOSE (79154) STYLE4716IN	EA	6
66		SOCKET (90598) 25043-7	EA	1
67		SOCKET (90598) 25043-8	EA	1
68		CHEST, STORAGE (90598) 25044-100	EA	1

Section II. COMPONENTS OF END ITEM

(1) ILLUS NUMBER	(2) NATIONAL STOCK NUMBER	(3) DESCRIPTION CAGE and Part Number	(4) Usable on U/M Code	(5) QTY. RQD
69	3835-01-187-1556	ROADWAY CROSSING GUARD (97403) 3226E1576	EA	24
70	3940-01-199-4010	SLING ASSEMBLY, FOUR LEG WITH SPREADER BAR (97403) 13226E1582	EA	1
		STORAGE ASSEMBLIES (97403) 13225E9089 CONSISTING OF	EA	2
71	4720-01-163-4682	HOSE ASSEMBLY, DISCHARGE, 4-IN X 10 FT (97403) 13225E9136-3	EA	4
72		VALVE ASSEMBLY, GATE, 4 IN (97403) 13225E9089-Y	EA	1
73		COUPLING ASSEMBLY (97403) 13225E9089-Y 1	EA	1
74		COUPLING CLAMP, PIPE (79154) 4-791 A	EA	1
75		TEE, REDUCING (79154) 6X6X425A	EA	1
76		COUPLING CLAMP, PIPE (79154) 6-791-A	EA	1
77		ASSEMBLY TOOL, CLAMP (79154) STYLE792	EA	1
78	5430-01-106-9678 OR 5430-01-351-7813	TANK, FABRIC COLLAPSIBLE (81349) MIL,-T-53029	EA	1
79	5430-01-168-0589	STORAGE CHEST, TANK (90598) 22000	EA	1
		SUSPENSION KIT, 6-INCH HOSELINE (90598) 25025-100 CONSISTING OF:	EA	5
80		ROPE, MANILA (90598) 25037-1-2	RL	2
81		SHACKLE, CHAIN (71747) 1/2TY1VCL2	EA	60

Section II. COMPONENTS OF END ITEM

(1) ILLUS NUMBER	(2) NATIONAL STOCK NUMBER	(3) DESCRIPTION CAGE and Part Number	Usable on Code	(4) U/M	(5) QTY. RQD
82		SADDLE, HOSE (97403) 13226E 1570		EA	60
83		TURNBUCKLE ASSEMBLY (90598) 25036 100		EA	4
84		CLAMP, WIRE ROPE (90598) 25025-3		EA	25
85		THIMBLE, ROPE (71747) 1/2 REGCLOSED		EA	4
86		ROPE, WIRE (39428) 3440T41		RL	1
87		BLOCK, TACKLE (39428) 3151T14		EA	4
88	4030-01-206-5035	STAKE, GUY (97403) 13225E9188		EA	14
89	3820-01-359-0869	DRIVE HEAD, STAKE (97403) 1325E9189		EA	1
90		HOIST, CHAIN (27353) LB020		EA	1
91		CHEST, STORAGE (90598) 25026-100		EA	1
92		SHELTER, NONEXPANDABLE (96906) MIL-S-28633		EA	4
93		SWIVEL JOINT, 6-INCH W/COUPLING (97403) 13225E9195		EA	64
94		VALVE ASSEMBLY, PRESSURE REGULATING, SKID MTD (86184) 61NCH90G-01ABKX		EA	1
95		VALVE ASSY, PRESSURE RELIEF (97403) 13225E9196		EA	1
96		WRENCH, SOCKET, ¾ DRIVE, 1.06 IN. (81348) GGG-W-641 TYPE II CLASS 2		EA	2
97		WRENCH, SOCKET, ¾ DRIVE, 1.25 IN (81348) GGG-W-641 TYPE II, CLASS 2		EA	4

Section II. COMPONENTS OF END ITEM

(1) ILLUS NUMBER	(2) NATIONAL STOCK NUMBER	(3) DESCRIPTION CAGE and Part Number	(4) Usable on U/M Code	(5) QTY. RQD
98		WRENCH, SOCKET, HANDLE, 3/4 DRIVE (81348) GGG-W-641, TYPE III, CLASS 2	EA	4
99		Y CONNECTION REDUCER (97403) 13225E9190	EA	1

Section II. COMPONENTS OF END ITEM-cont.

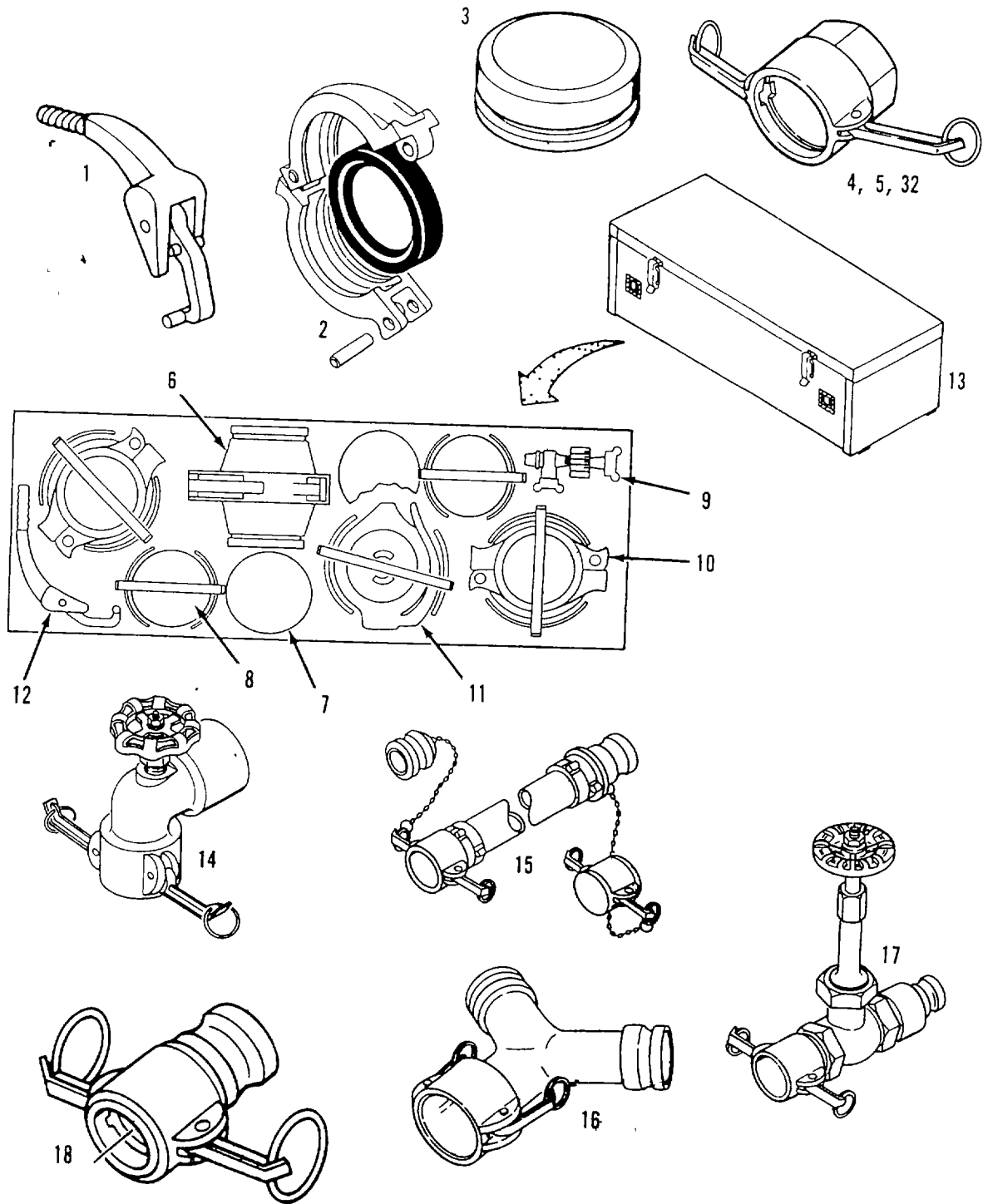

Section II. COMPONENTS OF END ITEM - cont.

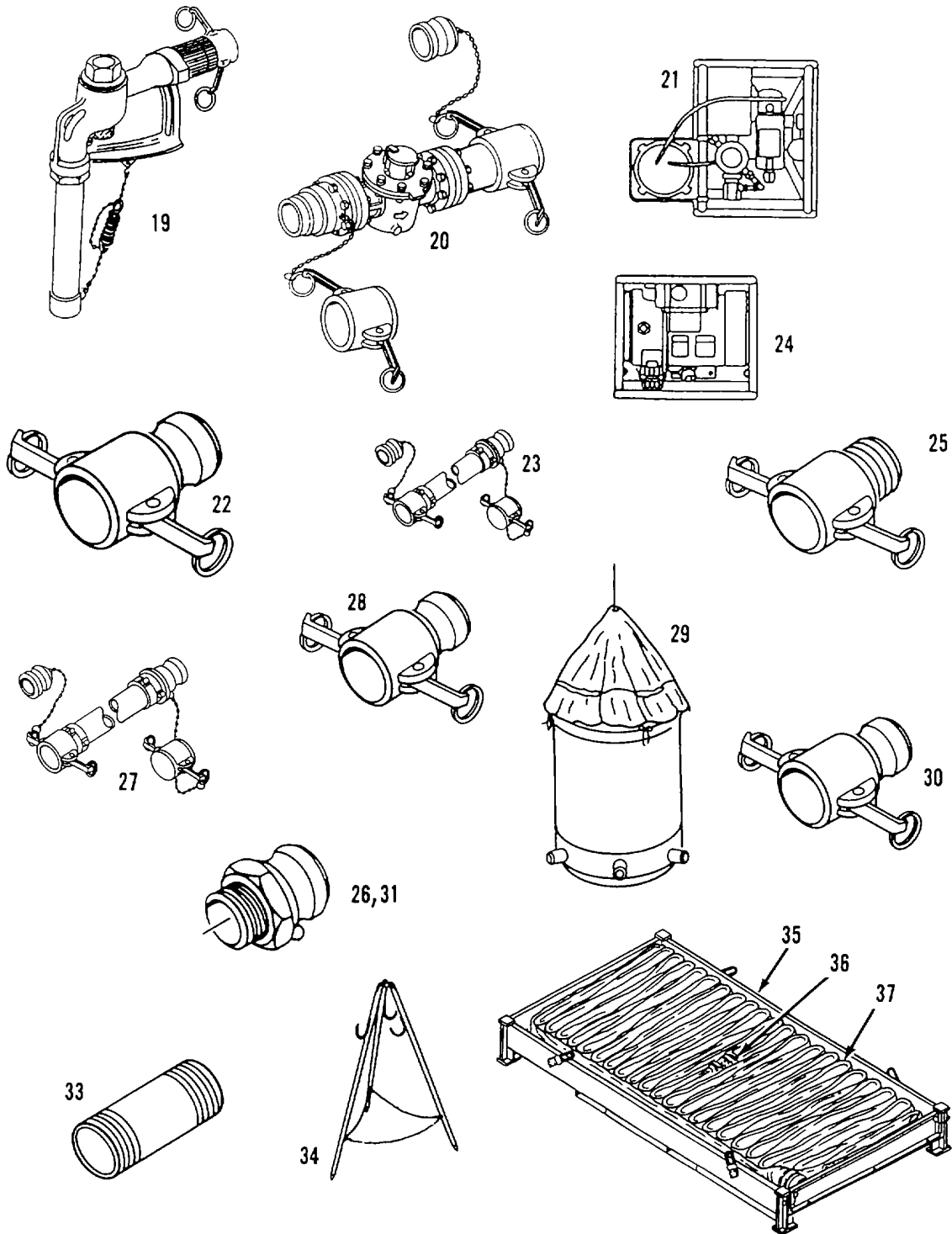

Section II. COMPONENTS OF END ITEM - cont.

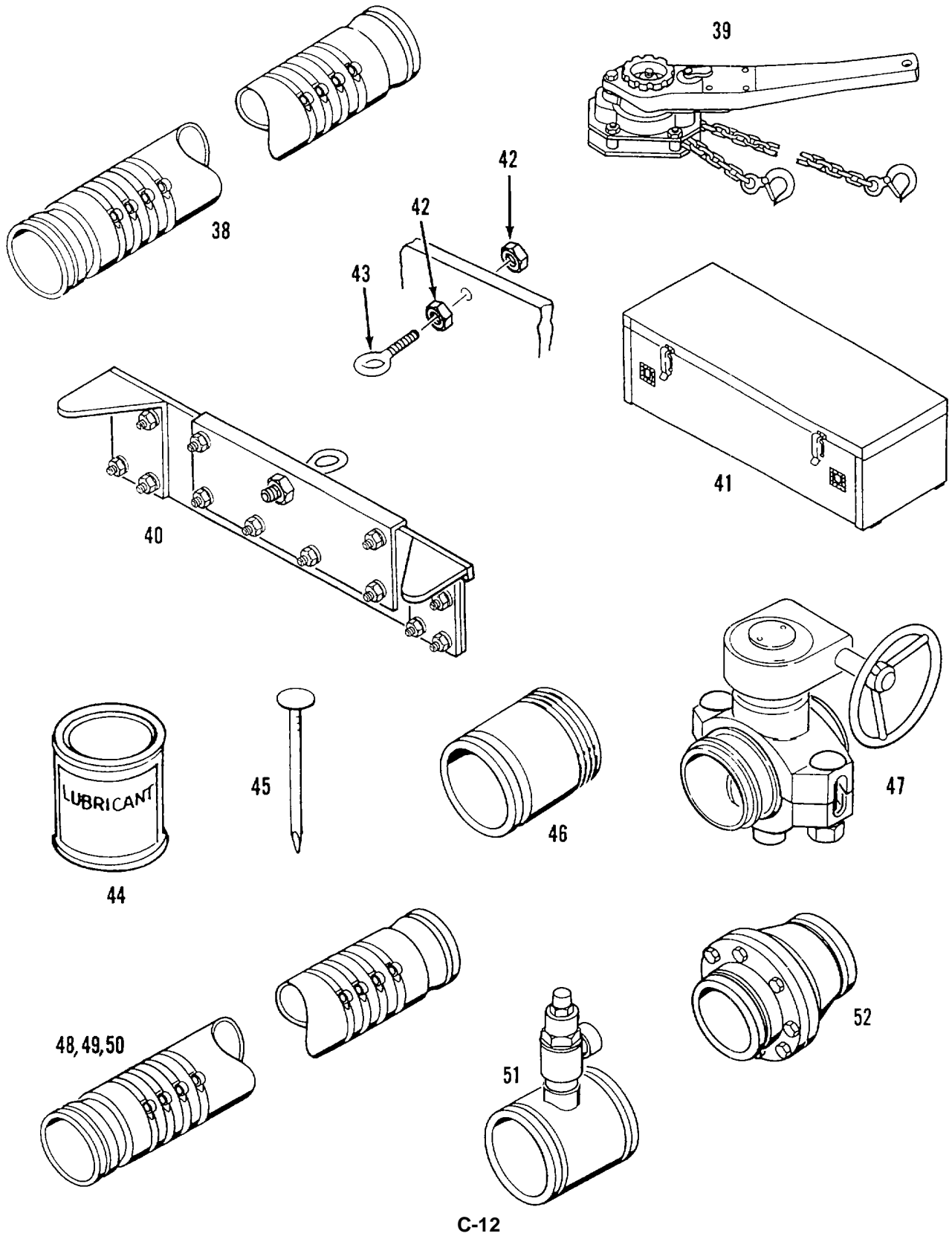

Section II. COMPONENTS OF END ITEM - cont.

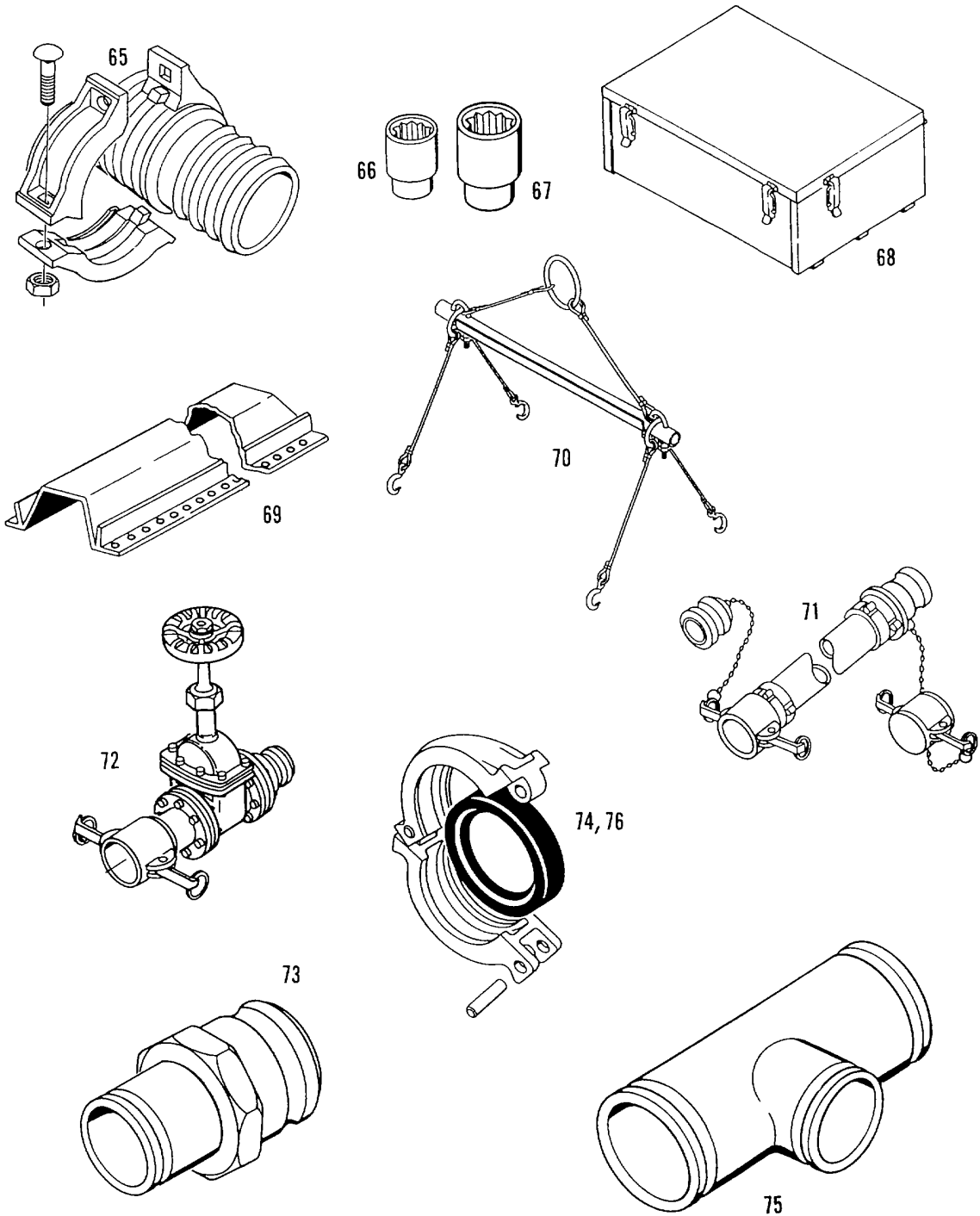

Section II. COMPONENTS OF END ITEM - cont.

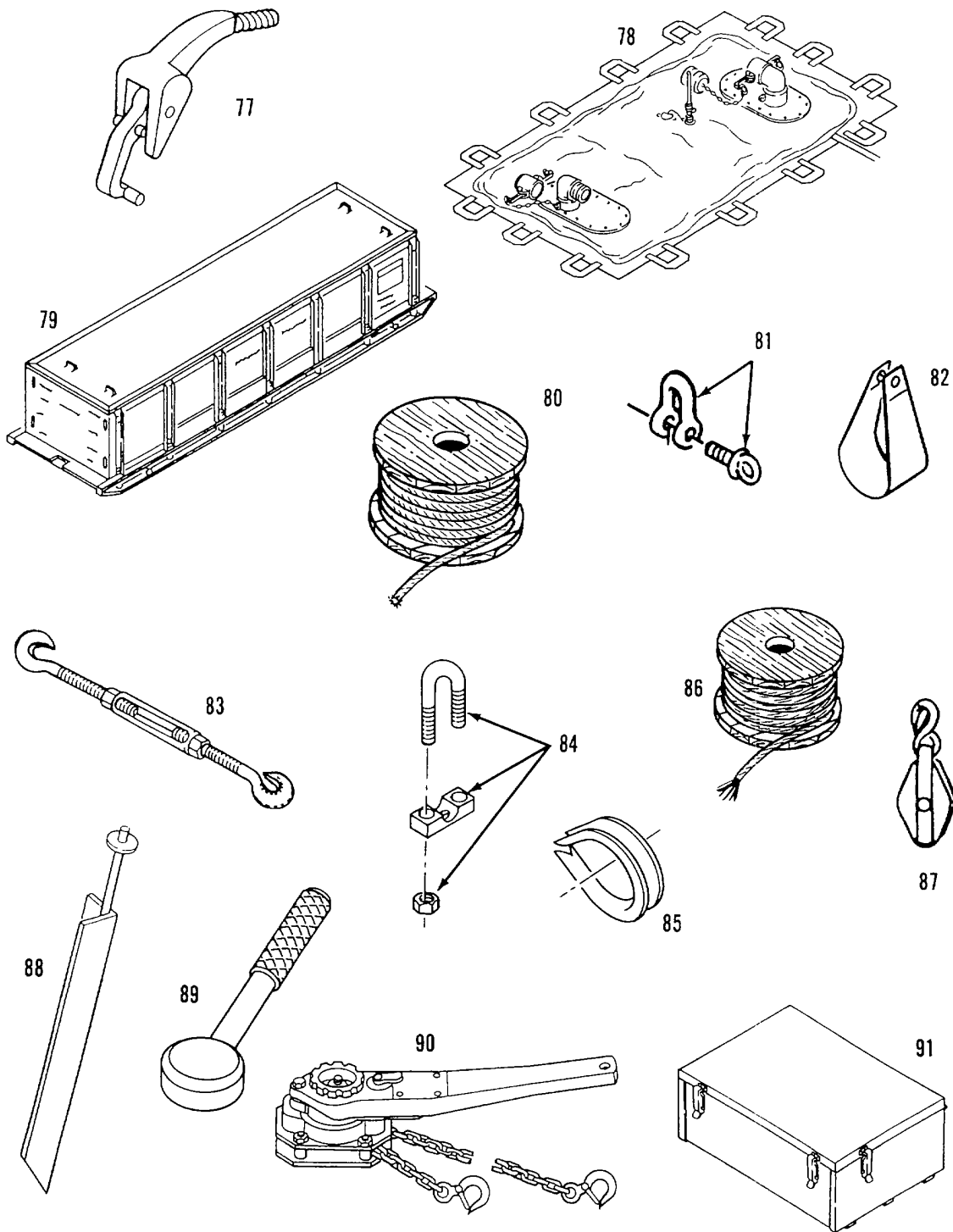

Section II. COMPONENTS OF END ITEM - cont.

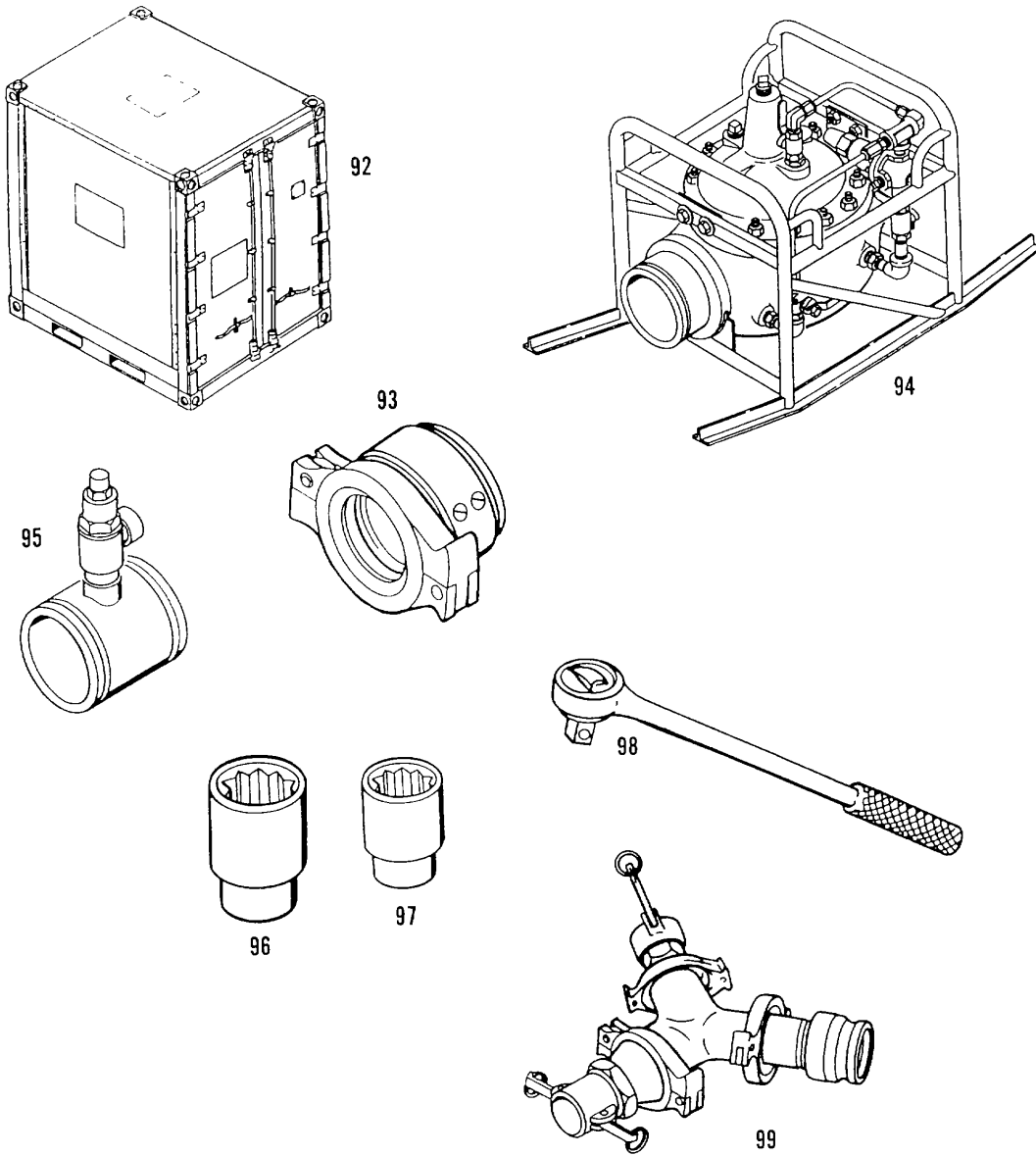

C-15

Section III. BASIC ISSUE ITEMS

(1) ILLUS NUMBER	(2) NATIONAL STOCK NUMBER	(3) DESCRIPTION CAGE and Part Number	Usable on Code	(4) U/M Code	(5) QTY. RQD
1		TECHNICAL MANUAL, OPERATOR'S, UNIT, DIRECT SUPPORT AND GENERAL SUPPORT MAINTENANCE MANUAL FOR TACTICAL, WATER DISTRIBUTION SYSTEM, TM 10-4320-345-14		EA	1
2	5120-00-061-8543	HAMMER, HAND, 16 OZ		EA	8
3	5120-00-240-6083	PUNCH, DRIVE PIN, 1/4 IN.		EA	8

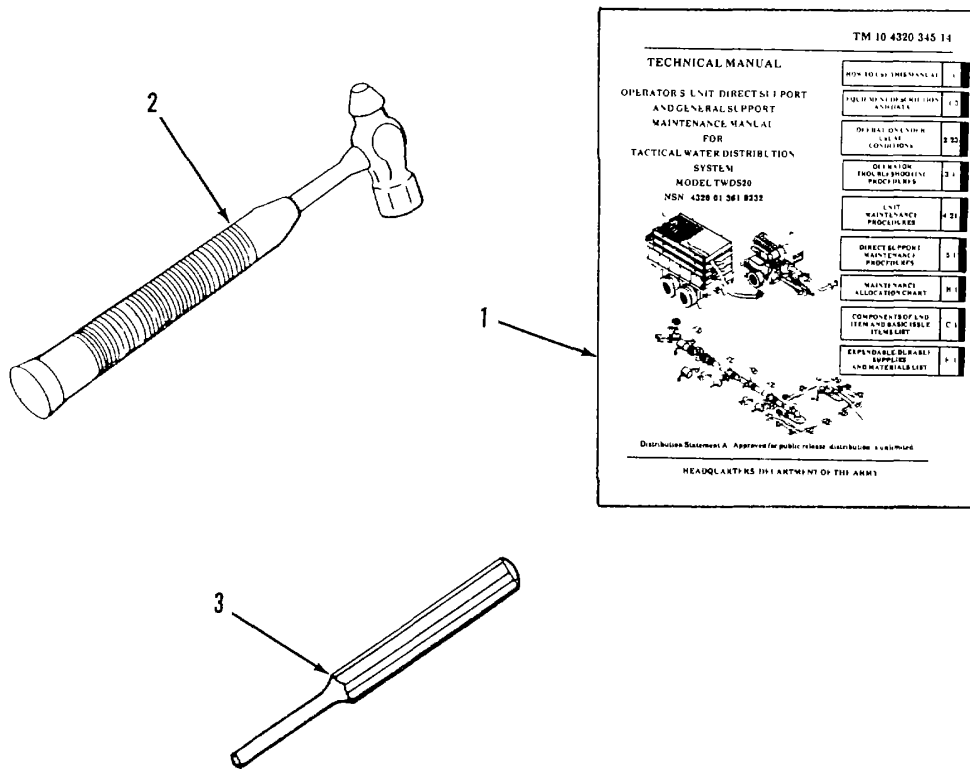

APPENDIX D

ADDITIONAL AUTHORIZATION LIST

Section I. INTRODUCTION

C-1. SCOPE.

This appendix lists additional items you are authorized for the support of the TWDS.

C-2. GENERAL.

This list identifies items that do not have to accompany the TWIS and that do not have to be turned in with it. These items are all authorized to you by CTA, MTOE, TDA, or JTA.

C-3. EXPLANATION OF LISTING.

Nation stock numbers, descriptions, and quantities are provided to help you identify and request the additional items you require to support this equipment. The items are listed in alphabetical sequence by item name. If the item you require differs between serial numbers of the same model, effective serial numbers are shown in the last line of the description. If item required differs for different models of this equipment, the model is shown under the "Usable on" heading in the description column.

Section II. ADDITIONAL AUTHORIZED ITEMS LIST

(1) NATIONAL STOCK NUMBER	(2) DESCRIPTION CAGEC & PART NUMBER USABLE ON CODE	(3) U/I	(4) QTY RECM
5805-00-543-0012	Telephone Set (80058) TA312/PT	EA	1
2320-01-047-8773	Truck, Cargo, 5-Ton, 6X6 LWB	EA	2

APPENDIX E

EXPENDABLE/DURABLE SUPPLIES AND MATERIALS LIST

Section I. INTRODUCTION

D-1. SCOPE.

This appendix lists expendable durable supplies and materials you will need to operate and maintain the Tactical Water Distribution System. This listing is for informational purpose only and is not authority to requisition the listed items. These items are authorized to you by CTA 50-970, Expendable/Durable Items (Except Medical, Class V, Repair Parts, and Heraldic Items), or CTA 8-100, Army Medical Department Expendable/Durable Items.

D-2. EXPLANATION OF COLUMNS.

- a. Column 1 Item Number. This number is assigned to the entry in the listing and is referenced in the task Initial Setup instructions to identify the material, e g, "Drycleaning solvent (App E)."
- b. Column 2 Category. This column identified the lowest category of maintenance that requires the listed item.

C - Operator/Crew
O - Unit Maintenance
F - Direct Support Maintenance
G - General Support Maintenance
- c. Column 3 National Stock Number. This is the national stock number assigned to the item, use it to request or requisition the items.
- d. Column 4 Description. Indicates the federal item name and, if required, a description to identify the item. The last line for each item indicates the part number followed by the Commercial And Government Entity (CAGE) Code for Manufacturer in parentheses, if applicable.
- e. Column 5 Unit of Measure (U/M). Indicates the measure used in performing the actual maintenance function. This measure is expressed by a two character alphabetical abbreviation (e g, ea, in, pr). If the unit of measure differs from the rest of the issue, requisition the lowest unit of issue that will satisfy your requirements.

Section II. EXPENDABLE/DURABLE SUPPLIES AND MATERIALS LIST

Item Number	Category	National Stock Number	Description	U/M
1	O	7930-00-985-6911	Detergent, General Purpose (81349) MIL-D-16791	GLI
2	O	7920-00-205-1711	Rags, wiping (58536) A-A-531	LB
3	O		Lubricant, Casket (19853) RPI,U24PT	CN
4	O	8030-00-889-3535	Tape, Anti-Seize (80244) MIL,-T-27730 SZ2	RL

APPENDIX F
LUBRICATION INSTRUCTIONS

NOT APPLICABLE

Refer to applicable TM for lubrication requirements on the 125 and 600 gpm pumps.











F-1/(F-2 Blank)

APPENDIX G
ILLUSTRATED LIST OF MANUFACTURED ITEMS

NOT APPLICABLE

G-1/(G-2 Blank)











**APPENDIX H
TORQUE LIMITS**

FASTENER	TYPE	MIN TENSILE STRNGN	MATERIAL	BODY SIZE OR OUTSIDE DIAMETER OF FASTENER															
				7/8	1	1 1/8	1 1/4	1 3/8	1 1/2	1 5/8	1 3/4	1 7/8	2	2 1/4	2 1/2	2 3/4	3		
	SAE 0-1-2	74 000 PSI	LOW CARBON STEEL	206	310	480	675	900	1100	1470	1900	2360	2750	3450	4400	7350	9500		
	SAE 3	100 000 PSI	MEDIUM CARBON STEEL	372	551	872	1211	1624	1943	2660	3463	4695	5427	7226	9049	13450	17548		
	SAE 5	120 000 PSI	MEDIUM CARBON HEAT TREAT STEEL	382	587	794	1105	1500	1775	2425	3150	4200	4550	6550	7175	13000	16000		
	SAE 6	133 000 PSI	MEDIUM CARBON STEEL QUENCHED TEMPERED	550	825	1304	1815	2434	2913	3985	5189	6980	7491	10825	14983	20151	26286		
	SAE 7	133 000 PSI	MEDIUM CARBON ALLOY STEEL	570	840	1325	1825	2500	3000	4000	5300	7000	7500	11000	15500	21000	27000		
	SAE 8	150 000 PSI	MEDIUM CARBON ALLOY STEEL	600	900	1430	1975	2650	3200	4400	5650	7600	8200	12000	17000	23000	29000		
	SOCKET HEAD CAP SCREW	160 000 PSI	HIGH CARBON CASE HARDENED STEEL	640	970	1520	2130	2850	3450	4700	6100	8200	8800	13000	18000	24000	31000		
	SOCKET SET SCREW	212 000 PSI	HIGH CARBON CASE HARDENED STEEL																
	MACHINE SCREW YELLOW BRASS	60 000 PSI	COPPER (CU) 63% ZINC (ZU) 37%	160	215	325	400		595										
	SILICONE BRONZE TYPE 'B'	70 000 PSI	COPPER (CU) 96% ZINC (ZN) 2% SILICON (SI) 2%	180	250	365	450		655										

There is no difference in the above chart between the torque figures for fine or coarse threads. The torque figures for a finely-threaded fastener as compared to a coarsely-threaded fastener of the same diameter may be slightly higher but hardly worth mentioning.

APPENDIX H

TORQUE LIMITS- cont.

FASTENER	TYPE	MIN TENSILE STRENGTH	MATERIAL	BODY SIZE OR OUTSIDE DIAMETER OF FASTENER																	
				2	3	4	5	6	8	10	1/4	1/10	1/8	1/16	1/2	5/16	3/8	3/4			
	SAE 0-1-2	74 000 PSI	LOW CARBON STEEL									6	12	20	32	47	68	96	155		
	SAE 3	100 000 PSI	MEDIUM CARBON STEEL									9	17	30	47	69	103	145	234		
	SAE 5	120 000 PSI	MEDIUM CARBON HEAT TREAT STEEL									10	19	33	54	78	114	154	257		
	SAE 6	133 000 PSI	MEDIUM CARBON STEEL QUENCHED TEMPERED									12.5	24	43	69	106	150	209	350		
	SAE 7	133 000 PSI	MEDIUM CARBON ALLOY STEEL									13	25	44	71	110	154	215	360		
	SAE 8	150 000 PSI	MEDIUM CARBON ALLOY STEEL									14	29	47	78	119	169	230	380		
	SOCKET HEAD CAP SCREW	180 000 PSI	HIGH CARBON CASE HARDENED STEEL	TORQUE VALUES All figures are foot-pounds except those marked with an asterisk (*), which are inch-pounds																	
	SOCKET SET SCREW	212 000 PSI	HIGH CARBON CASE HARDENED STEEL					9*	16*	30*	70*	140*	18	29	43	63	100	146			
	MACHINE SCREW YELLOW BRASS	60 000 PSI	COPPER (CU) 63% ZINC (ZU) 37%	2*	3.3*	4.4*	6.4*	8*	16*	20*	65*	110*	17	27	37	49	78	104			
	SILICONE BRONZE TYPE 'B'	70 000 PSI	COPPER (CU) 96% ZINC (ZNI) 2% SILICON (SI) 2%	2.3*	3.7*	4.9*	7.2*	10*	19*	22*	70*	125*	20	30	41	53	88	117			

There is no difference in the above chart between the torque figures for fine or coarse threads. The torque figures for a finely-threaded fastener as compared to a coarsely-threaded fastener of the same diameter may be slightly higher but hardly worth mentioning.

APPENDIX I

MADATORY REPLACEMENT PARTS

ITEM NO	NOMENCLATURE	PART NUMBER
1	Gasket (2-inch QI))	MS27030-6
2	Gasket (4-inch QI))	MS27030-9
3	Gasket, Coupling, 4-inch	G-040 075 0-E0
4	Pin, Coupling Clamp	7/16X2 YELLOW
5	Gasket, Coupling, 6-inch	G 040 077-0-E0
6	Pin, Coupling Clamp	1/2X21/16 GREEN
7	Packing (Stem)	BV1182-8
8	Packing	231AW-0219 2P
9	Disc	231A--0909 2D
10	Disc	231A--0913 2D
11	Seal	C254
12	Strapping	C204
13	Seal	C256
14	Strapping	C206
15	Clamp, 6 inch Hose Repair	L-290
16	Lockwasher	MS35338-46
17	Gasket, Flange (4-inch)	13220E1069-1
18	Packing (Water Meter)	411NT300C-13/P-6
19	Nut, Self Locking	MS51922-54
20	Cotter Pin	MS24665-134
21	Packing Ring	235RF-05082P
22	Gasket, Flange (Gate Valve)	235RF-05092G
23	Lockwasher	235RF-02212W
24	Rivet	SD64BS
25	Cotter Pin	MS24665-353
26	Diaphragm	80522G
27	Packing	00775H
28	Disc	V5564K

I-1/(I-2 Blank)

ALPHABETICAL INDEX

Paragraph	Page
-A-	
Administrative Storage	4-78
Assembly and Preparation for Use.....	2-23
-B-	
Butterfly Valve Repair.....	4-74
Butterfly Valves.....	2-4
-C-	
Checking Unpacked Equipment.....	4-3
Common Tools and Equipment.....	4-2
Component Replacement (Coupling Clamps).....	3-30
Component Replacement (Quick Disconnect Couplings).....	3-26
Corrosion Prevention and Control (CPC).....	1-1
Coupling Clamp Repair.....	3-34
-D-	
Decals and Instruction Plates.....	2-68
Decontamination.....	2-99
Destruction of Army Materiel to Prevent Enemy Use.....	1-2
Distribution Nozzle (1 1/2-Inch) Repair.....	4-28
Distribution Nozzles.....	2-3
Distribution Point Maintenance	4-21
-E-	
Elbow Valve Repair.....	4-22
Elbow Valves.....	2-5
Emergency Procedures.....	2-97
Equipment Characteristics and Features.....	1-3
Equipment Data.....	1-8
-F-	
Flaking Box Assembly Maintenance.....	4-56
Flaking Box Repair.....	4-56
-G-	
Gate Valve (2-inch) Repair.....	4-24
Gate Valve (4-inch) Repair.....	4-44
Gate Valves.....	2-2

ALPHABETICAL INDEX

Paragraph	Page
General	2-8, 4-21
Glossary	1-2
-H-	
Hose (6-inch) Repair.....	3-35
-I-	
Initial Adjustment	2-62
Introduction	5-1
Introduction	3-1
Introduction.....	4-4
-J-	
-K-	
-L-	
Leakage Definitions for Operator PMCS	2-9
List of Abbreviations.....	1-2
Location and Description of Major Components.....	1-4
-M-	
Maintenance Forms Records and Reports.....	1-1
Malfunction Index	3-2
Malfunction Index.....	4-4
-N-	
Nomenclature Cross Reference List.....	1-2
Nozzle Stand Repair.....	4-41
-O-	
Operating Auxiliary Equipment	2-68
Operating Procedures.....	2-63
Operation in Dusty or Sandy Areas.....	2-96
Operation in Extreme Cold (Below 0°F).....	2-94
Operation in Extreme Heat.....	2-96
Operation in Salt Water Areas.....	2-97
Operator Preventive Maintenance Checks and Services.....	2-11

-P-

ALPHABETICAL INDEX

Paragraph	Page
Personal Safety.....	4-21
PMCS Procedures.....	2-8
Preparation for Movement.....	2-69
Pressure Regulating Valve Repair	4-58
Pressure Regulating Valve Repair.....	5-1
Proper Equipment.....	4-21
Pumping Station Maintenance.....	4-64
Pumping Station Repair.....	4-74
-Q-	
Quick Disconnect Coupling Repair.....	3-28
-R-	
Repair Parts	4-2
Reporting of Equipment Improvement Recommendations (EIR)	1-2
-S-	
Scope.....	1-1
Security Procedures	4-78
Shelter Requirements.....	4-2
Siting	4-2
Sling Assembly Repair.....	4-54
Special Tools, TMDE and Support Equipment.....	4-2
Storage Assembly Maintenance.....	4-44
Storage Chest Repair.....	4-50
Suction and Discharge Hose Repair.....	4-33
Suction Hose Repair.....	4-70
Suspension Assembly Maintenance.....	4-49
System Technical Principles of Operation.....	1-9
-T-	
Troubleshooting.....	4-4
Troubleshooting Table.....	3-2
-U-	
-V-	
-W-	
Water Meter	2-6

ALPHABETICAL INDEX

Paragraph	Page
Water Meter Assembly Repair.....	4-38
Water Pressure Regulator.....	2-7
-X-	
-Y-	
Y-Connector Repair.....	4-70
-Z-	

By Order of the Secretary of the Army:

Official:

GORDON R. SULLIVAN
General, United States Army
Chief of Staff

MILTON H. HAMILTON
Administrative Assistant to the
Secretary of the Army
04286

DISTRIBUTION:

Limited distribution made to Activities who have this equipment.

☆U.S. GOVERNMENT PRINTING OFFICE: 1993-755-120/60508

RECOMMENDED CHANGES TO EQUIPMENT TECHNICAL PUBLICATIONS



THEN...JOT DOWN THE DOPE ABOUT IT ON THIS FORM. CAREFULLY TEAR IT OUT, FOLD IT AND DROP IT IN THE MAIL.

SOMETHING WRONG WITH PUBLICATION

FROM: (PRINT YOUR UNIT'S COMPLETE ADDRESS)

DATE SENT

PUBLICATION NUMBER

PUBLICATION DATE

PUBLICATION TITLE

BE EXACT PIN-POINT WHERE IT IS

PAGE NO.	PARA-GRAPH	FIGURE NO.	TABLE NO.

IN THIS SPACE, TELL WHAT IS WRONG AND WHAT SHOULD BE DONE ABOUT IT.

PRINTED NAME, GRADE OR TITLE AND TELEPHONE NUMBER

SIGN HERE

TEAR ALONG PERFORATED LINE

THE METRIC SYSTEM AND EQUIVALENTS

Linear Measure

1 centimeter = 10 millimeters = .39 inch
 1 decimeter = 10 centimeters = 3.94 inches
 1 meter = 10 decimeters = 39.37 inches
 1 dekameter = 10 meters = 32.8 feet
 1 hectometer = 10 dekameters = 328.08 feet
 1 kilometer = 10 hectometers = 3,280.8 feet

Weights

1 centigram = 10 milligrams = .15 grain
 1 decigram = 10 centigrams = 1.54 grains
 1 gram = 10 decigrams = .035 ounce
 1 dekagram = 10 grams = .35 ounce
 1 hectogram = 10 dekagrams = 3.52 ounces
 1 kilogram = 10 hectograms = 2.2 pounds
 1 quintal = 100 kilograms = 220.46 pounds
 1 metric ton = 10 quintals = 1.1 short tons

Cubic Measure

1 cu. centimeter = 1000 cu. millimeters = .06 cu. inch
 1 cu. decimeter = 1000 cu. centimeters = 61.02 cu. in.
 1 cu. meter = 1000 cu. decimeters = 35.31 cu. feet

Square measure

1 sq. centimeter = 100 sq. millimeters = .155 sq. in.
 1 sq. decimeter = 100 sq. centimeters = 15.5 inches
 1 sq. meter (centare) = 100 sq. decimeters = 10.76 feet
 1 sq. dekameter (are) = 100 sq. meters = 1,076.4 sq. ft.
 1 sq. hectometer (hectare) = 100 sq. dekameters = 2.47 acres
 1 sq. kilometer = 100 hectometers = .386 sq. miles

Liquid Measure

1 dekaliter = 10 liters = 2.64 gallons
 1 hectoliter = 10 dekaliters = 26.42 gallons
 1 kiloliter = 10 hectoliters = 264.18 gallons
 1 liter = 10 deciliters = 33.81 fl. ounces
 1 centiliter = 10 milliliters = .34 fl. ounce
 1 deciliter = 10 centiliters = 3.38 fl. ounces
 1 metric ton = 10 quintals = 1.1 short tons

Approximate Conversion Factors

To change	To	Multiply by	To change	To	Multiply by
inches	centimeters	2.540	ounce inches	newton-meters	.0070062
feet	meters	.305	centimeters	inches	.394
yards	meters	.914	meters	feet	3.280
miles	kilometers	1.609	meters	yards	1.094
sq. inches	sq. centimeters	6.451	kilometers	miles	.621
sq. feet	sq. meters	.093	sq. centimeters	sq. inches	.155
sq. yards	sq. meters	.836	sq. meters	sq. yards	10.764
sq. miles	sq. kilometers	2.590	sq. kilometers	sq. miles	1.196
acres	sq. hectometers	.405	sq. hectometers	acres	2.471
cubic feet	cubic meters	.028	cubic meters	cubic feet	35.315
cubic yards	cubic meters	.765	milliliters	fluid ounces	.034
fluid ounces	milliliters	29.573	liters	pints	2.113
pints	liters	.472	liters	quarts	1.057
quarts	liters	.946	grams	ounces	.035
gallons	liters	3.785	kilograms	pounds	2.205
ounces	grams	28.349	metric tons	short tons	1.102
pounds	kilograms	.454	pound-feet	newton-meters	1.356
short tons	metric tons	.907			
pound inches	newton-meters	.11296			

Temperature (Exact)

°F Fahrenheit temperature

5/9 (after subtracting 32)

Celsius Temperature °C

